

TM 11-6625-274-35

DEPARTMENT OF THE ARMY TECHNICAL MANUAL

FIELD AND DEPOT MAINTENANCE
MANUAL

TEST SETS, ELECTRON TUBE TV-7/U,
TV-7A/U, TV-7B/U, AND TV-7D/U

This reprint includes all changes in
effect at the time of publication:
Changes 4 and 5.

HEADQUARTERS, DEPARTMENT OF THE ARMY
30 JUNE 1960

WARNING

DANGEROUS VOLTAGES EXIST IN THIS EQUIPMENT

Be careful when working on the 330- and 154-volt ac power supply circuits, on the 115-volt ac line connections, and on terminal board E106. Serious injury or death may result from contact with these points.

DON'T TAKE CHANCES!

Changes in force: C 4 and C 5

TM 11-6625-274-35
C 5

CHANGE }
No. 5 }

HEADQUARTERS
DEPARTMENT OF THE ARMY
WASHINGTON, DC, 30 March 1976

**Direct Support, General Support, and Depot Maintenance Manual
TEST SETS, ELECTRON TUBE TV-7/U,
TV-7A/U, TV-7B/U, AND TV-7D/U**

TM 11-662527435, 30 June 1960, is changed as follows:

Pages, paragraph 1b lines 2 and 3. "TM 11-6625-274-12P and TM 11-6625-274-35P" is changed to read "TM 11-6625-274-25P."

Subparagraph c is superseded as follows:

c. You can help improve this manual by calling attention to errors and by recommending improvements and stating your reasons for the recommendations. Your letter or DA Form 2028 (Recommended Changes to Publications and Blank Forms) should be mailed direct to Commander, US Army Electronics Command, ATTN: DRSEL-MA-Q, Fort Monmouth, NJ 07703. A reply will be furnished direct to you.

Page 9, paragraph 7b(2), line 9. Change "121" to read "117."

Page 49, paragraph 36c, chart, performance standard column. Make the following changes:

Step 2b. Change "150 volts ± 3 " to read "150 volts ± 6 ."

Step 2d. Change "130 volts ± 3 " to read "130 volts ± 6 ."

Step 4, Performance standard column:

b(4). Change "0.65 to 0.72" to read "0.62 to 0.75."

c(4). Change "1.06 to 1.16" to read "1.00 to 1.22."

d(4). Change "1.26 to 1.42" to read "1.21 to 1.47."

e(4). Change "1.90 to 2.10" to read "1.80 to 2.20."

g(4). Change "2.58 to 2.85" to read "2.45 to 2.99."

h.(4). Change "3.25 to 3.60" to read "3.09 to 3.77."

i(4). Change "4.30 to 4.75" to read "4.08 to 4.98."

j(4). Change "5.15 to 5.68" to read "4.88 to 5.96."

k(4). Change "6.2 to 6.8" to read "5.85 to 7.15."

l(4). Change "7.32 to 8.1" to read "6.94 to 8.48."

n(4). Change "9.6 to 10.8" to read "9.18 to 11.22."

o(4). Change "12.1 to 13.3" to read "11.4 to 14.0."

p(4). Change "19 to 21" to read "18.0 to 22.0."

q(4). Change "25.3 to 28" to read "24.0 to 29.4."

r(4). Change "35.2 to 39" to read "33.4 to 40.8."

t(4). Change "51.5 to 57" to read "48.9 to 59.7."

u(4). Change "74 to 82" to read "70.2 to 85.8."

v(4). Change "115 to 127" to read "108.9 to 133.1."

Page 51, paragraph 38, Performance standard column. Make the following changes:

2c. Change "150 volts ± 3 " to read "150 volts ± 6 ."

2d. Change "130 volts ± 3 " to read "130 volts to ± 6 ."

2e. Change "40 volts ± 2 (4 volts ± 1)" to read "40 volts ± 2 (4 volts \pm (F range, TV-7D/U only))."

2f. Delete "(F range, TV-7D/U only)."

2g. The chart is superseded as follows:

g. Filament Voltage.

<i>Filament voltage switch position</i>	<i>TV-7U'</i>	<i>Performance standard TV-7A/U'</i>	<i>TV-7B/U'</i>	<i>TV-7D/U'</i>
.6	0.65-0.76	0.65-0.72	0.65-0.72	0.62 to 0.75
1.1	1.05-1.15	1.06-1.20	1.06-1.16	1.00 to 1.22
1.5	1.25-1.40	1.28-1.42	1.26-1.42	1.21 to 1.47
2.0	1.90-2.10	1.90-2.25	1.90-2.10	1.80 to 2.20
2.5	2.58-2.85	2.58-2.85	2.58-2.85	2.45 to 2.99
3.0	3.15-3.60	3.15-3.60	3.25-3.60	3.09 to 3.77
4.3	4.25-4.75	4.30-4.75	4.30-4.75	4.08 to 4.98
5.0	5.15-5.65	5.35-5.95	5.15-5.68	4.88 to 5.96
6.3	6.20-6.80	6.60-7.20	6.20-6.80	5.85 to 7.15
7.5	7.35-8.10	7.40-8.20	7.32-8.10	6.94 to 8.48
10	9.60-10.8	9.80-11.0	9.60-10.8	9.18 to 11.22
12.6	12.3-13.5	12.3-13.5	12.1-13.3	11.4 to 14.0
20	19.0-21.0	19.8-22.0	19.0-21.0	18.0 to 22.0
25	25.3-28.0	26.8-28.2	25.3-28.0	24.0 to 29.4
35	35.2-39.0	36.5-39.5	35.2-39.0	33.4 to 40.8
50	51.5-57.0	51.5-57.0	51.5-57.0	48.9 to 59.7
75	74.0-82.0	74.0-82.0	74.0-82.0	70.2 to 85.8
117	116-128	112-121	115-127	108.9 to 133.1

Page 55, appendix. Delete "TM 11-6625-274-20P" and "TM 11-6625-274-35P" in their entirety and substitute:

TM 11-6625-274-25P Organizational, DS, GS, and Depot Maintenance Repair Parts and Special Tool Lists: Test Sets, Electron Tube TV-7/U, TV-7A/U, TV-7B/U, and TV-7D/U.

By Order of the secretary of the Army

FRED C. WEYAND

*General, United States Army
Chief of Staff*

Official:

PAUL T. SMITH

*Major General, United States Army
The Adjusted General*

Distribution:

Active Army:

USMA (2)	Fort Gillem (10)
COE (1)	LBAD (14)
TSG (1)	SAAD (30)
USAARENBD (1)	TOAD (14)
DARCOM (1)	SHAD (3)
TRADOC (2)	Units org under fd TOE:
ARADCOM (2)	11-35
ARADCOM Rgn (2)	1136
OS Maj Comd (4)	11-37
MICOM (2)	11-38
LOGCOMDS (3)	11-39
TECOM (2)	1145
USAIB (2)	11-46
USAEUR (4)	11-85
USACC (4)	11-86
MDW (1)	11-87
Armies (2)	11-95
Corps (2)	11-96
HISA (Ft Monmouth) (33)	11-97
Svc Colleges (1)	11-98
USASESS (5)	11-117
USAADS (2)	11-127
USAFAS (2)	11-137
USAARMS (2)	11-147
USAIS (2)	11-215
USAES (2)	11-216
USAINTC (3)	11-217
MAAG (1)	11-218
USARMIS (1)	11-225
SIGFLDMS (1)	11-226
USAERDAA (1)	11-237
USAERDAW (1)	11-247
Instls (1) except	11-347
Fort Gordon (10)	11-357
Fort Huachuca (10)	11-358
Fort Carson (5)	11377
Ft Richardson (ECOM Ofc) (2)	11-500 (U-AC)

NC State AC (3), Units — Same as Active Army.

USAR: None

For explanation of abbreviations used see AR 310-50.

GPO 901-492

CHANGE }
No. 4 }

HEADQUARTERS
DEPARTMENT OF THE ARMY
WASHINGTON, D.C., 8 July 1966

DS, GS, and Depot Maintenance Manual

TEST SETS, ELECTRON TUBE TV-7/U, TV-7A/U, TV-7B/U, AND TV-7D/U

TM 11--6625-274-35, 30 June 1960, is changed as follows:

Page S. paragraph 1. Make the following changes:

Delete subparagraph c as changed by C 3, 13 December 1963, and Substitute:

c. The direct reporting by the individual user of errors, omissions, and recommendations for improving this manual is authorized and encouraged. DA Form 2028 (Recommended Changes to DA Publications) will be used for reporting these improvement recommendations. This form will be completed using pencil, pen, or typewriter and forwarded direct to Commanding General, U.S. Army Electronics Command, ATTN: AMSEL-MR-NMP-AD, Fort Monmouth, N.J. 07703.

Delete paragraph 1.1 as added by C 3, 13 December 1963, and substitute:

1.1. Index of Publications

Refer to the latest issue of DA Pam 310-4 to determine whether there are new editions, changes, or additional publications pertaining to the equipment. DA Pam 310-4 is an index of current technical manuals, technical bulletins, supply manuals (types 7, 8, and 9), supply bulletins, lubrication orders, and modification work orders available through publications supply channels. The index lists the individual parts (-10, -20, -35P, etc.) and the latest changes to and revisions of each equipment publication.

Page 21, paragraph 16c, chart, step 3, "Correction" column, item 2. (As changed by C 3, 13 Dec 63) Change "resistance of" to transformer.

Page 38. (As changed by C 3, 13 Dec 63) Delete paragraph 17 and substitute:

17. Dc Resistance of Transformer T101

The dc resistances of the transformer windings should be checked when the sc voltage readings

vary from those shown in figures 42(2), 43, and 44(2). Resistance measurements are taken to locate shorts between windings, shorts to ground, open windings, and high resistance connections. The dc resistances of the transformer windings will vary widely with each manufacturer's design and should not be the determining factor for replacement. Typical measurements taken from three different Test Sets, Electron Tube TV-7 (•)/U are shown in the following chart:

Terminals	Transformer a (ohms)	Transformer b (ohms)	Transformer c (ohms)
1-2.....	12.5.....	2.5.....	10
3-5.....	Less than 1...	Less than 1...	Less than 1
6-8.....	Less than 1...	Less than 1...	Less than 1
9-10.....	75.....	45.....	80
11-12.....	75.....	42.....	70
11-13.....	80.....	48.....	78
14-15.....	3.....	1.....	3
16-17.....	140.....	120.....	150
16-18.....	270.....	250.....	300
19-31.....	Less than 1...	Less than 1...	Less than 1
19-32.....	3.....	2.5.....	2.5
19-33.....	6.....	5.....	4
19-34.....	10.....	7.5.....	7
19-35.....	17.....	12.....	10.5
19-36.....	26.....	19.....	16
19-37.....	42.....	31.....	26

Page 39, paragraph 22. (As changed by C 3, 18 Dec. 63) Change paragraph 22 to 23 and add the following note after the paragraph heading.

Note. Be sure to perform the plate voltage and line adjust circuit test before performing the bias voltage test.

Page 40, paragraph 23. (As changed by C 3, 13 Dec. 63) Change paragraph 23 to 22, and add the following note after the paragraph heading:

Note. Be sure to perform the plate voltage and line adjust circuit test before performing the bias voltage test.

*The change supercedes, C 3 December 1963.

Page 60, paragraph 37. (As changed by C 3, 13 Dec 63) Make the following changes:

Subparagraph a(3). Add: and 12AT7.

Subparagraph C, chart, step No. 1, "Performance standard" column. Delete subparagraph c and substitute:

c. Multimeter should indicate 180,000 ohms \pm 18,000 when testing TV-7/U, TV-7A/U, and TV-7B/U. When testing TV-7D/U, the multimeter should read 180,000 ohms \pm 10 percent when

Page 52. Add chapter 5 after chapter 4:

the FUNCTION SWITCH is set to A, B, C, D, or E. position. When the FUNCTION SWITCH is set to the F position, the multimeter should read 37,300 ohms \pm 10 percent.

Step. No. 2, "Procedure" column. Add 12AT7.

Step No. 3, "Equipment under test control settings" column. After "SUPPRESSOR: 8", add FILAMENT VOLTAGE: Any position other than OFF or BLST.

CHAPTER 5

DEPOT OVERHAUL STANDARDS

41. Applicability of Depot Overhaul Standards

The tests outlined in this chapter are designed to measure the performance capability of a repaired equipment. Equipment that is returned to stock should meet the standards given in these tests.

42. Applicable References

a. *Repair Standard.* Applicable procedures of the Army depots performing this test and the general standards for repaired test equipment given in TB SIG 355-1, TB SIG 355-2, and TB SIG 355-3 form a part of the requirements for testing this equipment.

b. *Technical Publication.* The technical publication applicable to the equipment to be tested is indicated below.

Title	Number
Operator's and Organizational Maintenance Manual: Test Sets, Electron Tube TV-7/U, TV-7A/U, TV-7B/U, and TV-TD/U.	TM 11-6625-274-12

c. Modification Work Orders. Perform all modification work orders applicable to this equipment before making the tests specified. DA Pam 810-4 lists all available MWO's.

43. Test Facilities Required

The following items are required for depot testing:

Item	Technical manual	Common name
Multimeter TS-352(*)/U.	TM 11-5527 . . .	Multimeter.
Voltmeter, Meter ME-30A/U, or Voltmeter, Electronic ME-30B/U or ME-30C/U.	TM 11-6625-320-12.	Voltmeter.
Decade Resistor ZM-16/U.	TM 11-5102.	
Tube Socket Adapter MX-1258/U.	-----	Tube socket adapter.
Variable Transformer CN-16/U.	-----	Variable transformer.

44. General Test Requirements

All tests will be conducted under the following conditions:

- Tests will be made at room temperature.
- The equipment will be on at least 20 minutes before tests are made.

45. Calibration Test

Perform the test indicated in paragraph 35.

46. Voltage Tests

Perform the tests indicated in paragraph 36.

47. Operational Tests

Perform the tests indicated in paragraph 87. Page 55. Make the following changes:

Figure 44② (sheet 2), switch S109, section F. Delete the connection between contacts D and E and substitute 2 connections between C and E.

Appendix. (As changed by C 3, 13 Dec 63) Delete DA Pam 310-4, MWO 6625-274-35/1, TM 11-2661, and TM 11-5132 and substitute:

DA Pam 310-4.. Military Publications: Index of Technical Manuals, Technical Bulletins, Supply Manuals (types 7, 8, and 9), Supply Bulletins, Lubrication Orders, and Modification Work Orders.

TB SIG 355-1__ Depot Inspection Standard for Repaired Signal Equipment.

TB SIG 355-2__ Depot Inspection Standard for

By Order of the Secretary of the Army:

Official:

J. C. LAMBERT,
*Major General, United States Army,
The Adjutant General.*

Refinishing Repaired Signal Equipment.

TB SIG 355-3 -- Depot Inspection Standard for Moisture and Fungus Resistant Treatment.

TM 11-6625-316-12 ----- Operator and Organizational Maintenance Manual: Test Sets, Electron Tube TV-2/U, TV-2A/U, TV-2B/U, and TV-2C/U.

TM 11-6625-320-12 ----- Organizational Maintenance Manual: Voltmeter, Meter ME-30A/U and Voltmeters, Electronic ME-30B/U, ME-30C/U, and ME-30E//U.

HAROLD K. JOHNSON,
*General, United States Army,
Chief of Staff.*

Distribution:

Active Army:

USASA (2)
 CNGB (1)
 CC-E (7)
 Dir of Trans (1)
 CofEngrs (1)
 TSG (1)
 CofSpts (1)
 USAAESWBD (5)
 USAAVNTBD (5)
 USARADB (5)
 USACDCEA (1)
 USACDCCBRA (1)
 USACDCCEA (1)
 USACDCOA (1)
 USACDCQMA (1)
 USACDCTA (1)
 USACDCTA (1)
 USACDCADA (1)
 USACDCARMA (1)
 USACDCAVNA (1)
 USACDCARTYA (1)
 USACDCSWA (1)
 USACDCCEA, Ft Huachuca (1)
 USACDCEC (10)
 USCONARC (5)
 ARADCOM (5)
 ARADCOM Rgn (2)
 LOGCOMD (2)
 USAMC (5)
 USAMICOM (4)
 USASTRATCOM (4)
 MDW (1)
 Armies (2)
 Corps (2)
 USAC (3)
 Div (2)
 507th USASA Gp (5)
 508th USASA Gp (5)
 318th USASA Bn (5)
 319th USASA Bn (5)
 320th USASA Bn (5)
 177th USASA Co (5)
 182d USASA Co (5)
 183rd USASA Co (5)
 184th USASA Co (5)
 1st USASA Fld Sta (5)
 2d USASA Fld Sta (5)
 3rd USASA Fld Sta (5)
 4th USASA Fld Sta (5)
 5th USASA Fld Sta (5)

9th USASA Fld Sta (5)
 12th USASA Fld Sta (5)
 13th USASA Fld Sta (5)
 14th USASA Fld Sta (5)
 15th USASA Fld Stat (5)
 102d USASA Det (5)
 103rd USASA Det (5)
 104th USASA Det (5)
 400th USASA Det (5)
 401st USASA Det (5)
 402d USASA Det (5)
 403rd USASA Det (5)
 USATC (2)
 USMA (5)
 Svc Colleges (2)
 Br Svc Sch (2)
 USACSS (5)
 WRAMC (1)
 Army Pic Cen (2)
 USASTRATCOM-SEA (5)
 USATCFE (5)
 Instl (2) except
 Ft Monmouth (70)
 Ft Hancock (4)
 Ft Gordon (10)
 Ft Huachuca (10)
 Ft Carson (21)
 Ft Knox (12)
 WSMR (5)
 Gen Dep (2)
 Sig Sec, Gen Dep (5)
 Sig Dep (12)
 Army Dept (2) except
 LBAD (14)
 TOAD (14)
 LEAD (7)
 SAAD (5)
 CHAD (3)
 SAAD (30)
 FTWOAD (10)
 SHAD (3)
 SVAD (5)
 ATAD (10)
 AMS (1)
 USACRREL (2)
 USAERDAA (2)
 USAERDAW (13)
 Sig FLDMS (2)
 MAAG, Republic of China (6)
 MAAG, Thailand (5)

MAAG, Vietnam (6)
 MAAG, Iran (5)
 MAAG, Taiwan (5)
 JUSMMAT (5)
 USMTMSA (5)
 GENMISH (5)
 KMAG (5)
 USARMIS: Honduras (5)
 Guatemala (5)
 Chile (5)
 Venezuela (5)
 Paraguay (5)
 Ecuador (5)
 Bolivia (5)
 Colombia (5)
 El Salvador (5)

Units organized under following TOE's (2 each) :

11-6	11-106
11-7	11-117
11-8	11-127
11-35	11-137
11-36	11-147
11-37	11-155
11-38	11-156
11-39	11-157
11-45	11-158
11-46	11-215
11-56	11-216
11-57	11-217
11-58	11-218
11-85	11-225
11-86	11-226
11-87	11-237
11-95	11-247
11-96	11-347
11-97	11-357
11-98	11-358
11-99	11-377
11-106	
11-500	(FH, FJ, FK, FO, FP, FQ, FR, GH, GI, GJ, GR, KA, KC, NA, NB, NC, RA, RB, RC, RD, RE, RF, RH, RI, RK, RL, RM, RN-RU, TC, TE, TF, TG, TK)
11-587	11-597
11-592	11-608

NG: State AG (3) ; units-same as Active Army except allowance is one copy to each unit.

USA R: None.

For explanation of abbreviations used, see AR 320-50.

U. S. GOVERNMENT PRINTING OFFICE: 1969-342-014/2212
 907-707

TECHINICAL MANUAL }
 No. 11-6625-274-35 }

HEADQUARTERS,
 DEPARTMENT OF THE ARMY
 WASHINGTON 25, D.C., 30 June 1960

TEST SETS, ELECTRON TUBE TV-7/U, TV-7A/U, TV-7B/U, AND TV-7D/U

		Paragraph	Page
CHAPTER 1.	THEORY		
Section I.	General		
	Scope	1	3
	Internal differences in models	2	3
Section II.	General theory		
	Block diagram analysis	3	6
	Function of equipment	4	6
	Basic theory of mutual conductance test	5	7
Section III.	Circuit theory		
	Power supply circuits	6	8
	Line voltage test circuit	7	9
	Shorts and noise test circuit	8	10
	Rectifier test circuit	9	11
	Mutual conductance test circuit	10	14
	Gas test circuit	11	16
	Special switching circuits	12	17
CHAPTER 2.	TROUBLESHOOTING		
	General instructions	13	20
	Troubleshooting procedures	14	20
	Tools and test equipment required	15	20
	Isolating troubles	16	20
	Dc resistances of transformer T101	17	38
	Replacement of socket-saver adapters (TV-7D/U)	18	38
CHAPTER 3.	TESTS, ADJUSTMENTS, AND CALIBRATION PROCEDURES		
Section I.	Tests and adjustments		
	General	19	39
	Test equipment and parts required for tests	20	39
	Test requirements	21	39
	Bias voltage test	22	39
	Plate voltage and line adjust circuit test	23	40
	Screen grid voltage test	24	40
	Short circuit tests	25	40
	Simulated tube test	26	41
Section II.	Calibration procedures		
	Shunt control	27	42
	RANGES C of FUNCTION SWITCH	28	42

*This manual, together with TM 11-6625-274-12, 14 June 1960, supersedes TM 11-5083, 29 September 1953, including C1, 2 September 1955; C2, 8 February, 1956; C3, 1 April 1959; and C4, 26 August, 1959.

CHAPTER 4. FOURTH ECHELON TESTING PROCEDURES AND FINAL TESTING

Section		Paragraph	Page
I.	Fourth echelon testing procedures		
	General	29	44
	Test equipment and materials required	30	44
	Test facilities	31	44
	Modification work orders.	32	44
	Moistureproofing and fungiproofing	33	45
	Physical tests and inspection	34	45
	Calibration test	35	47
	Voltage tests	36	(fold-out)
	Operational tests'	37	(fold-out)
	Performance standard summary	38	61
II	Final testing		
	Purpose of final testing	39	52
	Final tests	40	52
APPENDIX	REFERENCES		55

CHAPTER 1

THEORY

Section I. GENERAL

1. Scope

a. This manual covers field and depot maintenance for Test Sets, Electron Tube TV-7/U, TV-7A/U, TV-7B/U, and TV-7D/U. It includes instructions appropriate to fourth and fifth echelons for troubleshooting, testing, calibrating, and repairing the equipment; and lists the tools, materials, and test equipment required for fourth and fifth echelon maintenance. Detailed functions of the equipment are covered in paragraphs 3 through 12.

b. The complete technical manual for this equipment includes three other publications: TM 11-6625-274-12, TM 11-6625-274-12P, and TM 11-6625-274-35P.

c. Forward comments concerning this manual to the Commanding Officer, U. S. Army Signal Materiel Support Agency, ATTN: Publications Engineering Department, Fort Monmouth, N. J.

Note. For applicable forms and records, see paragraph 2, TM 11-6625-274-12

2. Internal Differences in Models

a. An antiparasitic bead' (fig. 1) made of ferrite is placed on the lead soldered to terminal 5 of tube test socket X105 and on the lead soldered to terminal 2 of tube test socket X106 in the TV-7B/U. Antiparasitic beads are also placed on the leads soldered to all tube test sockets of the TV-7D/U, except on the sockets and the terminals listed below.

- (1) Tube test sockets X109 and X110.
- (2) Pins 1 and 4 of tube test socket X103.
- (3) Pins 1 and 4 of tube test socket X105.
- (4) Pin 8 of tube test socket X111.

b. Other internal differences are listed in the chart below. For external differences, see TM 11-6625-274-12.

Component	Test set, electron tube				
	TV-7/U	TV-7A/U		TV-7B/U	TV-7D/U
		Serial numbers 1 through 1200	Serial numbers 1201 through 9492		
R113	41 ohms, fixed	41 ohms, variable	1,000 ohms, variable	1,000 ohms, variable	1,000 ohms, variable
R114	280 ohms, fixed	280 ohms, variable	280 ohms, variable	350 ohms, variable	350 ohms, variable
R115	41 ohms, fixed	41 ohms, variable	1,000 ohms, variable	1,000 ohms, variable	1,000 ohms, variable
R117, R123, R124, and R125	Mounted on E106	Mounted on E106	Mounted on E106	Mounted on resistor mounting board	Mounted on resistor mounting board
R124	245K ohms	245K ohms	245K ohms	225K ohms	225K ohms
R130	8,500 ohms, no C tap	8,500 ohms, no C tap	9,500 ohms, C tap used	9,500 ohms, C tap used	9,500 ohms, C tap used
R131 and R132	Not used	10,000 to 20,000 ohms*	10,000 to 20,000 ohms*	Not used	Not used
R133	Not used	680 ohms	Not used	Not used	Not used
R134 (45 ohms)	Not used	Not used	Used	Designated as R135	Designated as R135

*The value of resistors R131 and R132 (if used), which ranges from 10,000 to 20,000 ohms, is determined in production.

Component	Test set, electron tube				
	TV-7/U	TV-7A/U		TV-7B/U	TV-7D/U
		Serial numbers 1 through 1200	Serial numbers 1201 through 9492		
R134 (40,000 ohms)	Not used	Not used	Not used	Used	Used
R135 (45 ohms)	Not used	Not used	Used	Designated as R137	Designated as R137
R137	Not used	Not used	Not used	45 ohms	45 ohms
R139	Not used	Not used	Not used	Not used	350 ohms, variable
R140	Not used	Not used	Not used	Not used	2,700 ohms
R141	Not used	Not used	Not used	Not used	47,000 ohms
CR101	Mounted on E106 or S110	Mounted on S110	Mounted on S110	Mounted on S110	Mounted on S110
S109	6 sections	6 sections	6 sections	6 sections	8 sections
V102	5Y3GT ^b	5Y3WGT ^b	5Y3WGT ^b	5Y3WGTA	5Y3WGTA

^bWhen replacing, use a 5Y3WGTA.

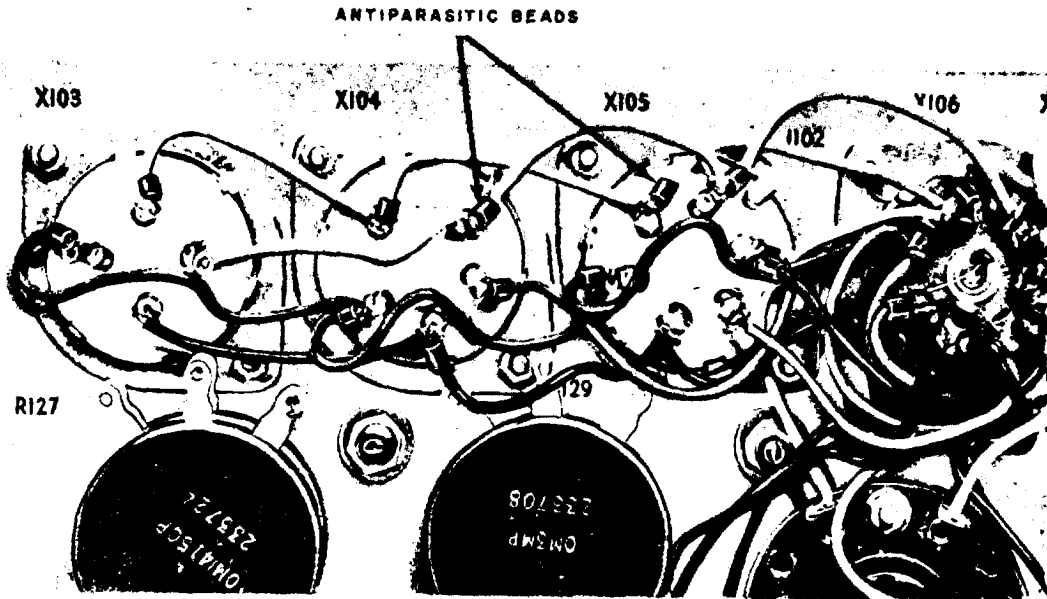

TM 6625-274-36-1

Figure 1. Antiparasitic beads (used on TV-7B/ U and TV-7D/U), typical application.

Section II. GENERAL THEORY

3. Block Diagram Analysis (fig. 2)

The block diagram illustrates the several major circuit sections of the test set and their relation to each other. Voltage from a 115-volt alternating current (ac) power source is reduced and standardized by the operation of the line adjust circuit. For line voltage adjustments, pushbutton 1 — LINE ADJ. is depressed. Voltage is then applied to meter M101 through metallic rectifier CR101. When the meter pointer is directly over the LINE TEST mark, the voltages for the test circuits are standardized.

a. The power supply circuit consists basically of transformer T101 and rectifier tubes V101 and V102. The power supply provides ac voltages for the mutual conductance tests and for the filaments or the heaters of V101, V102, and the tube under test, and provides direct current (dc) voltages for the tube under test. Voltage is applied to the tube under test through FILAMENT VOLTAGE switch S108 and the selector switches.

b. Pushbutton switch assembly S110 provides a selection of various combinations of plate, screen, bias, and signal voltages that are required to test the different types of tubes. Proper selection of these voltages is made through the setting of the selector switches *before* the voltages are applied to the tube under test. The selector switches determine the test socket terminals to which the various test voltages are applied. The FUNCTION SWITCH serves a dual purpose: when shorts tests are made, positions No. 1 through 5 of the SHORTS section of the FUNCTION SWITCH permit the application of an ac voltage to the different elements of the tube under test. When positions A through E (A through F, TV-7D/U) of the RANGES section of the FUNCTION SWITCH are used, the sensitivity of meter M101 and the magnitude of the signal voltage are controlled. Meter M101 indicates the condition of the tube under test.

4. Function of Equipment

Test Set, Electron Tube TV-7(*)/U employs the dynamic mutual conductance method to test amplifier tubes. The test set consists princi-

pally of a power supply to furnish the correct voltages to the tubes under test, a line test circuit, and five tube-testing circuits. These five circuits are shorts, noise test, rectifier test, mutual conductance test, and gas test. Controls and switches permit the application of proper test voltages to the tube under test, and a meter or an indicating lamp displays the test results. The relationship among the principal circuits and parts of the test set are shown in the block diagram (fig. 2).

a. *Power Supply* (fig. 3). The power supply consists of three supply voltage circuits, each supplied by transformer T101.

- (1) The filament supply consists of secondary windings No. 7 and FILAMENT VOLTAGE switch S108. The FILAMENT VOLTAGE switch is used to select any one of 18 different filament voltages for the tube or panel lamp under test, ranging from 0.6 volt to 117 volts ac. PILOT lamp E102 is connected between terminals 22 and 28 of secondary No. 7, and lights when the POWER switch is set to the ON position.
- (2) Full-wave rectifier tube V101 supplies unfiltered, pulsating dc voltage for the plate of the tube under test. Secondaries No. 1 and No. 2 supply the ac voltage for the plates of V101. Filament voltage for V101 is supplied by secondary No. 6.
- (3) Grid bias voltage and screen grid voltage is supplied to the tube under test by full-wave rectifier tube V102. Secondaries No. 4 and No. 5 supply the operating voltages for V102. Various amounts of bias voltage for the tube under test can be selected by changing the setting of the BIAS control. A separate winding on transformer T101 supplies an ac signal voltage to the grid circuit of the tube under test. Screen grid voltage may be varied by adjusting the taps on resistor R130. Pushbutton 2 — DIODE permits either the normal screen grid voltage or a low screen grid voltage to be applied to the tube under test.

6. *Line Voltage Test Circuit.* The line voltage test circuit primarily consists of meter M101, part of transformer T101, and R126. Line voltage fluctuations across the primary of transformer T101 can be compensated for by adjusting LINE ADJUST control R126, a rheostat, until the meter pointer is directly over the LINE TEST mark. Frequent adjustment of this control may be necessary, depending on the stability of the line voltage. When the LINE ADJUST control is correctly set, proper test potentials are applied to the elements of the tube under test.

c. *Shorts and Noise Test Circuit.* The same circuit is used to test tubes for self-generated noise and for interelectrode shorts.

- (1) A short between any two elements of the tube under test will cause neon SHORTS lamp E101 to glow. The SHORTS section of FUNCTION SWITCH S109 is used to select any tube electrode and to test it for shorts to all other elements. In some instances, certain elements within a vacuum tube are intentionally shorted together. Refer to the test data book

on the cover of the test set before discarding a shorted tube.

- (2) Noise generated within a tube is often caused by the vibration of loose tube elements or by intermittent contact between elements. When tube elements vibrate, or when intermittent disturbances between elements are too brief to cause the neon lamp to indicate a short, an audible means can be used to detect the noise produced (para 22, TM 11-6625-274-12). The SHORTS section of the FUNCTION SWITCH is also used for the noise test.

d. *Rectifier Test Circuit.* The quality of diode detectors and vacuum tube rectifiers is checked by measuring the dc emission of the tube under static conditions. Cold cathode-type tubes are tested similar to diode detectors and vacuum tube rectifiers, except a higher voltage is applied to the tube. Various fixed test voltages are selected by pushbuttons 2 — DIODE, 6 — OZ4, and 7 — RECT. The amount that the pointer of meter M101 deflects is a measure of the efficiency of electron emission of the tube.

e. *Mutual Conductance Test Circuit.* This

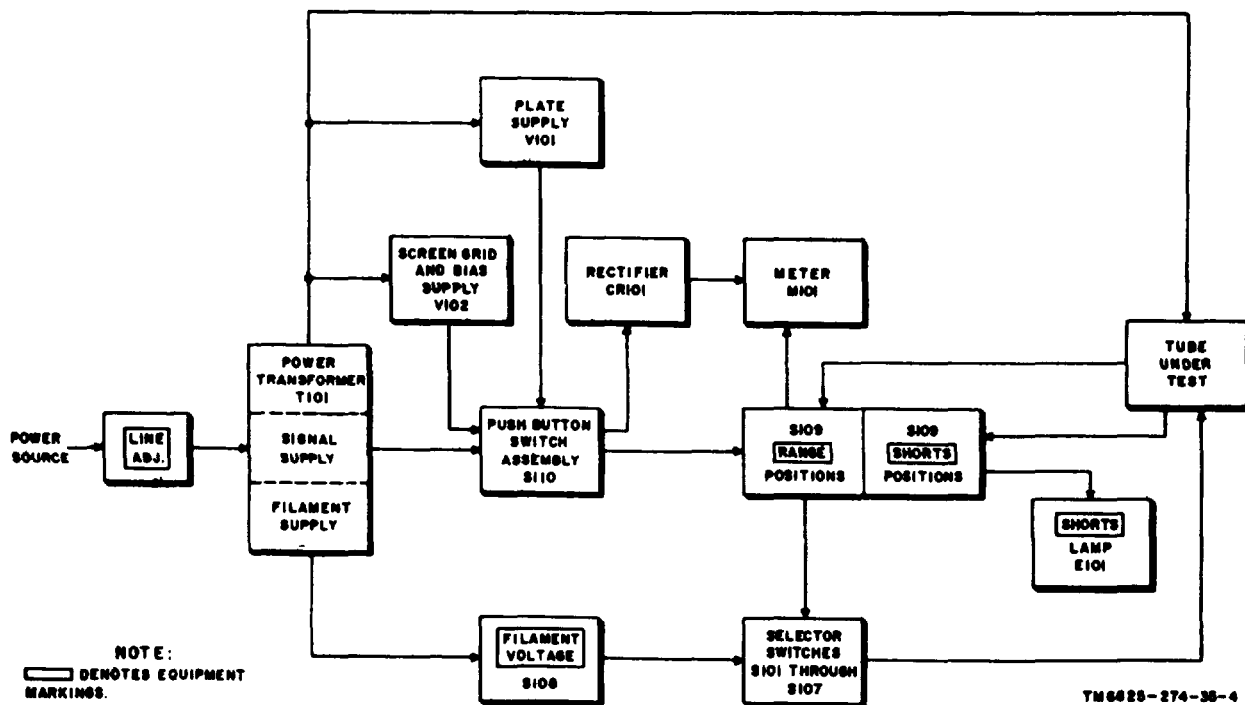
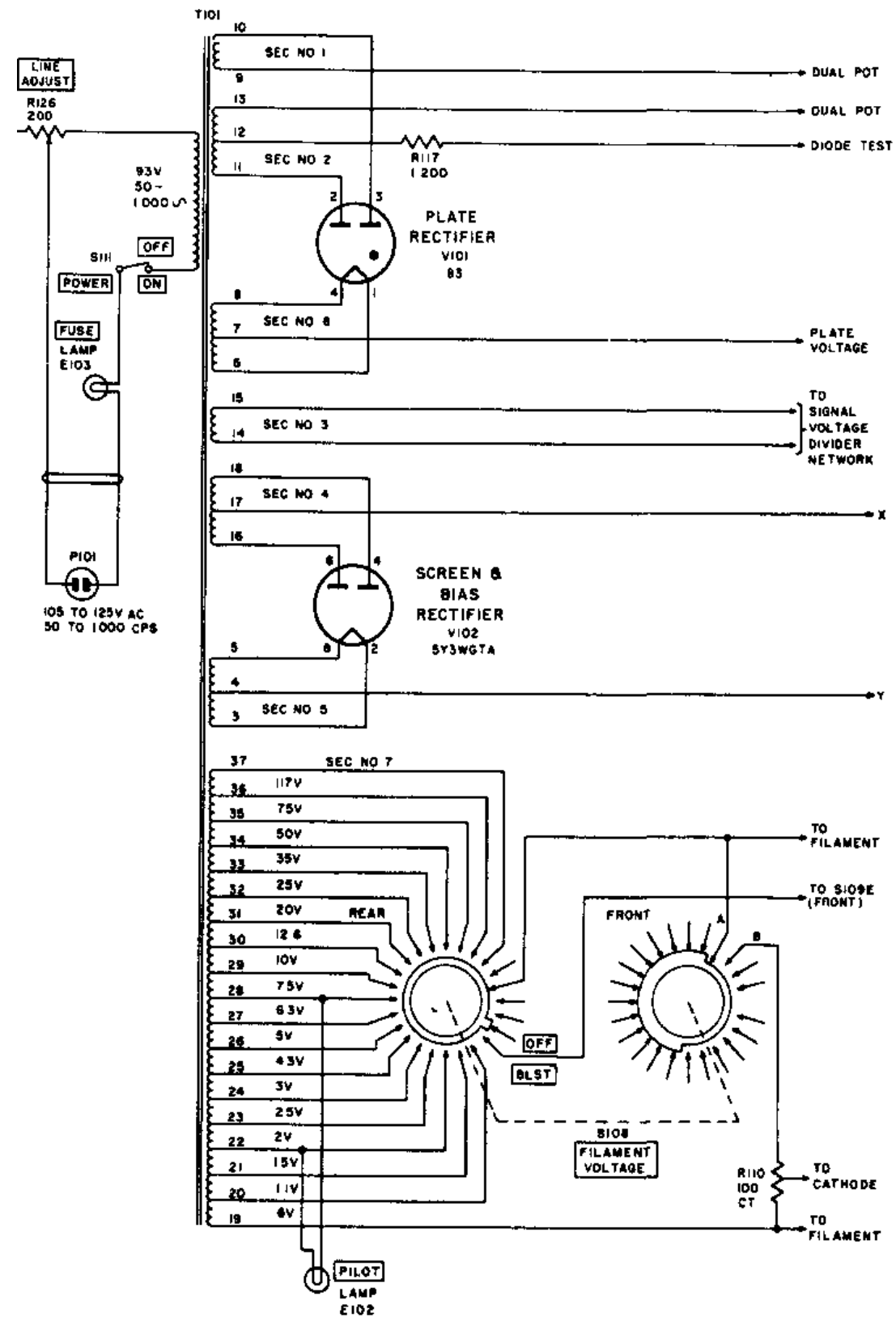

Figure 2. Test Set, Electron Tube TV-7(*)/U, block diagram.



A POWER SUPPLY

NOTES

- 1 UNLESS OTHERWISE INDICATED RESISTANCES ARE IN OHMS AND CAPACITANCES ARE IN UUF
- 2 RESISTOR R133, 680 OHMS, IS USED ONLY ON THE TV 7A/U SERIAL NUMBERS 1 THROUGH 1200
- 3 RESISTOR R140 IS ONLY IN THE CIRCUIT FOR RANGE [B] OF [FUNCTION SWITCH] S109
- 4 DENOTES EQUIPMENT MARKINGS

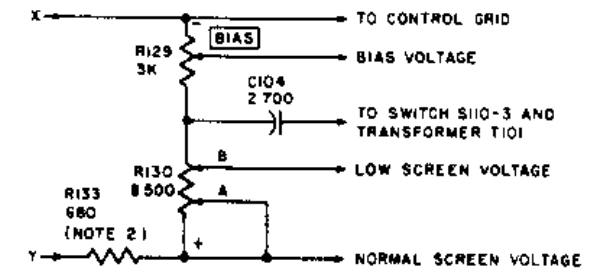

B VOLTAGE DIVIDER FOR BIAS VOLTAGE AND SCREEN VOLTAGE TV-7/U AND TV 7A/U SERIAL NUMBERS 1 THROUGH 1200

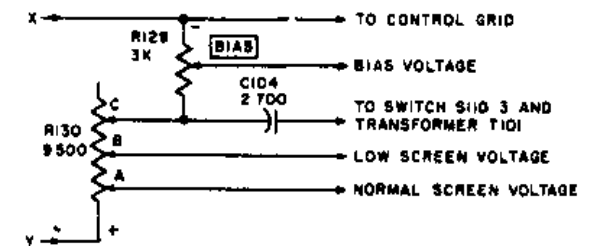

C VOLTAGE DIVIDER FOR BIAS VOLTAGE AND SCREEN VOLTAGE TV 7A/U SERIAL NUMBERS 1201 THROUGH 9492 AND TV-7B/U

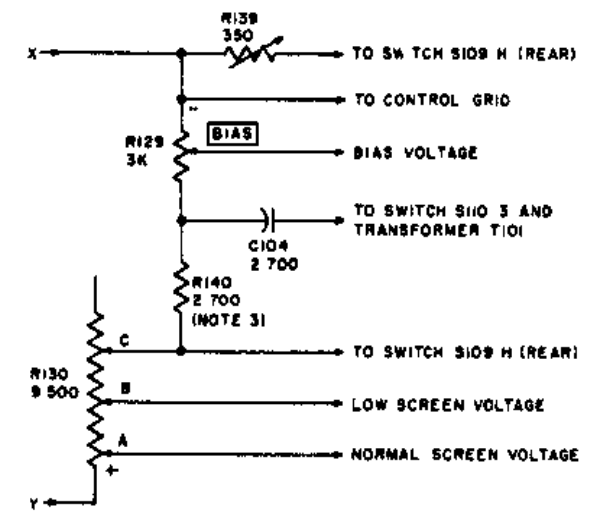

D VOLTAGE DIVIDER FOR BIAS VOLTAGE AND SCREEN VOLTAGE TV-7D/U

circuit gives an indication of the overall merit of amplifier tubes under simulated operating conditions, by measuring the mutual conductance (G_m) of the tube under test. When pushbutton 3 — MUT. COND. is depressed, the mutual conductance of the tube is indicated on meter M101 in terms of arbitrary units from 0 to 120. To convert the numerical value of the meter reading to mutual conductance in micromhos, refer to paragraph 20, TM 11-6625-274-12.

f. *Gas Test Circuit.* This circuit is used to check for the presence of excessive amounts of gas in vacuum-type tubes. Excessive gas is indicated by a change in the position of the meter pointer due to the shift in the operating points of the tubes because of gas current in the grid-to-cathode circuit. The gas test is performed by depressing first pushbutton 4 — GAS 1, then pushbutton 5 — GAS 2.

5. Basic Theory of Mutual Conductance Test

To better understand the function and operation of the mutual conductance test circuit used in this test set, a brief review of the basic principles used follows.

a. The two secondary windings of the transformer (fig. 4), which are energized from a 60-cycle power source, supply plate voltage to the full-wave rectifier tube. The inner end of each secondary winding connects to one side of a dc milliammeter (IG). A center-tapped resistor, R_m , is shunted across the milliammeter. The load, resistance R_L , is connected between the center tap of the transformer (momentarily neglecting resistor R_m) and the cathode of the rectifier, as in common full-wave rectifier circuits. When plate 2 is positive with respect to the cathode, electrons flow through the upper half of resistor R_m and through R_L , to the cathode, causing the meter pointer to deflect in one direction. When plate 1 is positive with respect to the cathode, electrons flow through the lower half of resistor R_m and through R_L to the cathode, causing the meter pointer to deflect in the opposite direction. With the load resistance fixed and with equal forces acting upon the meter each time the tube conducts, the meter pointer will indicate zero. The pointer cannot follow to

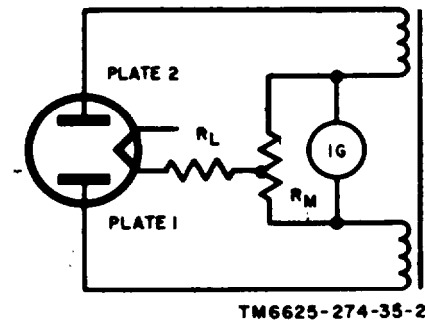

Figure 4. Rectifier diagram.

at the rate of conduction of the tube because of the inertia of the meter movement.

b. If the amplifier tube to be tested is substituted for the fixed load resistance and a fixed bias voltage E is applied to the tube (fig. 5), the meter will still indicate zero because the amplifier tube, under steady-state conditions, acts like a fixed resistance.

c. If, in addition to the bias voltage, an ac potential is applied between the control grid and the cathode of the tube under test, the circuit becomes equivalent to the one used for mutual conductance tests in the TV-7(*)/U. When the ac potential causes the bias voltage between the control grid and the cathode to become less negative, plate current through the tube will increase. Since the plate-cathode resistance has decreased, more current will flow through resistor R_m , and the deflecting force on the pointer of the meter will be greater than before the ac potential was applied. When the ac potential causes the bias voltage between the control grid and the cathode to become more negative on the other half cycle, the resistance of the tube under test will increase, plate current will decrease, and the deflecting force on the meter pointer will be less. With unbalanced current flow through the meter on adjacent half cycles and consequent unequal forces applied to the pointer of the meter, the deflection of the pointer will be proportional to the difference between the currents. Since the difference between the currents was created by the ac potential applied between the control grid and the cathode, the meter pointer will indicate the plate current changes produced by the applied grid voltage change. The meter, therefore, will indicate the mutual conductance (para 10a) of the tube under test.

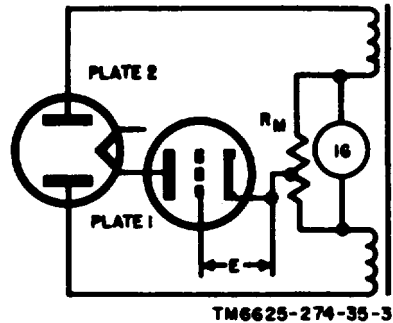

Figure 5. Basic mutual conductance circuit.

Section III. CIRCUIT THEORY

6. Power Supply Circuits

(fig. 3 and 42-44)

a. *General.* Input power to the primary of transformer T101 is supplied from a 105- to 125-volt ac, 50- to 1,000-cycles-per-second (cps) power source through FUSE lamp E103, POWER switch S111, and LINE ADJUST control R126 (A, fig. 3). The LINE ADJUST control (a rheostat), operated in conjunction with the line voltage test circuit (para 7), adjusts the voltage across the primary of transformer T101 to 93 volts ac.

b. *Plate Supply.* Plate rectifier tube V101 is a type 83 mercury vapor rectifier tube connected in a full-wave rectifier circuit. Secondaries No. 1 and No. 2 supply approximately 154 volts ac to the plates of the tube. Filament voltage is supplied by 5-volt secondary No. 6. The unfiltered, pulsating dc plate voltage output from the filament-cathode of tube V101 is tapped off at the center tap of secondary No. 6. Secondary No. 2 is tapped at 20 volts to supply voltage, through current limiting resistor R117, for emission tests on certain diode tubes.

c. *Screen and Bias Supply.* Secondary No. 4, 330 volts center tapped, supplies voltage to the plates of screen and bias rectifier tube V102, a type 5Y3WGTA (para 2b) rectifier tube, which is connected in a full-wave rectifier circuit. Filament voltage is supplied to V102 by secondary No. 5. A voltage divider (B, C, or D, fig. 3) is connected between terminals 4 and 17 of T101. The voltage divider provides "bias voltage for mutual conductance tests and screen grid voltage (when required) for the tube under test. When V102 conducts, current flow through R129 and R130 (and R133 (B, fig. 3))

produces a voltage drop across each resistor with a polarity as shown in B, C, and D of figure 3.

- (1) The bias voltage, applied to the tube under test, determined by the setting indicated in the test data book, can be varied by rotating the BIAS control knob on the front panel of the test set. This relocates the tap on resistor R129, thereby changing the difference in potential between the control grid and the cathode of the tube.
- (2) The normal screen grid voltage is +130 volts dc. If this voltage is too high for the tube under test, a lower screen grid voltage can be applied to the tube by depressing pushbutton 2 — DIODE. When pushbutton 2 — DIODE is depressed, the screen grid is disconnected from tap B on resistor R130 and is connected to tap A. The TV-7A/U, serial numbers 1 through 1200, also uses voltage-dropping resistor R133 (B, fig. 3) to reduce the screen grid voltage to a suitable value.
- (3) When the RANGES F position of the FUNCTION SWITCH is used, variable resistor R139 is connected in parallel with R129, and R140 is connected in series with R129. The addition of R139 and R140 (D, fig. 3) reduces the current through the voltage divider. The voltage drop across R130 is slightly decreased; the voltage drop across BIAS control R129 is greatly decreased, primarily due to adding a low resistance in parallel with the control.

- (4) Secondary No. 3 (A, fig. 3) Supplies a 5-volt ac signal voltage for mutual conductance tests. A voltage divider network consisting of R120, R121, and R122 (fig. 42-44), connected across this winding, also provides signal voltages of 1 volt and 0.5 volt, depending on the resistor or resistors used.

d. *Filament Supply.* Secondary No. 7 of T101 (A, fig. 3) supplies filament voltage to the tube under test and voltage for rectifier emission tests. Terminals 19 through 37 provide voltages from 0 volt to 117 volts, under load. No-load voltages will be slightly higher. As an example, the no-load voltage measured between terminals 19 and 37 will be approximately 121 volts with 93 volts across the primary. FILAMENT VOLTAGE switch S108 is used to select the desired filament voltage for the tube under test. The BLST. position of switch S108 enables ballast tubes to be tested for continuity, and supplies voltage to certain rectifier tubes for emission tests. Center-tapped resistor R110 prevents injection of the filament voltage into the grid signal voltage.

7. Line Voltage Test Circuit

(fig. 3 and 42-44)

The line voltage test circuit consists primarily of a bridge circuit connected parallel to terminals 19 and 37 of transformer T101. Meter M101, which can be switched into the bridge circuit, provides an indication of the proper adjustments of LINE ADJUST control R126.

a. The ac voltage between terminals 19 and 37 of T101 is applied to the rectifier bridge circuit through part of switch S110-1 and resistors R134 (TV-7B/U and TV-7D/U only) and R124. The rectifier bridge circuit, except for the TV-7A/U, consists of copper oxide rectifier CR101 and bridge-balancing resistors R123 and R125. On the TV-7A/U (fig. 42 and 43), in addition to bridge-balancing resistors R123 and R125, when meter shunt resistors R131 and R132 are used they are also part of the rectifier bridge circuit and are connected in parallel with copper oxide rectifier CR101. Resistors R131 and R132 are added to the bridge circuit, as required, during initial calibration of the line adjust circuit.

b. When pushbutton 1 — LINE ADJ. is depressed, meter M101 and filter capacitor C103

are connected in parallel with copper oxide rectifier CR101 and bridge-balancing resistors R123 and R125 (and meter shunt resistors R131 and R132, when used, on the TV-7A/U). At the same time, the rectifier bridge circuit is connected between terminals 19 and 37 of T101 through voltage-dropping resistor R124 and variable resistor R134 (TV-7 B/U and TV-7D/U only).

- (1) On the TV-7/U and TV-7A/U, the value of voltage-dropping resistor R124 is such that, when 121 volts ac (no load) exists between terminals 19 and 37 of transformer T101, and pushbutton 1 — LINE ADJ. is depressed, the meter pointer will indicate at LINE TEST.
- (2) On the TV-7B/U and TV-7D/U, the value of resistors R124 and R134 are such that, when 121 volts ac (no load) exists between terminals 19 and 37 of T101 and variable resistor R134 is properly adjusted, the meter pointer will indicate at LINE TEST when pushbutton 1 — LINE ADJ. is depressed.

c. When power is applied to the test set and the setting of resistor R126 is varied, the voltage across the primary and the secondaries of T101 will change. The meter pointer should indicate at LINE TEST when pushbutton 1 — LINE ADJ. is depressed and resistor R126 is properly adjusted.

d. Current flow through the line voltage test circuit is as follows:

- (1) When terminal 37 of T101 is negative with respect to terminal 19, the right-hand part of CR101 will conduct and the left-hand part of CR101 will not conduct. Current will flow from terminal 37 through one part of switch S110-1, variable resistor R134 (TV-7B/U and TV-7D/U only), and voltage-dropping resistor R124 to the junction of R123 and R125. The current will divide at this point. Some of the current will flow through R125; the remainder of the current will flow through R123, part of switch S110-1, meter M101 and filter capacitor C103, and another part of switch S110-1.

The total current in the circuit will flow through the right-hand part of CR101.

- (2) When terminal 19 is negative with respect to terminal 37, the left-hand part of CR101 will conduct and the right-hand part of CR101 will not conduct. Current will flow from terminal 19 through the left-hand part of CR101 to the junction of R123 and one part of switch S110-1. The current will divide at this point. Some of the current will flow through R123; the remainder of the current will flow through part of switch S110-1, meter M101 and filter capacitor C103, another part of switch S110-1, and R125. The total current in the circuit will flow through R124, variable resistor R134, and one part of switch S110-1 to terminal 37 of T101.

8. Shorts and Noise Test Circuit

(fig. 7 and 42-44)

a. Shorts Test Circuit.

- (1) The voltage across secondary No. 2 of transformer T101 is applied to a voltage divider consisting of resistors R107 and R108 (fig. 7). The voltage across R107 is applied to the elements of the tube under test through C102 and R109 and C105. Neon SHORTS lamp E101 is in parallel with C105 and R109. Capacitor C105 and resistor R109 eliminate internally generated harmonics that are a result of operating the test set on input line frequencies higher than 60 cps.
- (2) The voltage across R107 is applied to the elements of the tube under test when the selector switches are properly set and the FUNCTION

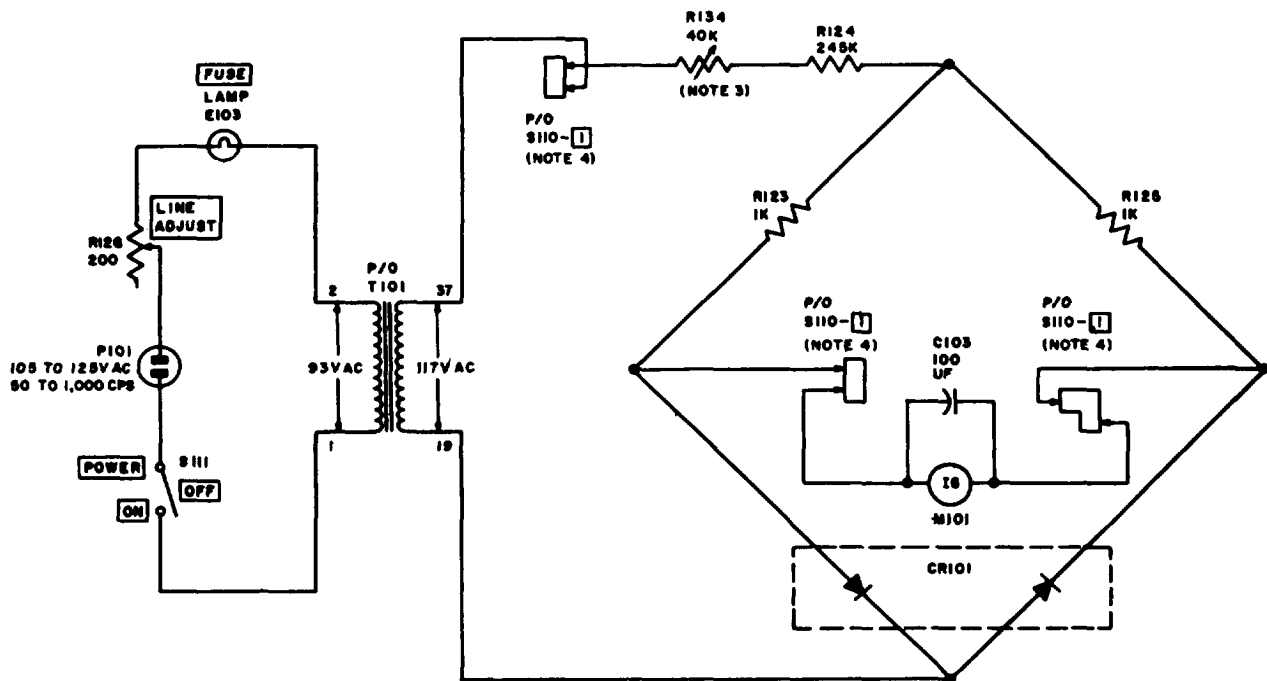

NOTES:

1. UNLESS OTHERWISE INDICATED, RESISTANCES ARE IN OHMS.
2. ON TV-7A/U, RESISTORS R131 AND R132 ARE EACH CONNECTED PARALLEL TO RECTIFIER CR101.
3. VARIABLE RESISTOR R134 IS USED ONLY ON TV-7B/U AND TV-7D/U.
4. SWITCH S110-1 IS SHOWN DEPRESSED.
5.  DENOTES EQUIPMENT MARKING.

TM6625-274-35-6

Figure 6. Simplified line voltage test circuit.

SWITCH is turned from positions 1 through 5. A short between two or more elements of the tube under test will complete the circuit between C102 and R109, C105, and the neon SHORTS lamp. The voltage applied to the SHORTS lamp will cause the gas to ionize, thereby producing a visual indication of an interelement short.

- (3) If the polarity of the applied voltage is such that terminal 13 of T101 is negative with respect to terminal 11, and a short exists between two elements of the tube under test, the current flow will be as follows:
- (a) The total current in the circuit will flow from terminal 13 of T101 through R108 to the junction of C102 and R107. The current will divide at this point. Some of the current will flow through R107 to terminal 11 of the transformer; the remainder of the current will flow through C102 and across the short within the tube under test to the junction of C105, R109, and SHORTS lamp E101. The reactance of C105 and the resistance of R109 are very high compared with the resistance of the conducting SHORTS lamp. The majority of the current, therefore, will flow through the SHORTS lamp to terminal 11 of T101.
- (b) When terminal 11 of T101 is negative with respect to terminal 13, current will flow to the junction of resistors R107 and R109, capacitor C105, and SHORTS lamp E101. Some of the current will flow through R107 to the junction of R108 and C102; the majority of the remaining current will flow through the SHORTS lamp, across the shorted elements within the tube under test, and through C102 to the junction of resistors R107 and R108. The total current in the circuit will flow through R108 to terminal 13 of T101.

b. *Noise Test Circuit.* The shorts test Circuit is also used when testing a tube for noise. NOISE test jacks J103 and J104 are used to connect a radio receiver or an audio amplifier (para 22, TM 11-6625-274-12) in parallel with SHORTS lamp E101 through isolating capacitor C101. Intermittent disturbances between the tube elements can often be made to occur by tapping a tube. Momentary shorts, which are too brief to be indicated by the SHORTS lamp, permit the alternating voltage across R107 to be applied to the neon lamp and cause a brief oscillation. The oscillations are reproduced and amplified by the radio receiver or the audit! amplifier and are heard as an audible signal similar to static.

9. Rectifier Test Circuit

(fig. 8, 9, and 42-44)

The rectifier test circuits in the TV-7(*)/U are similar to the simplified rectifier test circuit shown in figure 9.

a. The circuit shown in figures 8 and 9 is used when the rectifier tube under test is supplied with a test voltage of 35 volts ac.

- (1) Some diode tubes, such as the 6H6, use a test voltage of only 20 volts ac, which is supplied by part of secondary No. 2 of T101 (fig. 42-44). The actual voltage applied between the plate and the cathode is approximately 18 volts ac because of a voltage drop across current limiting resistor R117.
- (2) A test voltage of approximately 287 volts ac is applied to rectifier tubes of the cold cathode type, such as the OZ4.
- (3) Because of the different voltages required to test various types of diodes, the test circuits will necessarily be slightly different from the circuit shown in figures 8 and 9.

b. Filament voltage is supplied to the rectifier tube under test (fig. 8 and 9) from terminals 19 and 27 of transformer T101. When pushbutton switch S110-7 is depressed, 35 volts ac is applied between the cathode and the plate of the tube under test. The tube will conduct only when the plate is positive with respect to the cathode, thereby producing a pulsating dc flow through the circuit. The current through meter M101 is proportional to the electron emission of the tube, and the amount of deflec-

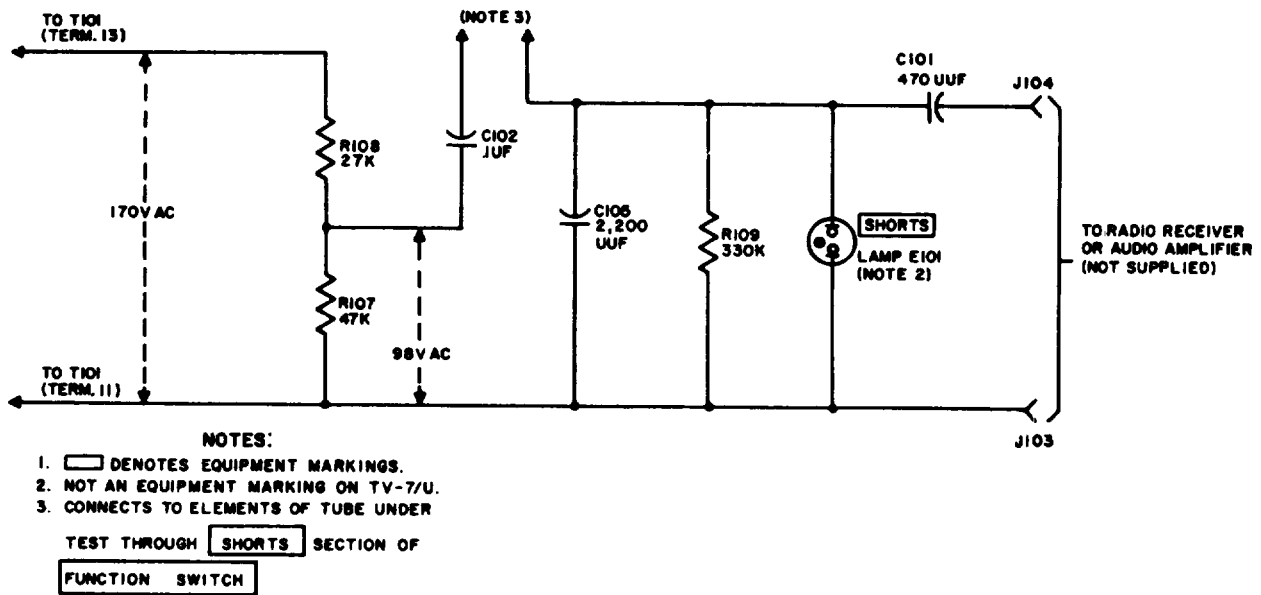

TM6625-274-35-7

Figure 7. Simplified shorts and noise test circuit.

tion of the meter pointer is a measure of the efficiency of electron emission of the tube.

c. The partial schematic diagram (fig. 8) shows the various switch sections used, and the contacts made, to test a type 5Y3WGTA electron tube. Refer to the simplified circuit (fig. 9) for the operation of the circuit (d below).

d. When the polarity of the applied voltage is such that terminal 34 is positive with respect to terminal 19, current flow will be as follows:

- (1) Filament current will flow from terminal 19 of transformer T101 to the junction of R110 and pin 8 of the 5Y3WGTA under test. The current will divide at this point. Some of the current will flow through R110; the remainder of the current will flow through the filament-cathode of the tube to the other side of R110. The total filament current will return to terminal 27 of the transformer.
- (2) When pushbutton switch S110-7 is depressed and an ac voltage is applied between the plate and the cathode of the tube, plate current will flow from the cathode to the plate (pin 4) and through current limiting resistor R103 to pushbutton switch S110-7, where the current will divide. Some of the

current will flow through R112; the remainder of the current will flow to the slider arm of R127A, where the current will divide again. Some of the current will flow through resistor R127A to the junction of R127A and R127B; the remainder of the current will flow through the small resistance between the slider arm and the other end of R127A, and through C103 and M101. The meter pointer will indicate the efficiency of electron emission of the tube. The current from C103 and M101 will combine with the current from R112, and will flow through R127B to the junction of R127B and R127A. The total current in the circuit will flow through load resistor R106 to terminal 34 of T101.

- (3) When terminal 34 of T101 is negative with respect to terminal 19, filament current will flow from terminal 27 to the junction of R110 and pin 2 of the 5Y3WGTA under test. The current will divide at this point. Some of the current will flow through R110; the remainder of the current will flow through the filament-cathode of the tube to the other side of R110. The total filament current will return to terminal 19 of the transformer.

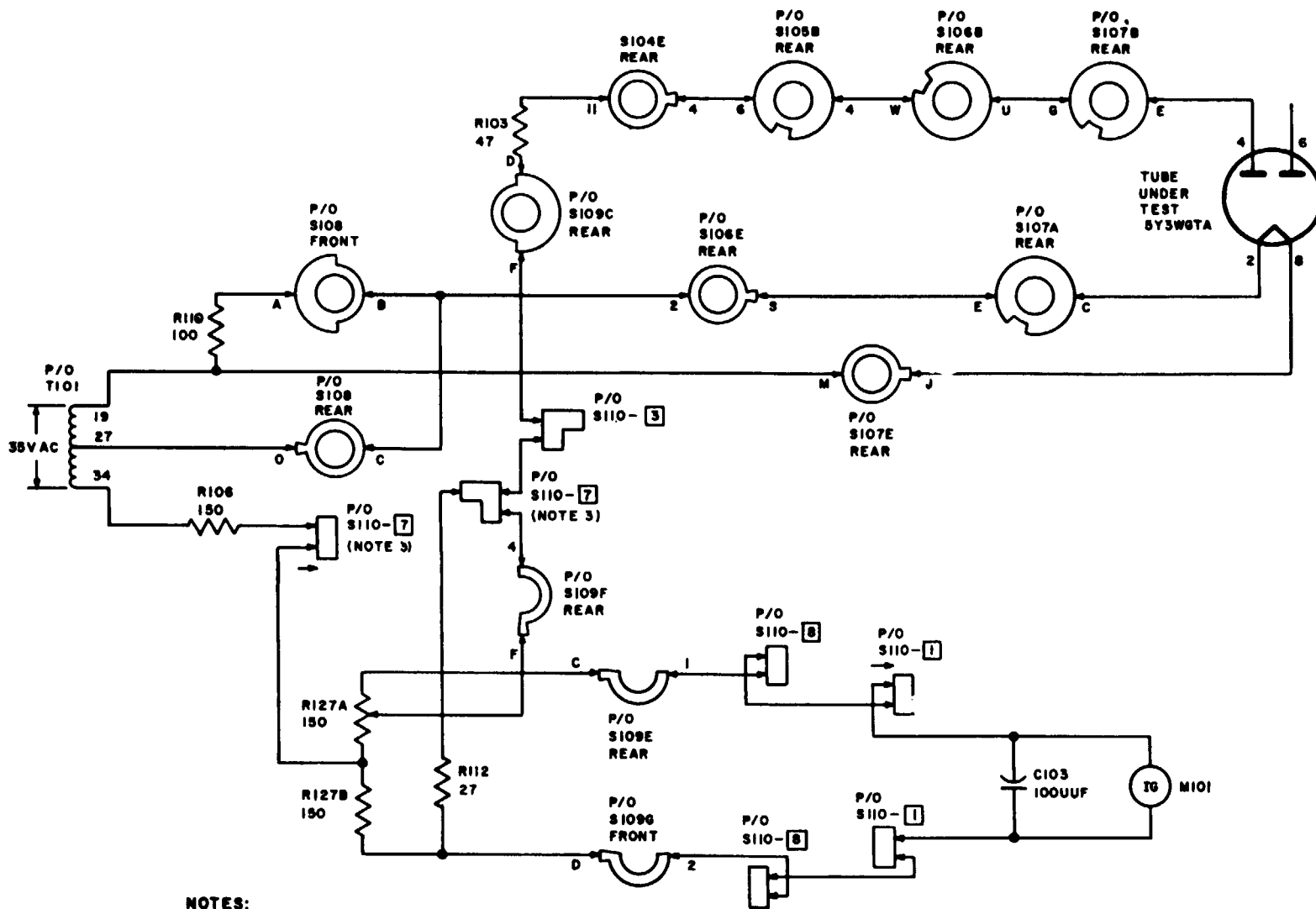

NOTES:

1. RESISTANCES ARE IN OHMS.
2. SWITCH CONTACTS MADE WILL VARY WITH THE TYPE OF TUBE UNDER TEST.
3. SWITCH S110-7 IS SHOWN DEPRESSED.
4. DENOTES EQUIPMENT MARKING.

Figure 8. Rectifier test circuit, TV-7D/U, partial schematic diagram.

(4) When terminal 34 of T101 is negative with respect to terminal 19, the plate of the tube is negative with respect to the cathode and no plate current will flow. The damping action of the meter movement results in a relatively constant meter indication even though no current is supplied by the tube under test.

e. Since the tube under test in this instance is a duodiode, each half of the tube must be tested separately. When the selector switches are reset according to the information in the tube test data book, the plate connection to pin 4 is broken and pin 6 is connected into the test circuit.

10. Mutual Conductance Test Circuit

(fig. 10, 11, and 42-44)

a. The mutual conductance (G_m) of an amplifier-type vacuum tube is an indication of the effectiveness of the tube to convert a small change in grid voltage (grid signal) to a large change in plate current. The mutual conductance of a tube is found by dividing the change in plate current (Δi_p) by the change in grid voltage (Δe_g).

b. The plate voltage for the tube under test is supplied by plate rectifier tube V101 (fig. 10 and 11). Screen and bias rectifier tube V102

supplies the screen grid voltage and the bias voltage to the tube under test for a direct measurement of mutual conductance. The bias voltage is adjusted by BIAS control R129. The signal voltage, developed across secondary No. 3 of T101, produces an ac flow through voltage divider resistors R120 through R122. The voltage across all three resistors is applied between the control grid and the cathode of the 6SK7 under test, and acts in series with the dc grid bias. The signal voltage alternately swings the grid voltage more negative or less negative, thereby producing the variable grid voltage (Δe_g) required for a dynamic test.

Note. Other electron tubes may require a smaller signal voltage. When this is the case, switching circuits enable only R120, or R120 and R121, to be connected into the test circuit.

c. The mutual conductance test circuit is actuated by pushbutton switch S110-3 (3 — MUT. COND.). The normal screen grid voltage of +130 volts dc is excessive for testing certain tubes such as the 1R5. In such cases, it is necessary to hold down pushbutton switch S110-2 (2 — DIODE) before pushbutton switch S110-3 is depressed. This action breaks the connection between the screen grid of the tube under test and contact A of resistor R130, and connects the screen grid to contact B of R130, which is at a potential of approximately +56 volts dc.

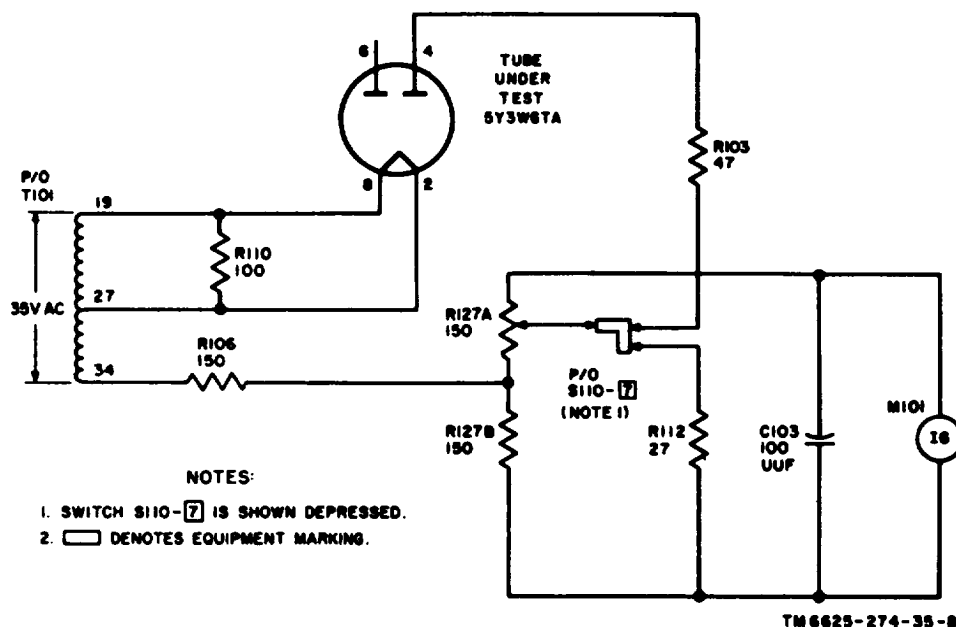
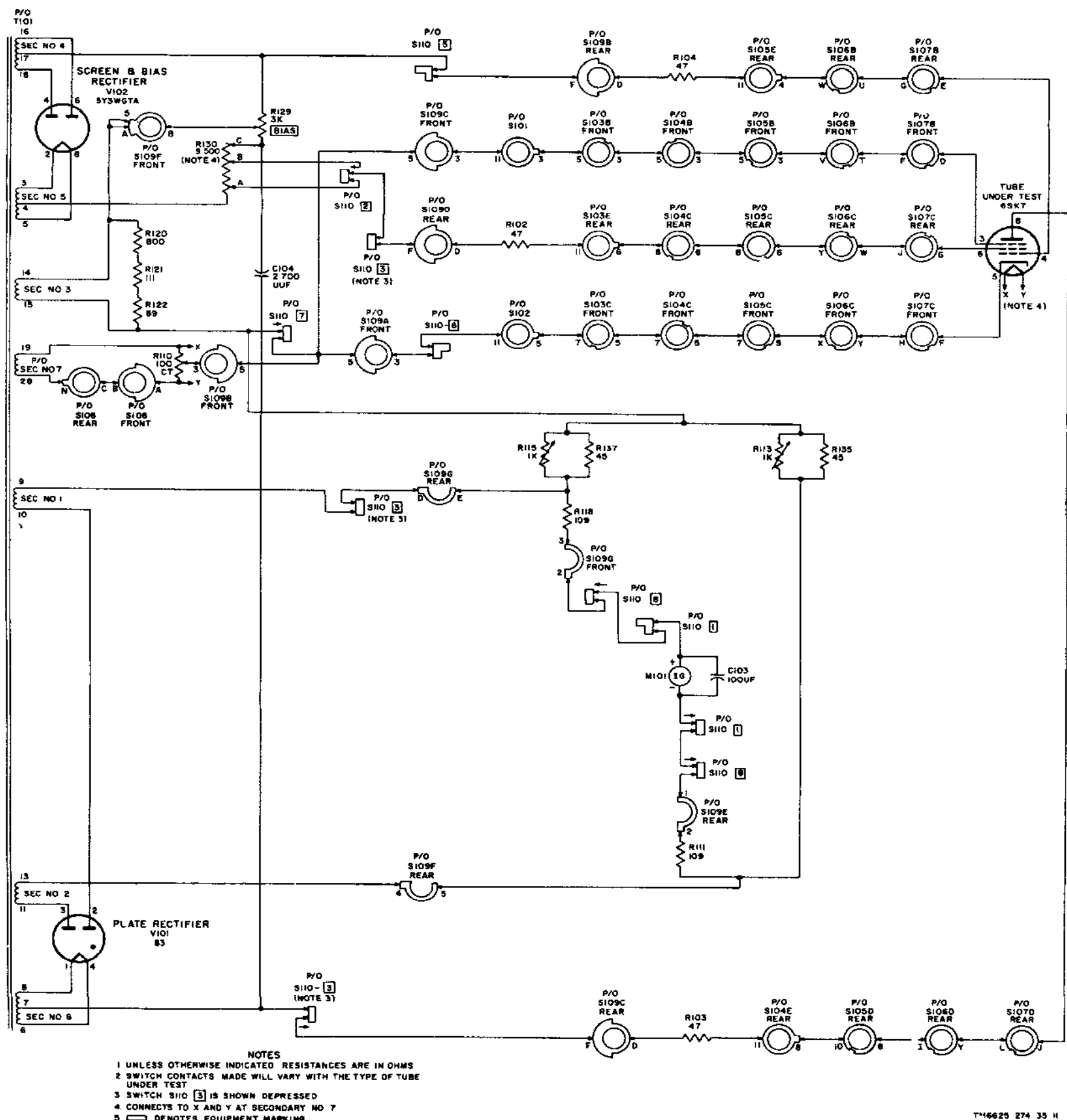

Figure 9. Simplified rectifier test circuit, TV-7D/U.

Figure 10. Mutual conductance test circuit, TV-7D/U, partial schematic diagram



d. The partial schematic diagram (fig. 10) shows the various switch sections used and the Contacts made to test a type 6SK7 electron tube. Refer to the simplified circuit (fig. 11) for the operation of the circuit (e below).

e. When pushbutton switch S110-3 is depressed, a voltage of approximately +150 volts dc is applied to the plate of the tube under

- (1) When the polarity of the voltage across secondary No. 2 of T101 is such that pin 3 of V101 is positive with respect to the cathode of V101, the signal voltage applied between the control grid and the cathode of the tube under test will swing in a positive direction, thereby decreasing the bias and increasing the current flow through the circuit. The increasing current will flow from the cathode to the plate of the 6SK7, through R103, a neutralizing resistor, to the cathode of V101. Current will flow from the cathode of V101 to pin 3 and through secondary No. 2 of T101 to the junction of R111 and R135 in parallel. Current will divide at this point. Some current will flow through R113 and R135 to the cathode of the tube under test; the remainder of the current will flow through R111, M101 and C103 in parallel, R118, and R115 and R137 in parallel, to the cathode of the tube under test. The screen grid will draw some current since it is positive with respect to the cathode. The screen grid current will flow through R102, which is used to suppress oscillations that may be produced by the tube under test, to V102, and back to the cathode of the tube. Resistor R104, in the control grid circuit, is also used to suppress oscillations that may be produced by the tube under test.
- (2) When the polarity of the voltage across secondary No. 1 of T101 is such that pin 2 of V101 is positive with respect to the cathode of V101, the signal voltage applied to the tube under test will swing in a negative direction, thereby increasing the bias and decreasing the current flow

through the circuit. The decreasing current will flow from the cathode to the plate of the 6SK7 and through R103 to the cathode of V101. Current will flow from the cathode of V101 to pin 2, and through secondary No. 1 of T101 to the junction of R118 and R115 and R137 in parallel. Current will divide at this point. Some current will flow through R115 and R137 to the cathode of the tube under test; the remainder of the current will flow through R118, M101 and C103 in parallel, R111, and R113 and R135 in parallel, to the cathode of the tube under test.

- (3) With unbalanced currents flowing through M101 on adjacent half cycles, and unequal forces applied to the meter pointer, the deflection of the pointer will be proportional to the difference between the two currents. The heavier current flow through M101 occurs when pin 3 of V101 is positive with respect to the cathode of V101, and results in an essentially steady, upscale reading on the meter,

11. Gas Test Circuit

(fig. 12)

a. The plate voltage for the tube under test is supplied by secondary No. 2, terminals 11 and 13, of T101. Screen and bias rectifier tube V102 supplies the bias voltage. Since there is no screen grid in the tube under test in this instance, no connection is made to the screen grid voltage supply.

b. When pushbutton switch S110-4 (4 — GAS 1) is depressed, a definite value of plate voltage and bias voltage is applied to the tube under test and causes a definite value of plate current to flow. Meter M101 is in the plate-to-cathode circuit of the tube under test and will be actuated by the plate current.

c. When pushbutton switch S110-5 (5 — GAS 2) is depressed, grid resistor R128, which was shorted by part of switch S110-5, is inserted into the control grid circuit. If grid current flows from the bias voltage source through the grid circuit to the cathode as shown by the arrows, due to gas in the tube, the grid current will develop a voltage drop across R128 in the direction indicated. A

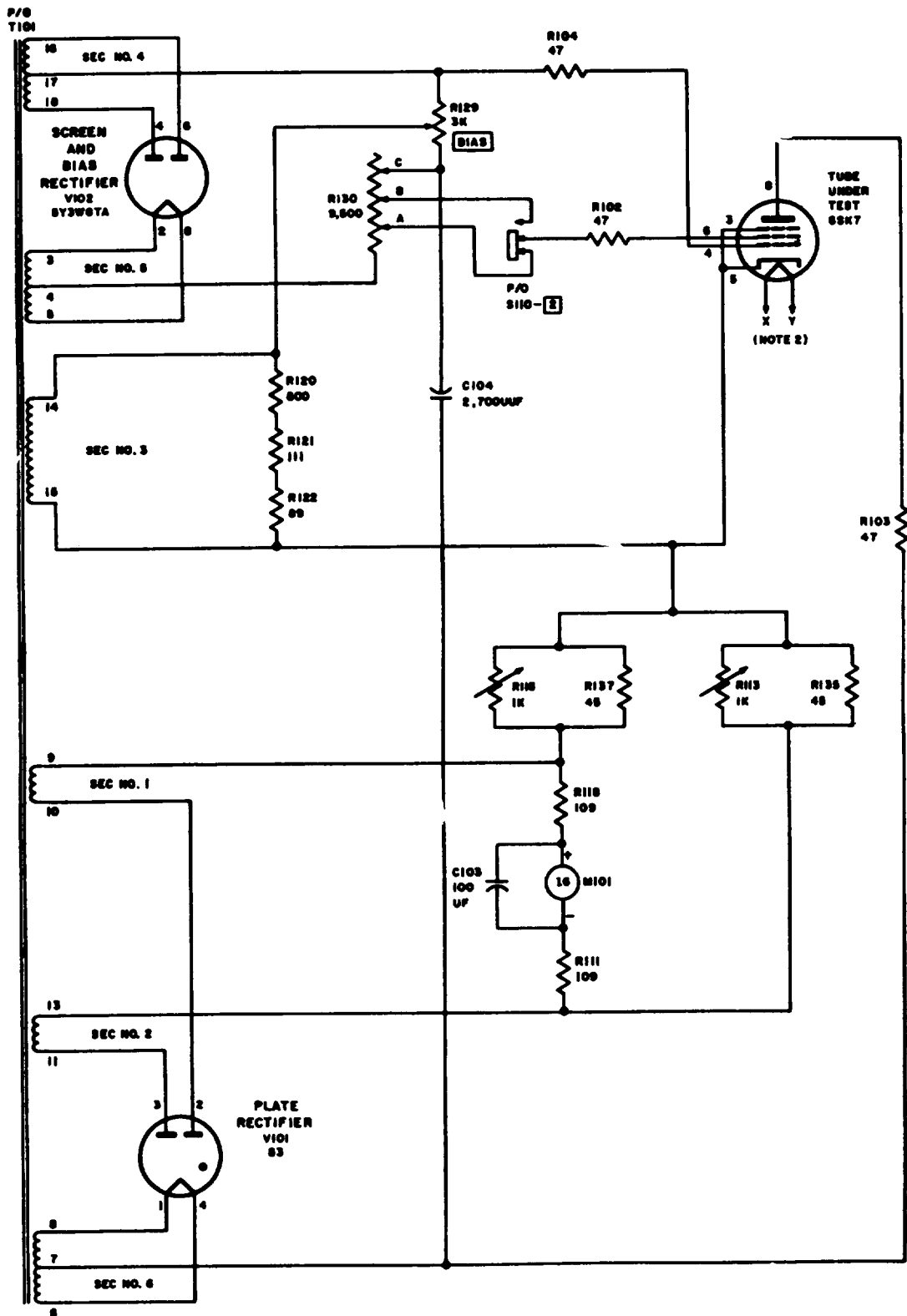

NOTES:
 1. UNLESS OTHERWISE INDICATED, RESISTANCES ARE IN OHMS.
 2. CONNECTS TO FILAMENT CIRCUIT.
 3.  DENOTES EQUIPMENT MARKING.

TM6629-274-38-10

Figure 11. Simplified mutual conductance test circuit, TV-7D/U.

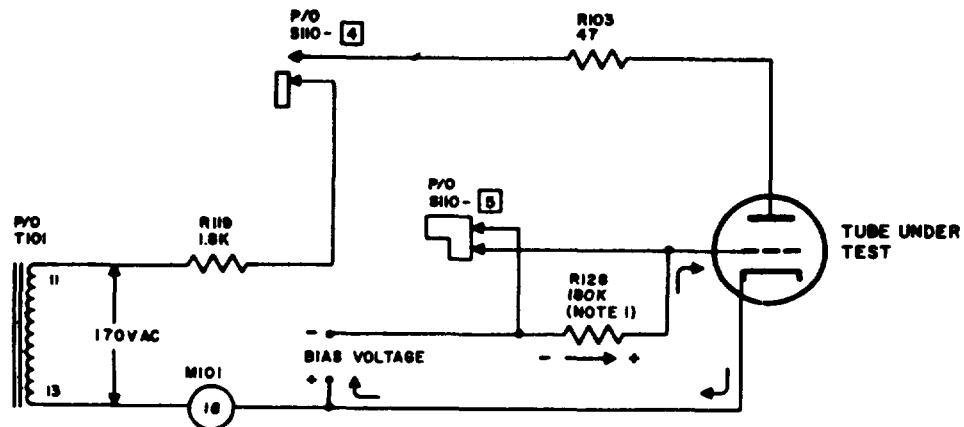

- NOTES:**
- 1 RESISTOR R141 IS CONNECTED IN PARALLEL WITH RESISTOR R128 FOR THE F RANGE GAS TEST.
 - 2 □ DENOTES EQUIPMENT MARKING.

TM6625-274-36-12

Figure 12. Simplified gas test circuit.

voltage drop across R128 will reduce the negative bias on the grid of the tube, and will cause the plate current to increase. The increased plate current must flow through M101 and will cause the meter reading to increase. The increased meter reading should not exceed one scale division.

Note. In the TV-7D/U, resistor R141 is connected parallel to R128 for gas tests when the RANGES F position of the FUNCTION SWITCH is used.

12. Special Switching Circuits

(fig. 13 and 14)

a. Selector Switches.

- (1) The selector switches, FILAMENT (S107 and S106), GRID (S105), PLATE (S104), SCREEN (S103), CATHODE (S102), and SUPPRESSOR (S101) are constructed and interconnected so as to eliminate the possibility of applying more than one voltage to any tube pin at the same time, or of creating a shorted condition by accidental disturbance of the switches. The basic principle of this interlocking circuit is shown in figure 13.
- (2) Conductors from test socket contacts 1 through 9 enter the switching circuit from the left and progress toward the right through the FILAMENT, GRID, PLATE, SCREEN, CATHODE, and SUPPRESSOR selectors. To simplify the figure, only portions

of the first four selectors have been shown.

- (a) The left FILAMENT selector is set to apply voltage to pin 1 of the test sockets. This switch setting automatically breaks the conductor from pin 1 at point A, and makes it impossible for any other voltage to reach pin 1 regardless of where the succeeding selectors are set.
- (b) The right FILAMENT selector is set to apply voltage to pin 2. The conductor is broken from this pin at point B, and no other voltage can reach pin 2.
- (c) When the GRID selector is set to deliver grid voltage to pin 3, the conductor is broken from this pin at point C and the application of any other voltage to pin 3 is prevented.
- (d) Setting the PLATE selector to deliver plate voltage to pin 4 breaks the conductor from pin 4 at point D.
- (e) If the first four selectors are set in this manner, filament voltage is applied across pins 1 and 2, grid voltage to pin 3, and plate voltage to pin 4, but application of any other voltage to these pins is impossible.

b. Shorts Test Switch. The operation of the SHORTS portion of FUNCTION SWITCH

S109 (fig. 14) shows the shorts test section of the switch in position 1. In this position, the cathode, the filament, and the suppressor grid of the tube under test are in contact with segment Y; the screen grid, the plate, and the control grid are in contact with segment Z. Any shorted condition between an element on segment Y and elements on segment Z completes the circuit between C102 and E101, and SHORTS lamp E101 will glow. Rotation of . . . switch from position 2 through position 5 changes the grouping of the elements on the two segments. Different types of shorts will cause the neon lamp to glow on different positions of the switch; that is, a screen-to-suppressor short will cause the lamp to glow in all five positions while a control grid-to-plate short will cause a glow only on position 4. The following chart shows the various possible inter-

element shorts within a tube and the positions of the FUNCTION SWITCH in which the SHORTS lamp will glow for a particular short:

Kind of short	FUNCTION SWITCH position				
	1	2	3	4	5
Screen to suppressor	X	X	X	X	X
Control grid to cathode	X	X	X		X
Filament to plate	X	X		X	X
Filament to control grid	X	X			X
Filament to screen	X		X	X	X
Plate to suppressor	X			X	X
Control grid to suppressor	X				X
Control grid to screen		X	X	X	
Plate to screen		X	X		
Filament to suppressor		X			
Filament to cathode			X		
Control grid to plate				X	

Note. Multisection tubes must be tested for shorts by individual sections. Data in the shorts test chart above apply to the elements of the sections of these tubes.

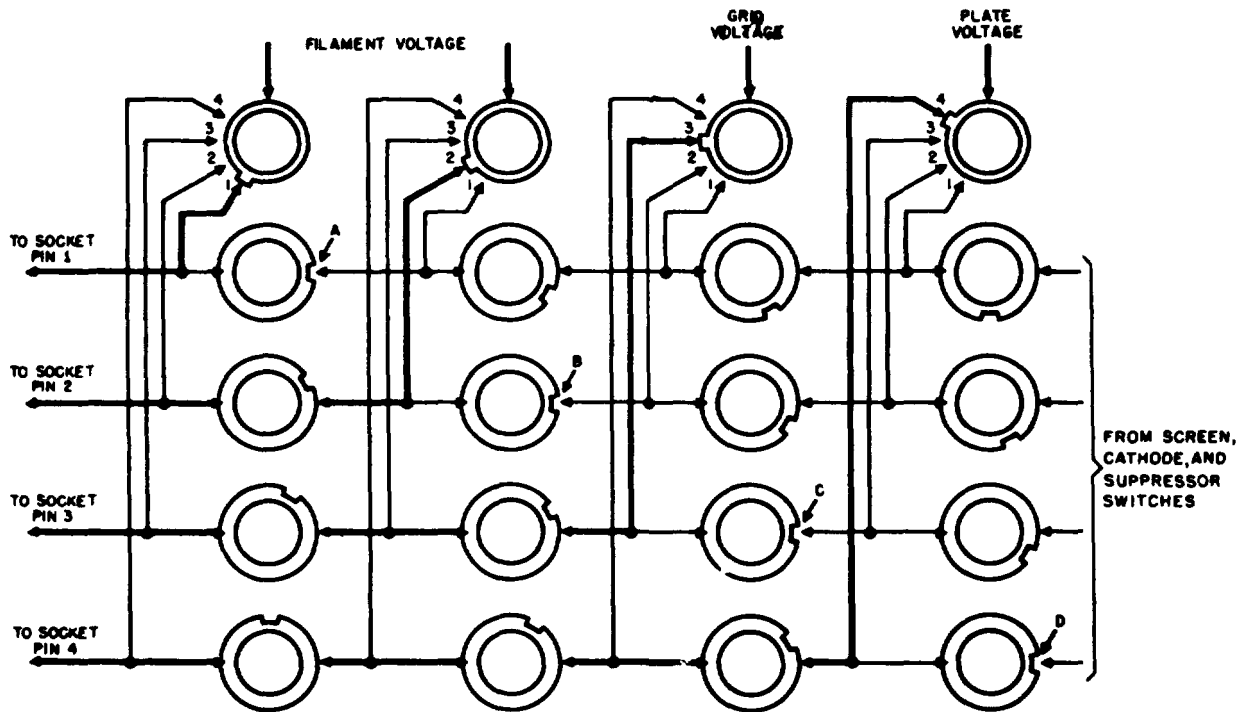

NOTES:
 1. CONNECTIONS FOR PINS 5 THRU 9 AND ASSOCIATED SWITCH SECTIONS ARE NOT SHOWN.
 2. HEAVY LINES INDICATE CURRENT FLOW.

TM6625-274-35-14

Figure 13. Simplified selector switch diagram.

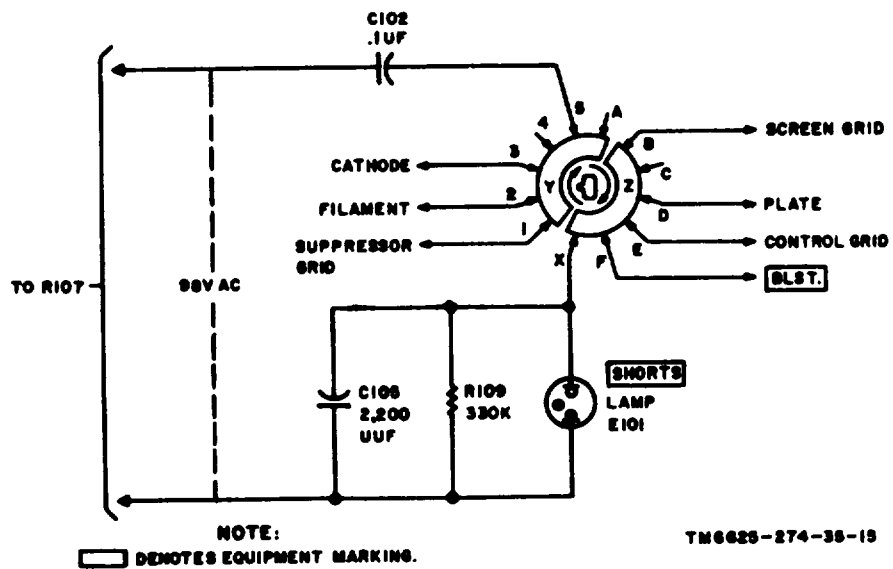

Figure 14. Simplified shorts test switch diagram.

CHAPTER 2

TROUBLESHOOTING

13. General Instructions

Troubleshooting at fourth and fifth echelon maintenance levels includes all the techniques outlined for organizational maintenance (TM 11-6625-274-12) and any special or additional techniques required to isolate a defective part. The field and depot maintenance procedures are not complete in themselves but are supplemented by the procedures described in TM 11-6625-274-12. The systematic troubleshooting procedure, which begins with the checks that can be performed at an organizational level, must be completed by means of additional localizing and isolating techniques.

14. Troubleshooting Procedures

a. *General.* The first step in servicing a defective test set is to localize the fault to the circuit responsible for abnormal operation. The second step is to isolate the fault to the defective part that is responsible for the abnormal condition. Some faults, such as a burned-out resistor, can often be located by sight or smell. The majority of faults, however, must be localized by checking resistances.

b. *Localization.* The test set can be used to check pilot lamps, diode tubes, amplifier tubes for G_m , gas, and noise, and to check tubes for shorts. The first step in localizing troubles is to determine the circuit or circuits at fault by the following methods:

- (1) Visual inspection. The purpose of visual inspection is to locate faults without testing or measuring circuits. All meter readings and other visual signs should be observed to try to localize the fault to a particular circuit.
- (2) Operational tests. Operational tests frequently indicate the general location of trouble. In many instances, the tests will help in determining the exact nature of the fault. The equipment performance checklist (TM 11-6625-274-12) is a good operational test.

c. *Isolation.* The checks listed below will aid in isolating the trouble. After the trouble has been isolated to a particular circuit, isolate the trouble within that circuit to a particular part.

- (1) Resistance measurements. Use the schematic diagram (fig. 42-44) to find the value of the components. Use resistance measurements (para 17 and fig. 33 and 34) to find the value for normal readings, and compare them with the readings taken.
- (2) *Troubleshooting chart.* The symptoms listed in the troubleshooting chart (para 16) will aid in localizing trouble to a component part.
- (3) Intermittent troubles. In all these tests, the possibility of intermittent troubles should not be overlooked. If present, this type of trouble may often be made to appear by tapping or jarring the equipment. Check the wiring and connections to the test set.

15. Tools and Test Equipment Required

The following chart lists the tools and test equipment required for troubleshooting the test set, the associated technical manuals, and the assigned common names.

Tool or test equipment	Technical manual	Common name
Tool equipment TE-113		Tool equipment
Multimeter TS-352/U	TM 11-5527	Multimeter
Test Set, Elec- tron Tube TV-7(*)/U	TM 11-6625-274-12	Test set

16. Isolating Troubles

a. *General.* In the troubleshooting chart (c below), procedures are outlined for isolating troubles to a particular component part. The adjustment chart (d below) indicates the test that is to be performed when certain component parts are adjusted or replaced. Parts locations for the different models of the test set are shown in figures 15 through 32. Re-

sistance values are indicated on the schematic diagrams (fig. 42-44). Depending on the nature of the operational symptoms, one or more of the isolating procedures will be necessary,

b. *Use of Chart.* The troubleshooting chart is designed to supplement operational checks which can be performed at an organizational level. If previous operational checks have re-

sulted in reference to a particular item of the chart, go directly to the referenced item. If no operational symptoms are known, begin with item 1 of the equipment performance checklist (TM 11-6625-274-12) and proceed until a symptom of trouble appears.

c. *Troubleshooting Chart.*

Step	Symptom	Probable trouble	Correction
1	Meter pointer deflects beyond full scale when POWER switch is set to ON.	C104 shorted	Replace C104.
2	PILOT lamp does not light when POWER switch is set to ON.	Defective PILOT lamp or lamp loose in socket. Open conductor in ac line cord, open FUSE lamp E103, R126, T101 primary, or defective switch S111.	Tighten lamp in socket. Check continuity if lamp does not light. Set POWER switch to ON and connect ohmmeter between prongs of ac line cord plug. If meter indicates zero, check R126, FUSE lamp E108, switch S111, T101 primary, and each conductor in the ac line cord. Replace as necessary.
3	Meter pointer will not adjust to LINE TEST mark.	Open secondary No. 7 of T101. R123 or R125 open Defective transformer T101 Defective rectifier CR101 Defective meter M101	Check for continuity between terminals 22 and 28 of T101. Replace T101 if necessary. Replace R123 or R125. Check resistance of T101 (para 17). Replace T101 if necessary. Replace CR101. Check meter and replace if necessary.
4	No meter indication when performing line adjustment check.	Rectifier CR101 or C103 shorted. R124, R134, (TV-7B/U and TV-7D/U), or secondary No. 7 of T101 open. Pushbutton switch S110-1 contacts not making properly.	Check and replace shorted component. Replace R124, R134, or T101. Depress pushbutton 1—LINE ADJ. several times. Clean switch contacts. Replace switch S110 if necessary.
5	SHORTS lamp does not light when checking shorts test circuit (para 17e, TM 11-6626-274-12).	R108 or C102 open, or C105 shorted. Secondary No. 2 of T101 open. Defective selector switch contact.	Replace R108, C102, or C105. Check and replace if necessary. Rotate each selector switch knob and reset to test position.

	Symptom	Probable trouble	Correction
			Check continuity through the appropriate section of each switch.
6	Meter pointer will not adjust to 10 or to 100 when BIAS control is varied for gas test (TM 11-6625-274-12).	R104 open.....	Replace R104.
7	Meter does not indicate when pushbutton 2—DIODE is depressed (diode tests only).	R103, R117, R127B, R127A, at end opposite R127A, B junction, or secondary No. 7 of T101 open. Defective selector switch contact.	Replace R103, R117, R127A, or R127B. Check T101; replace if necessary. Rotate each selector switch knob and reset to test position. Check continuity through the appropriate section of each switch. Adjust defective contact; replace switch if necessary.
8	Meter reading beyond full scale when pushbutton 3-MUT. COND. is depressed.	R113, R134, (TV-7A/U, serial No. 1201-9492), R135 (TV-7B/U, TV-7D/U) open.	Replace R113, R134 (TV-7A/U, serial No. 1201-9492), or R135 (TV-7B/U, TV-7D/U).
9	Meter does not indicate when pushbutton 3—MUT. COND. is depressed.	R103, R111, R115 (TV-7/U, TV-7A/U, serial No. 1-1200), or R118 open. Open secondary No. 2, 3, or 6 of T101. Defective V101 Defective selector switch contact.	Replace defective resistor. Check T101; replace if necessary. Replace V101. Rotate each selector switch knob and reset to test position. Check continuity through the appropriate section of each switch. Adjust defective contact; replace switch if necessary.
10	Meter pointer deflects to left, off scale, when pushbutton 3-MUT. COND. is depressed.	R115, R135 (TV-7A/U, serial numbers 1201-9492), R137 (TV-7B/U, TV-7D/U) open.	Replace defective resistor.
11	Meter does not indicate when pushbutton 4-GAS 1 is depressed.	R103, R111, R115, R118, or R119 open. Open secondary No. 2 or 6 of T101. Defective V101	Replace defective resistor. Check T101; replace if necessary, Replace V101.

Step	Symptom	Probable trouble	Correction
		Defective selector switch contact.	Rotate each selector switch knob and reset to test position. Check continuity through the appropriate section of each switch. Adjust defective contact; replace switch if necessary.
12	Meter reading beyond full scale when pushbutton 4—GAS 1 is depressed.	R113, R134, (TV-7A/U, serial numbers 1201-9492), R135 (TV-7B/U, TV-7D/U) open.	Replace defective resistor.
13	Meter reading increases several units when pushbutton 5-GAS 2 is depressed.	R128 or R141 (TV-7D/U, F position of FUNCTION SWITCH), open.	Replace defective resistor.
14	Meter does not indicate when pushbutton 6-OZ4 is depressed.	R103, R119, R127A at end opposite R127A, B junction, or R127B open. Open secondary No. 2 or 7 of T101. Defective selector switch contact.	Replace defective resistor. Check T101; replace if necessary. Rotate each selector switch knob and reset to test position. Check continuity through the appropriate section of each switch. Adjust defective contact; replace switch if necessary.
15	Meter reading beyond full scale when pushbutton 6-OZ4 is depressed.	R112 open.....	Replace R112.
16	Meter does not indicate when pushbutton 7—RECT. is depressed.	R103, R106, R127A at end opposite R127A, R127B junction, or R127B open. Open secondary No. 7 of T101. Defective selector switch contact.	Replace defective resistor. Check T101; replace if necessary. Rotate each selector switch knob and reset to test position. Check continuity through the appropriate section of each switch. Adjust defective contact; replace switch if necessary.
17	Meter reading beyond full scale when pushbutton 7--RECT. is depressed.	R112 open.....	Replace R112.
18	Meter reading abnormally high (full scale or beyond) when testing some high-gain electron tubes.	Test circuit is oscillating.....	Redress the leads from all of the test sockets until correct reading is obtained. <i>Note.</i> This may correct the trouble of only a particular tube rather than all high-gain tubes. Several types of high-gain tubes should be tested and the test socket leads redressed until each tube tests correctly.

Step	Symptom	Probable trouble	Correction
19	No voltage at panel lamp test socket.	Open secondary No. 7 of T101 Defective switch S106, S107, or S108.	Check T101; replace if necessary. Rotate each selector switch knob and reset to test position. Check continuity through the appropriate section of each switch (fig. 42-44). Adjust defective contact; replace switch if necessary.
20	Signal voltage is zero (measured at test socket).	R104, R120, R121, or R122 open. Open secondary 3 of T101 Defective selector switch contact.	Replace defective resistor. Check T101; replace if necessary. Rotate each selector switch knob and reset to test position. Check continuity through the appropriate section of each switch (fig. 42-44). Adjust defective contact; replace switch if necessary.
21	Signal voltage is low or high (measured at test socket).	R104, R120, R121, or R122 changed value.	Check resistances; replace defective resistor.
22	Plate voltage is zero (measured at test socket).	V101 defective. R103 open Open secondary No. 6 of T101 Defective selector switch contact.	Replace V101. Replace R108. Check T101; replace if necessary. Rotate each selector switch knob and reset to test position. Check continuity through the appropriate section of each switch (fig. 42-44). Adjust defective contact; replace switch if necessary.
23	Plate voltage is low (measured at test socket).	V101 defective. Open secondary No. 1 or 2 of T101.	Replace V101. Check T101; replace if necessary.
24	Plate voltage is high (measured at test socket).	Open secondary No. 5 of T101	Check T101; replace if necessary.
25	Screen voltage is zero (measured at test socket).	V102 defective. Open secondary No. 5 of T101 R102, R133 (TV-7A/U, serial numbers 1-1200), or R129 (-) end open. Defective selector switch contact.	Replace V102. Check T101; replace if necessary. Replace defective resistor. Rotate each selector switch knob and reset to test position. Check continuity through the appropriate section of each switch (fig. 42-44). Adjust defective contact; replace switch if necessary.

Step	Symptom	Probable trouble	Correction
26	Screen voltage is low (measured at test socket).	V102 weak Open secondary No. 3 or 4 of T101.	Replace V102. Check T101; replace if necessary.
27	Screen voltage is high (measured at test socket).	R129 open at (+) end or R130 open. Open secondary No. 6 of T101 . .	Replace defective resistor. Check T101; replace if necessary.
28	Bias voltage is zero (measured at test socket).	R104, R129, R130, or R133 (TV-7A/U, serial numbers 1-1200) open. V102 defective Open secondary No. 5 of T101 Defective selector switch contact.	Replace defective resistor. Replace V102. Check T101; replace if necessary. Rotate each selector switch knob and reset to test position. Check continuity through the appropriate section of each switch (fig. 42-44).. Adjust defective contact; replace switch if necessary.
29	Bias voltage is low (measured at test socket).	V102 weak Open secondary No. 3 or 4 of T101.	Replace V102. Check T101; replace if necessary.

d. Adjustment Chart.

	Component adjusted or replaced				Test
	TV-7A/U		TV-7B/U	TV-7D/U	
	Serial numbers 1 through 1200	Serial numbers 1201 through 9492			
CR101 or R124	CR101 or R124	CR101 or R124	CR101, R124, or R134	CR101, R124, or R134	Line adjust circuit (para 23)
R129 or R130	R129, R130, or R133	R129 or R130	R129 or R130	R129 or R130	Plate (para 23) and screen grid (pare 24) voltage
R113 or R115	R113 or R115	R113 or R115	R113 or R115	R113 or R115	Simulated tube test (para 26)
R127	R127	R127	R127	R127	Shunt control (para 27)
R114	R114	R114	R114	R114 R139	RANGES C of FUNCTION SWITCH (para 28) Bias voltage (para 22)

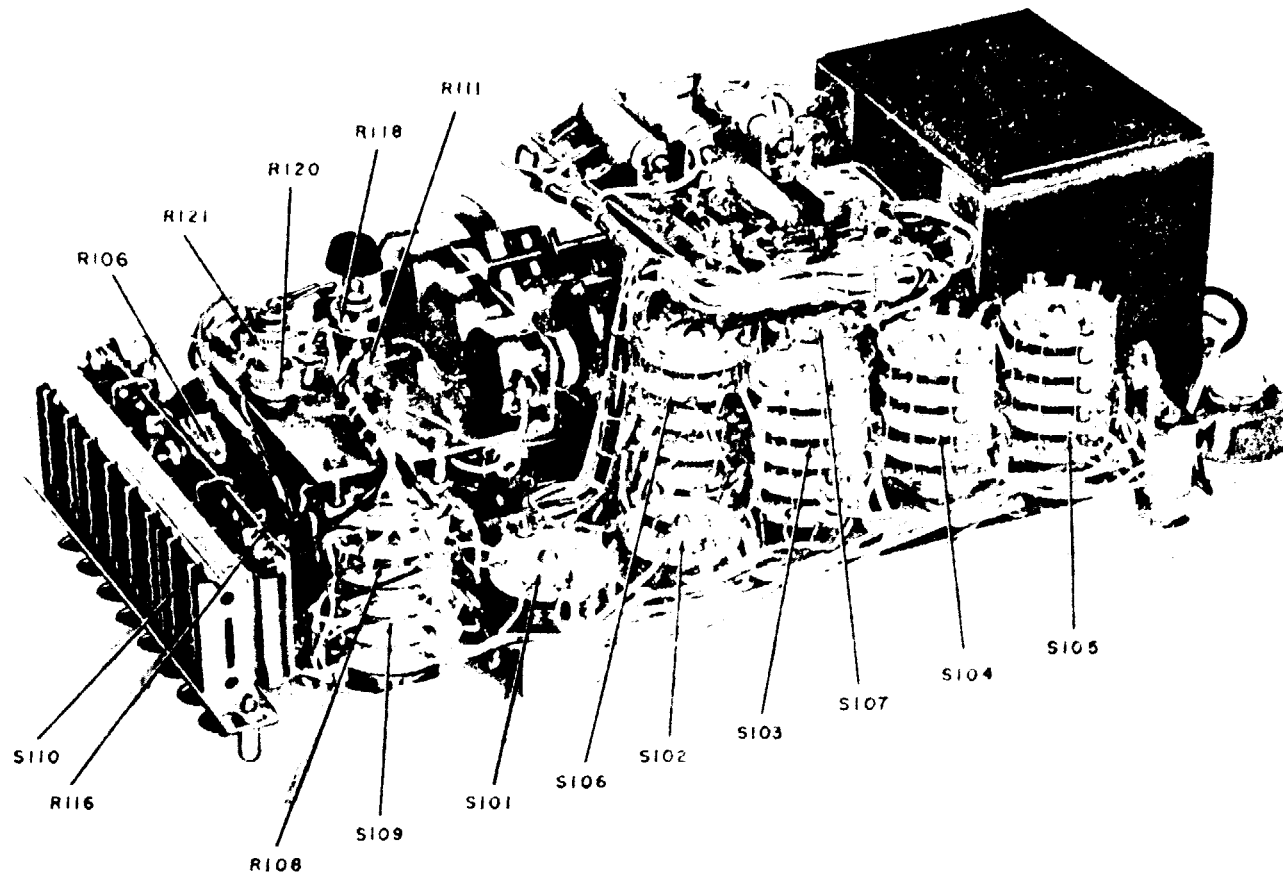

TM6625-274-35-16

Figure 15. Test Set, Electron Tube TV-7A/U (serial numbers 1 through 1200), front-left oblique.

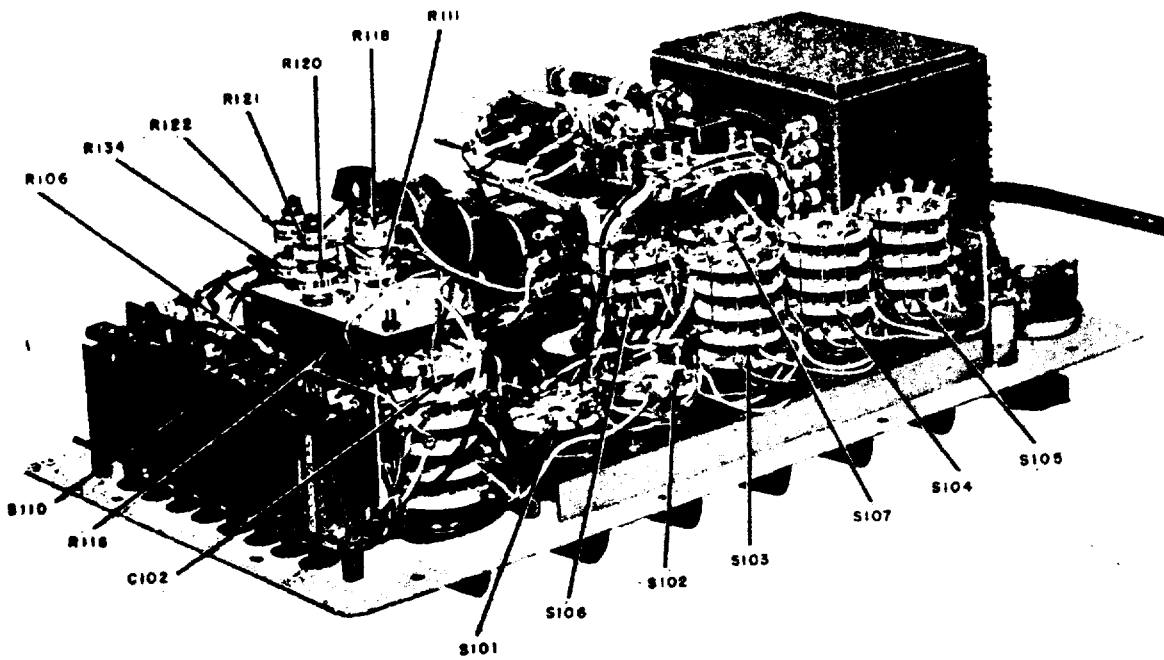

TM6625-274-35-17

Figure 16. Test Set, Electron Tube TV-7A/U (serial numbers 1201 through 9492), front-left oblique.

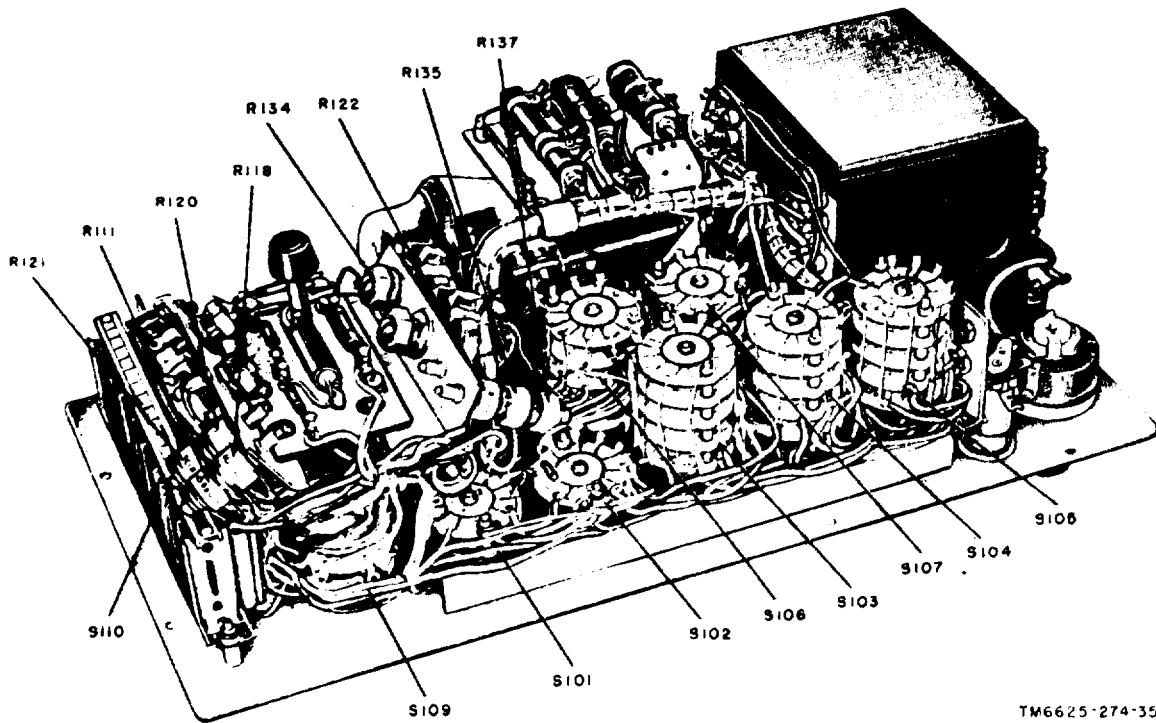

TM6625-274-35-18

Figure 17. Test Set, Electron Tube TV-7BIU, front-left oblique.

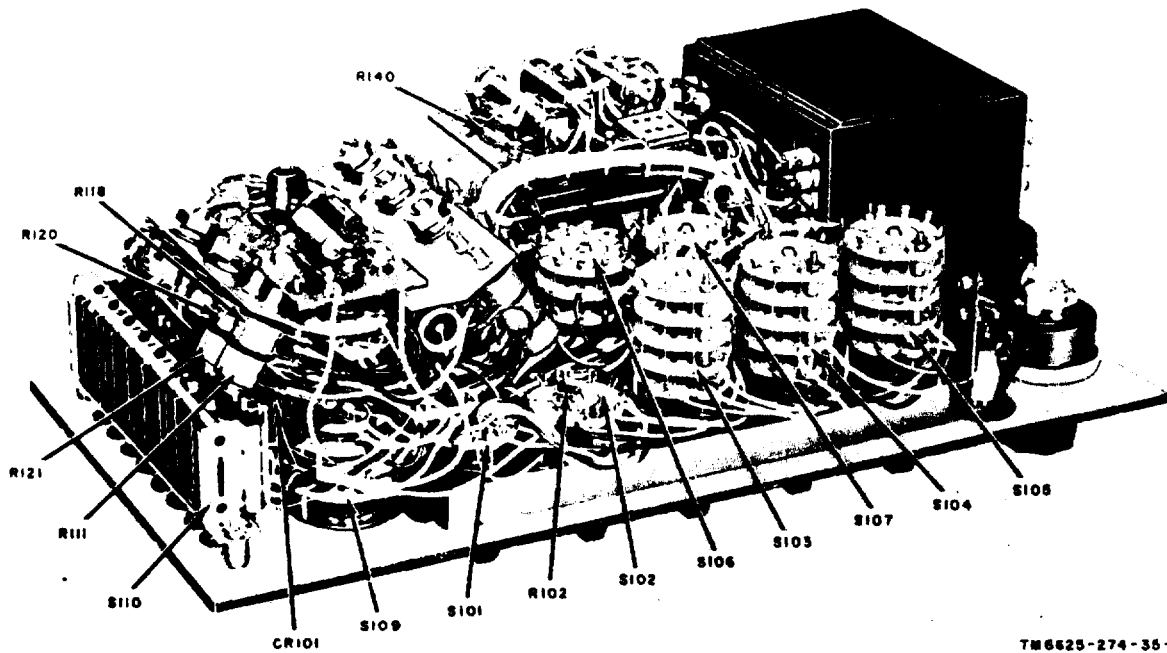

TM 6625-274-35-19

Figure 18. Test Set, Electron Tube TV-7D/U, front-left oblique.

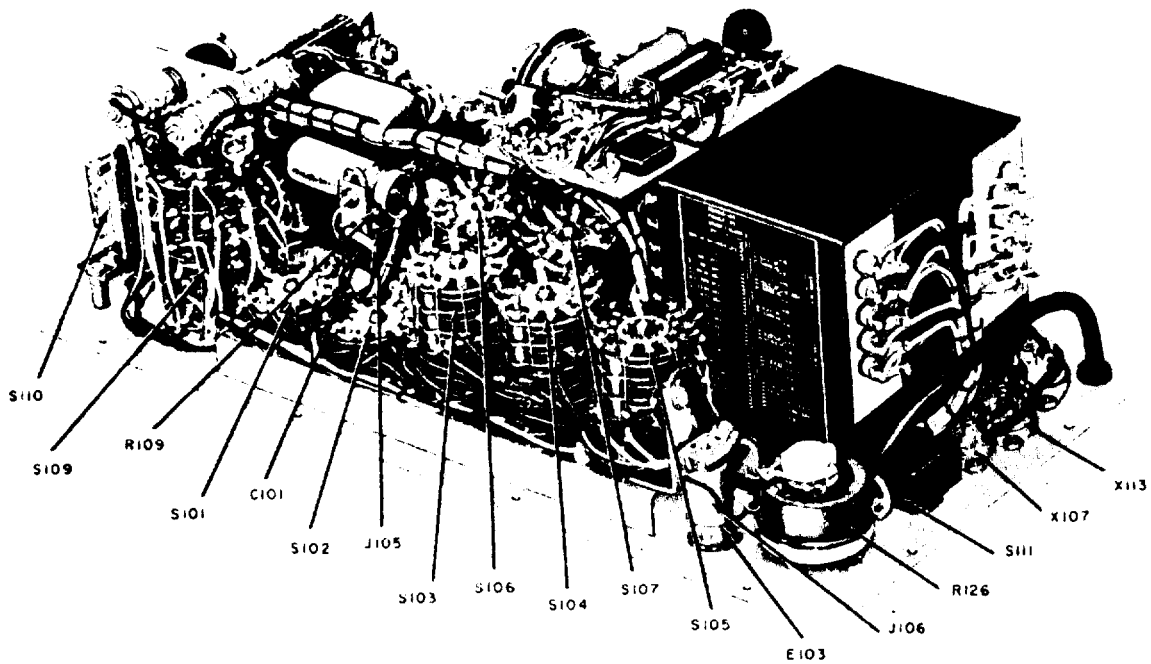
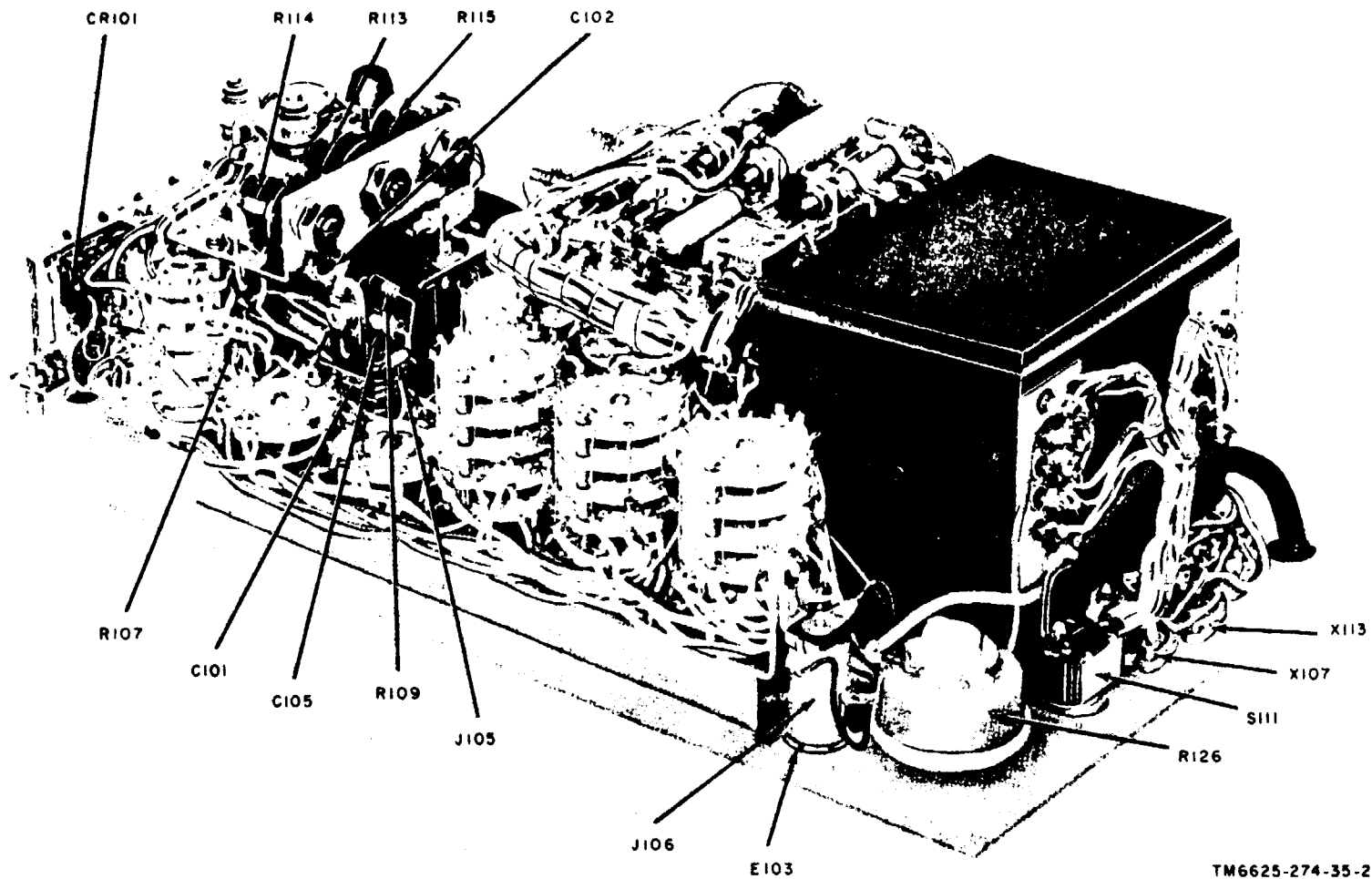
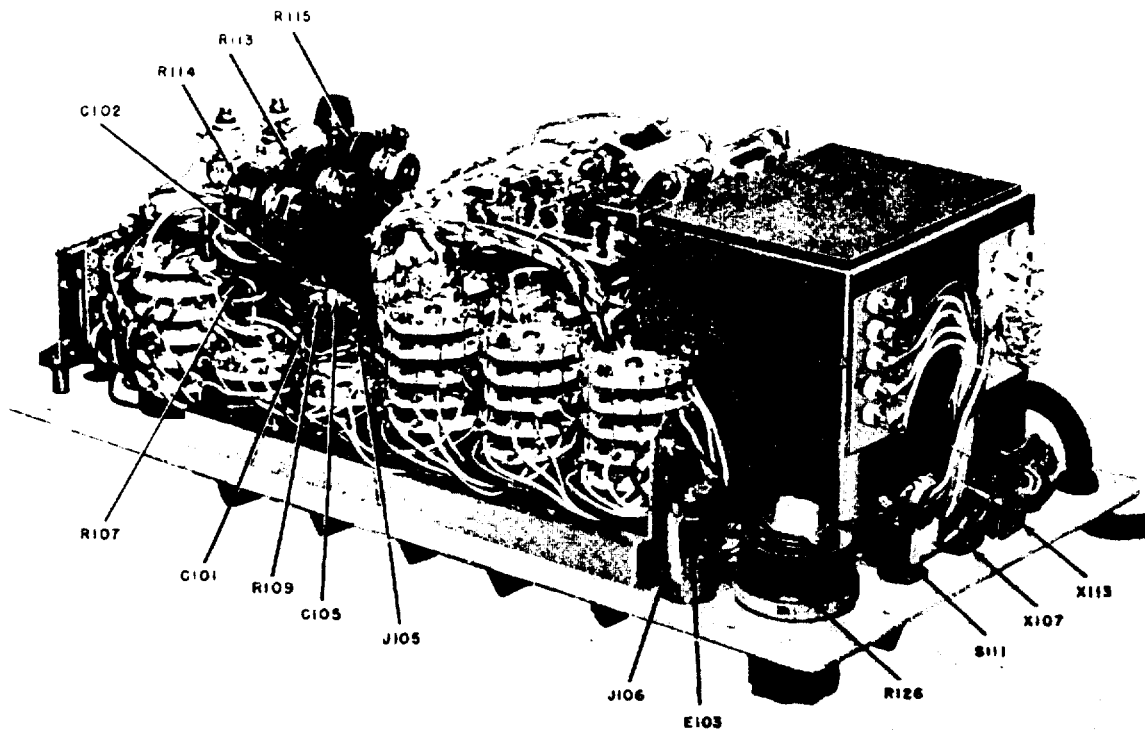

Figure 19. Test Set, Electron Tube TV-7/U, front-right oblique.



TM6625-274-35-21

Figure 20. Test Set, Electron Tube TV-7A/U (serial numbers 1 through 1200), front-right oblique.



TM6625-274-35-22

Figure 21. Test Set, Electron Tube TV-7A/U (aerial numbers 1201 through 9492), front-right oblique.

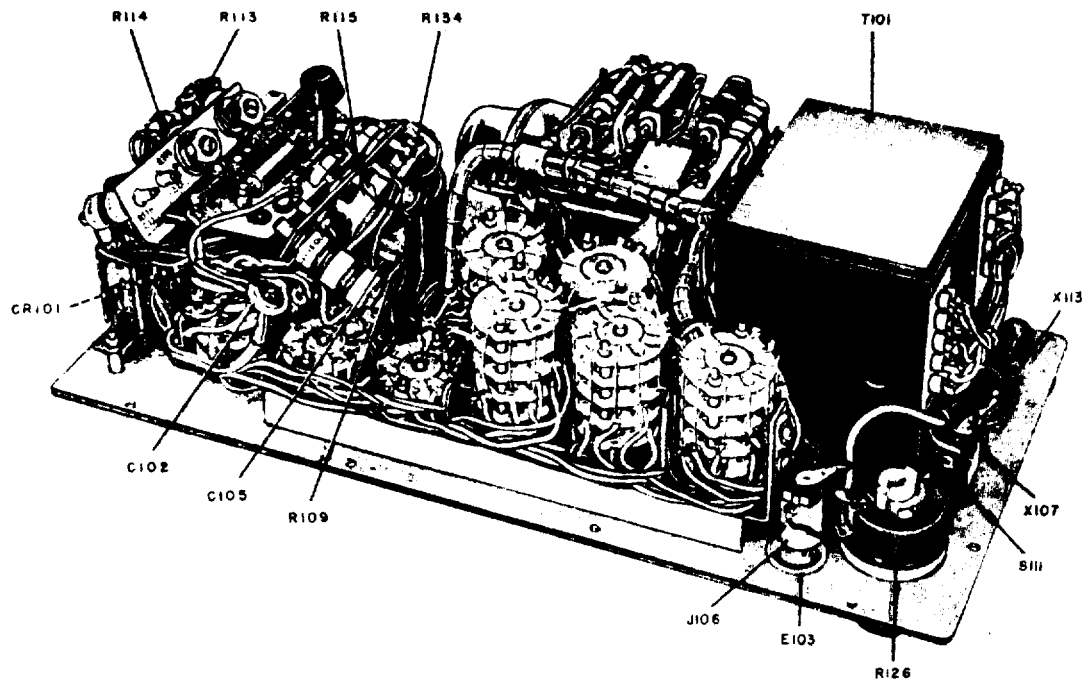

TM6625-274-35-23

Figure 22. Test Set, Electron Tube TV-7B/U, front-right oblique.

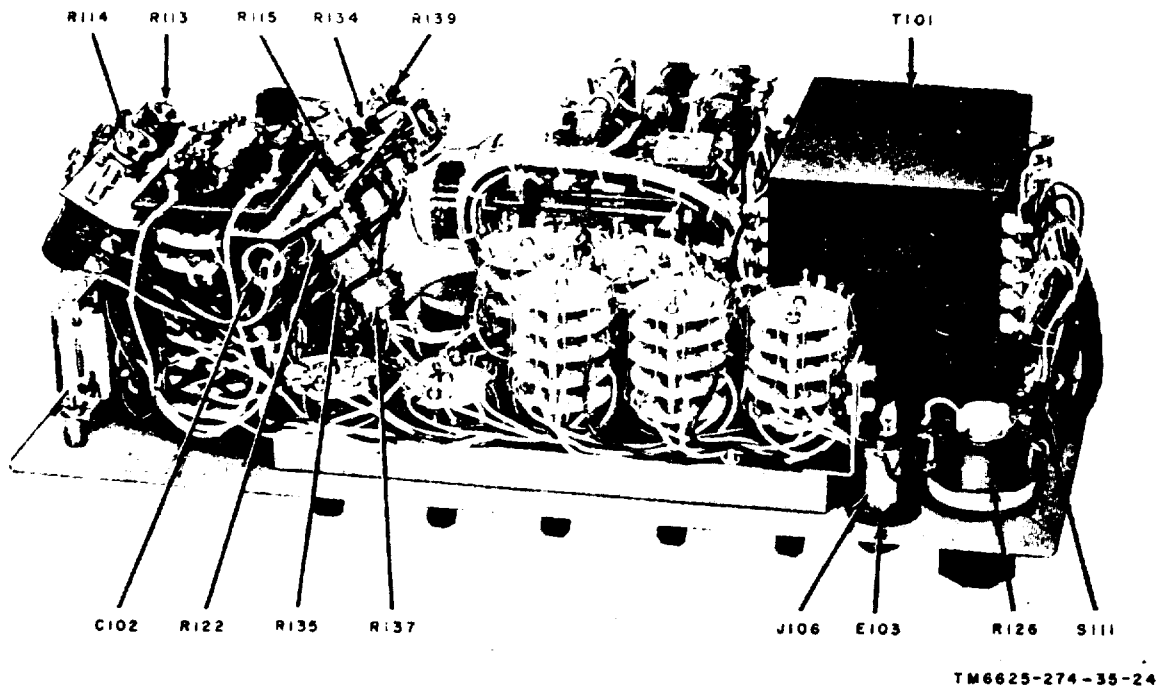

Figure 23. Test Set, Electron Tube TV-7DIU, front-right oblique.

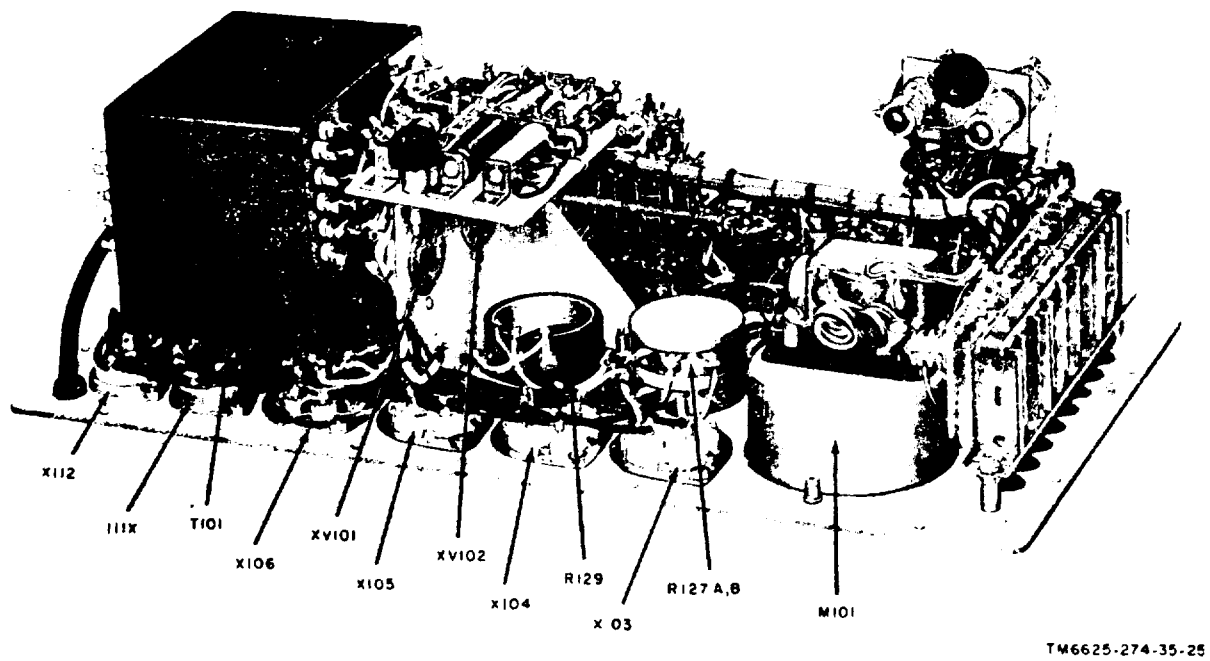

Figure 24. Test Set, Electron Tube TV-7/U, tubes removed, rear-right oblique.

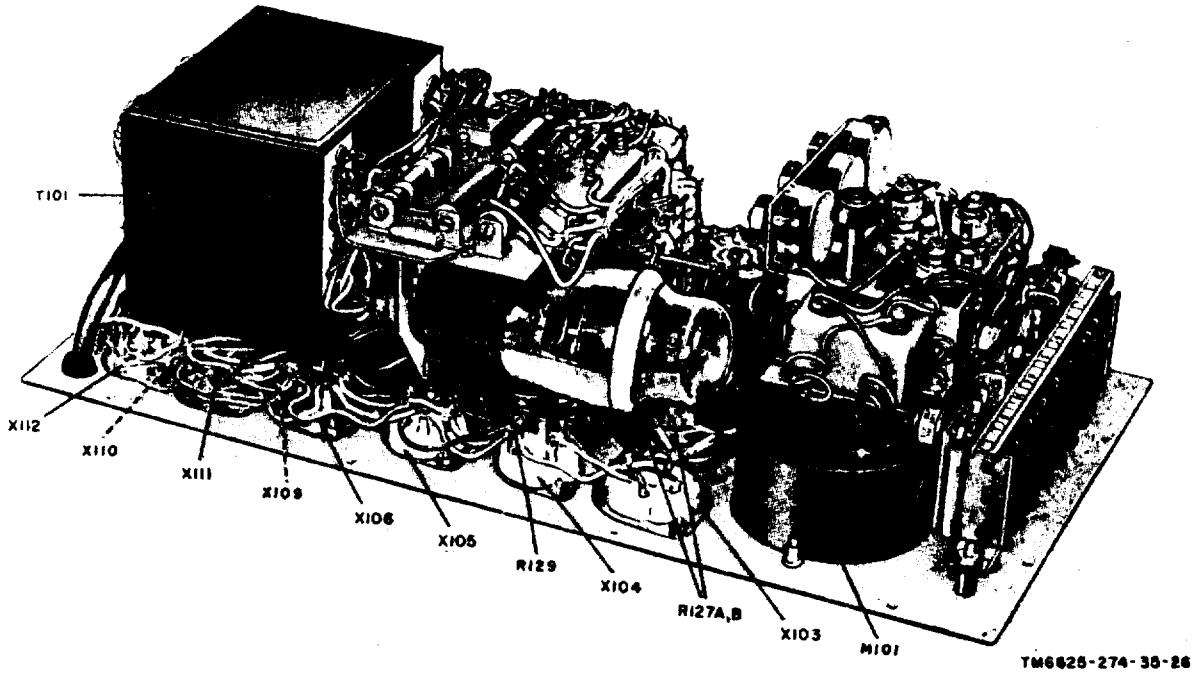

Figure 25. Test Set, Electron Tube TV-7A/U (serial numbers 1 through 1200), rear-right oblique.

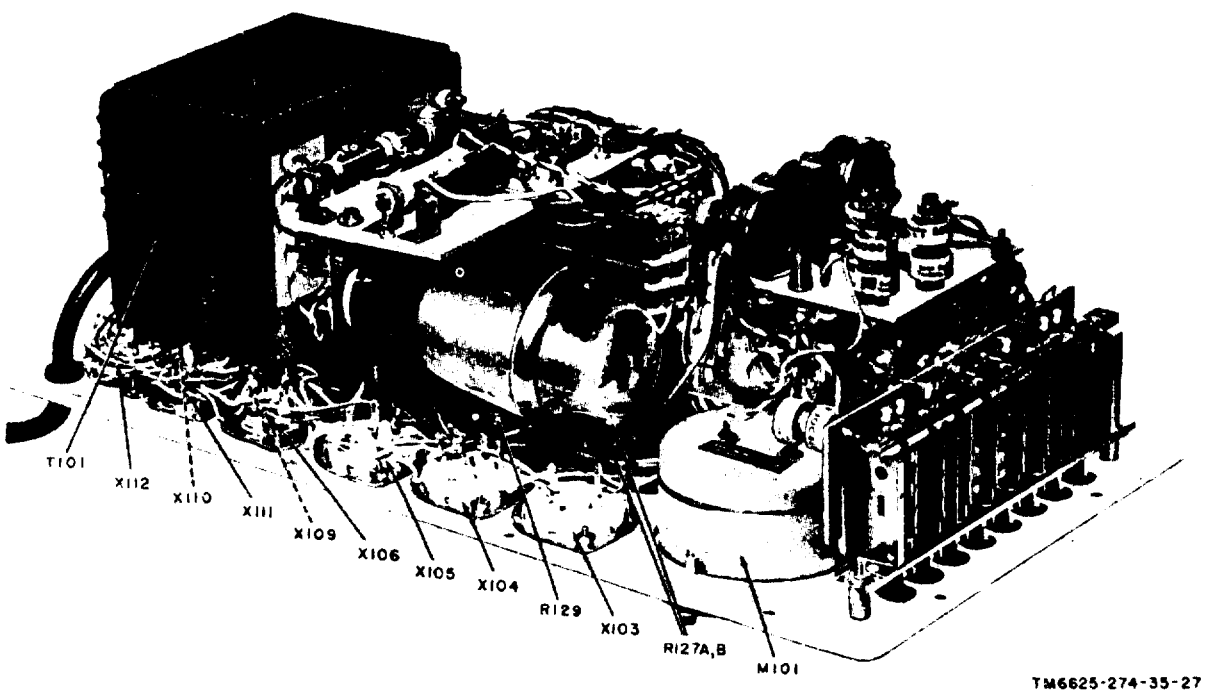
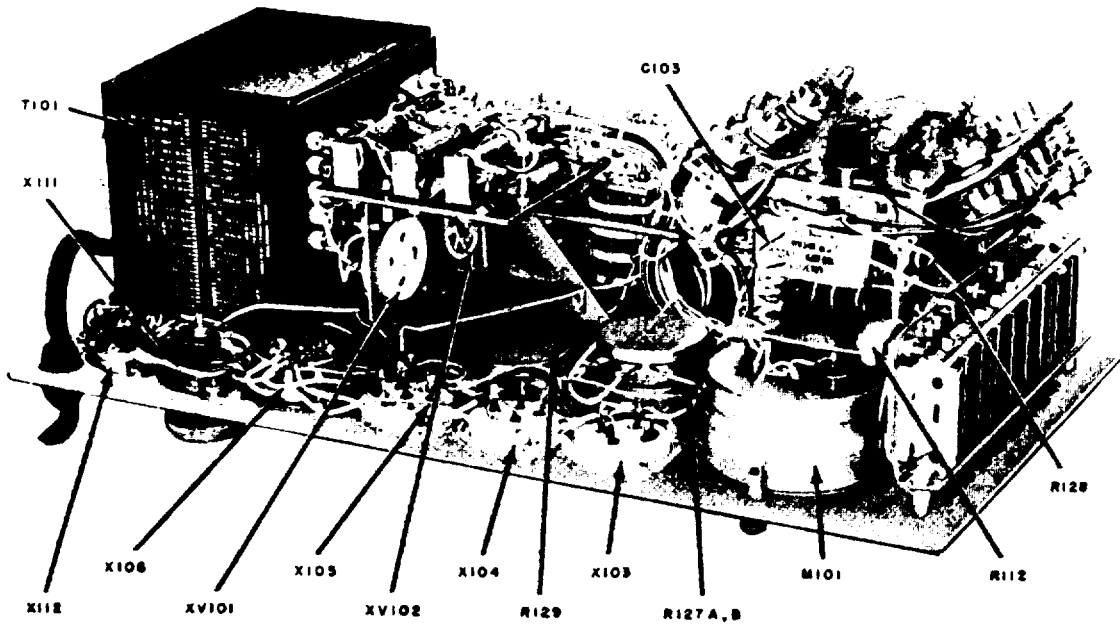
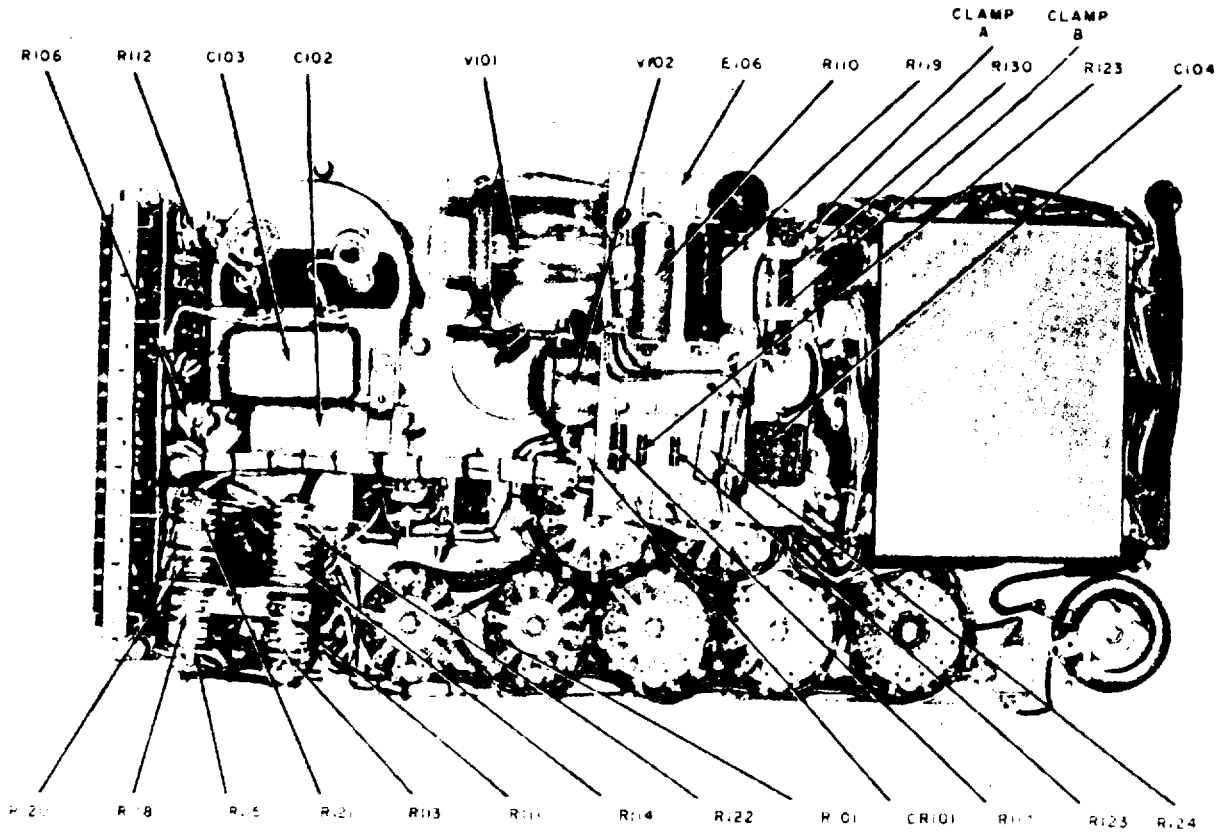

Figure 26. Test Set, Electron Tube TV-7A/U (serial numbers 1201 through 9492), rear-right oblique.



TM6625-274-35-28

Figure 27. Test Set, Electron Tube TV-7D/U, tubes removed, rear-right oblique.



NOTE
CR101 IS LOCATED ADJACENT
TO R118 ON SOME MODELS

TM6625-274-35-29

Figure 28. Test Set, Electron Tube TV-Y/U, direct-rear view.

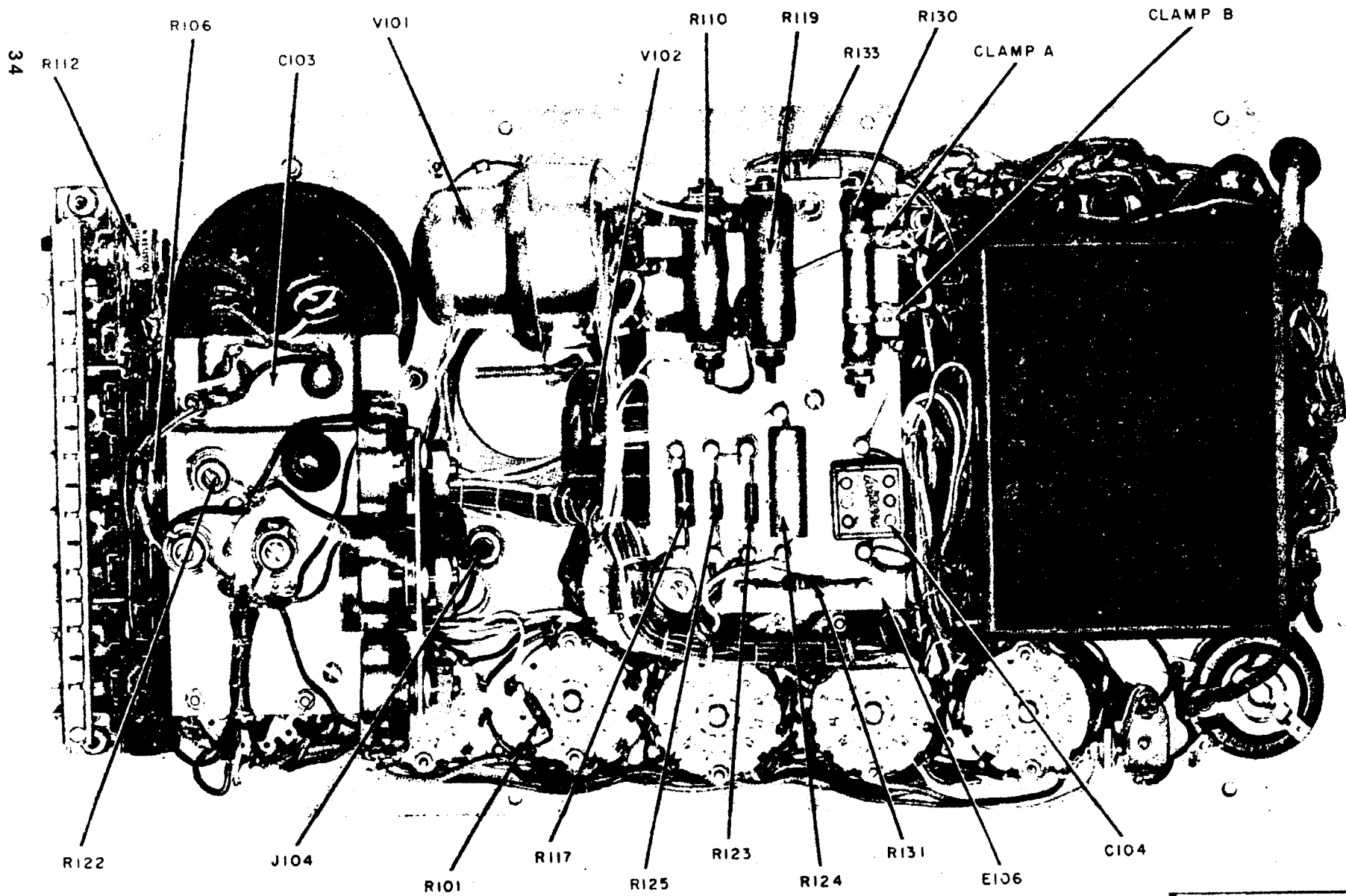

TM6625-274-35-30

Figure 29. Test Set, Electron Tube TV-7A/U (serial numbers 1 through 1200), direct-rear view.

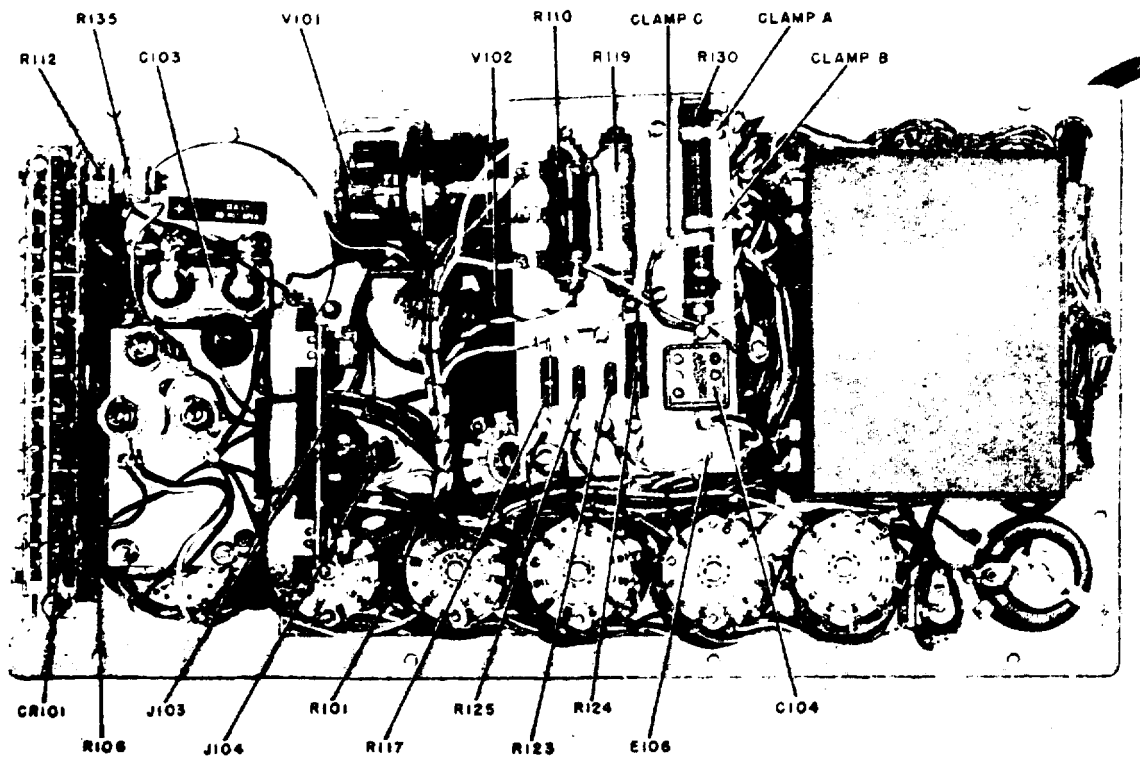

TM6625-274-35-31

Figure 30. Test Set, Electron Tube TV-7A/U (serial numbers 1201 through 9492), direct-rear view.

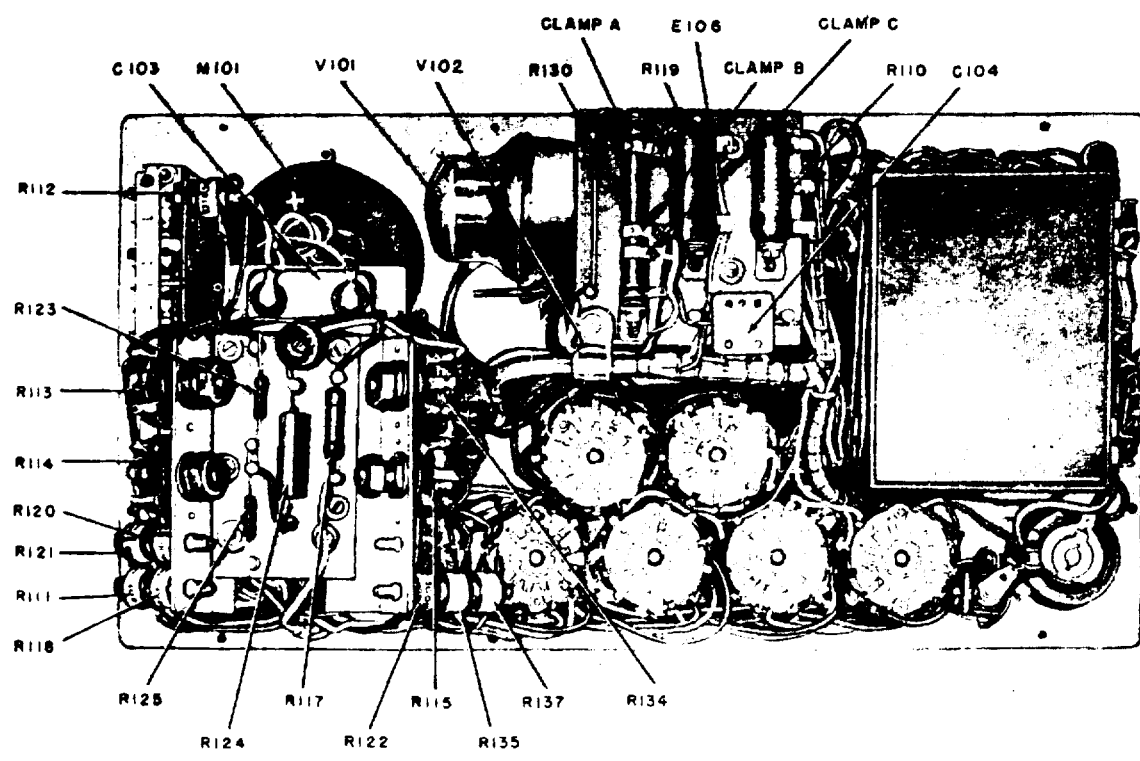

TM6625-274-35-32

Figure 31. Test Set, Electron Tube TV-7B/U, direct-rear view.

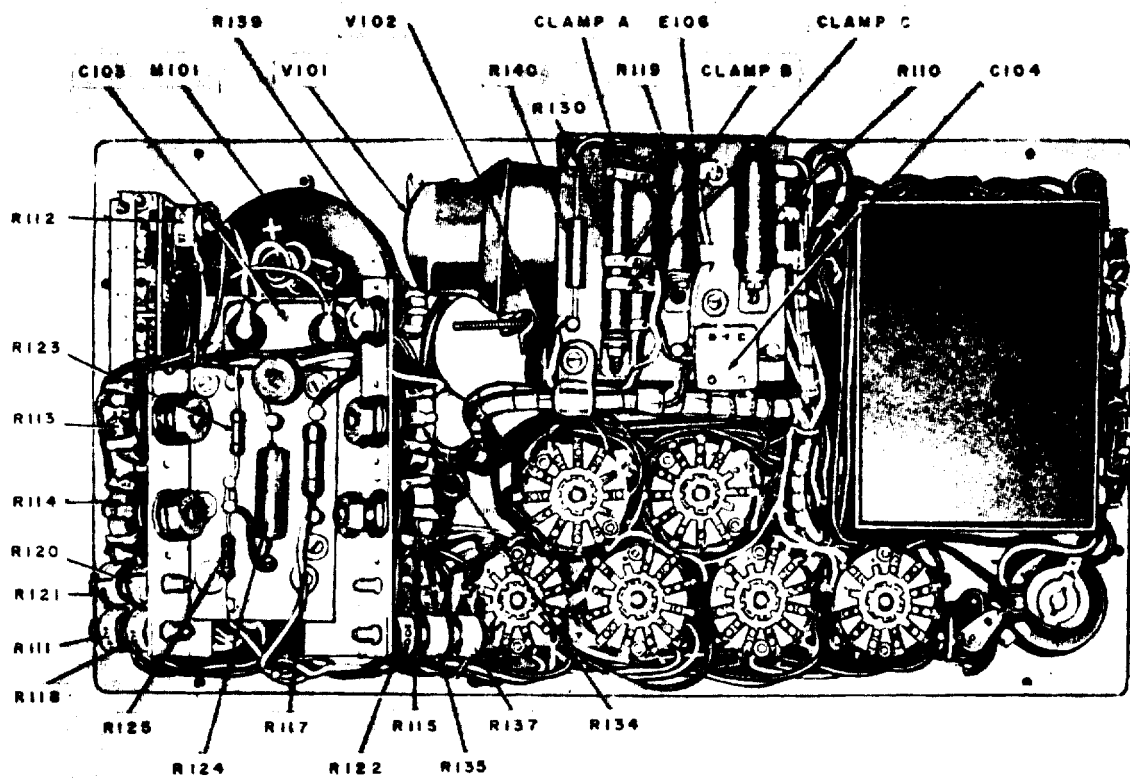

TM6625-274-35-33

Figure 32. Test Set, Electron Tube TV-7D/U, direct-rear view.

- NOTES
- VOLTAGES AND RESISTANCES MEASURED IN RESPECT TO TERMINAL 19 ON TRANSFORMER T101 VOLTAGES ARE AC UNLESS OTHERWISE INDICATED
 - DC VOLTAGES MEASURED WITH A 1000 OHMS-PER VOLT METER
 - NC INDICATES NO CONNECTION
 - VOLTAGE READINGS ABOVE LINE RESISTANCE READINGS BELOW LINE
 - RESISTORS R131 OR R132 IF USED WILL BE MOUNTED AS SHOWN
 - MEASUREMENT WILL VARY WHEN RESISTORS R131 OR R132 ARE MOUNTED ON E106
 - NO TUBE IN TEST SOCKETS
 - SWITCH SELECTOR AND CONTROL POSITIONS

SWITCH SELECTOR OR CONTROL	POSITION
FILAMENT VOLTAGE SWITCH	6 3
FILAMENT SELECTORS	H AND S
GRID SELECTOR	5
PLATE SELECTOR	3
SCREEN SELECTOR	4
CATHODE SELECTOR	6
SUPPRESSOR SELECTOR	0
FUNCTION SWITCH	B
SHUNT CONTROL	0
BIAS CONTROL	0

- DEPRESS **LINE ADJ** PUSHBUTTON AND ROTATE **LINE ADJUST** CONTROL UNTIL METER POINTER IS DIRECTLY OVER **LINE TEST** MARK

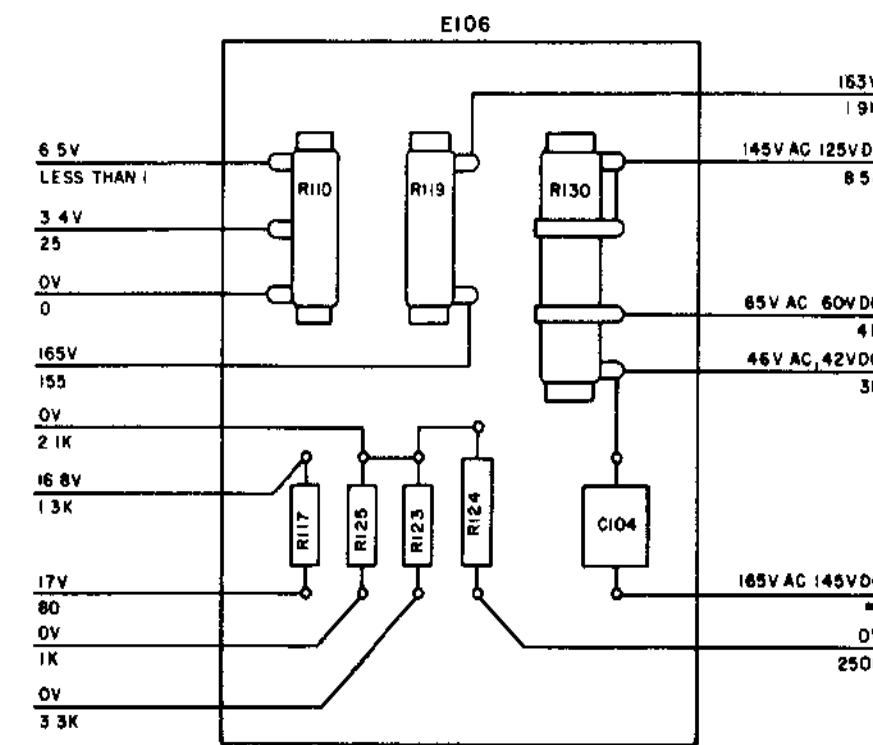

A TV-7/U

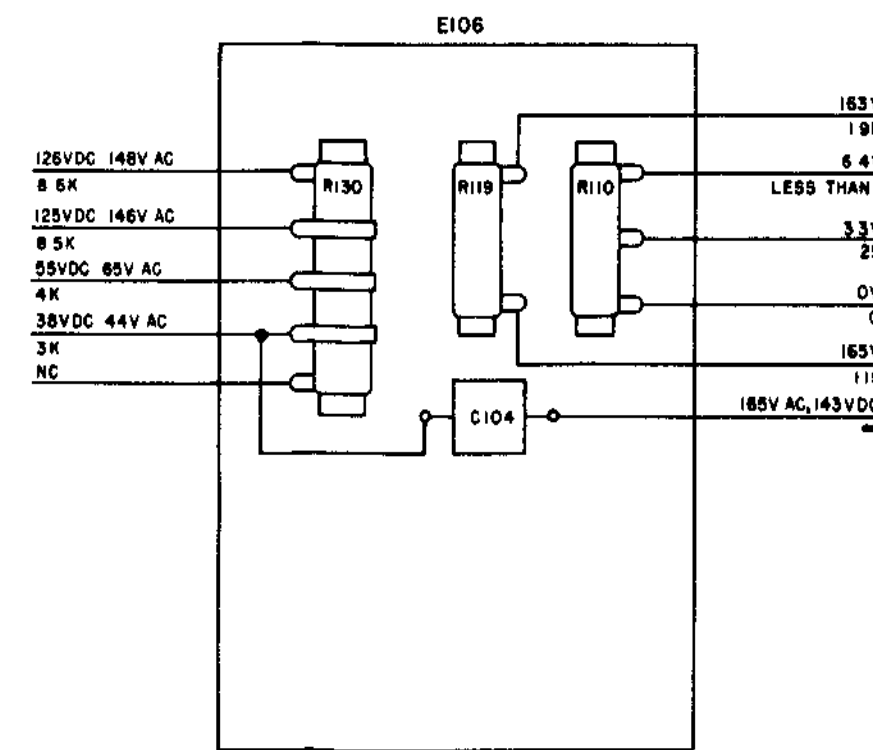

D TV-7B/U

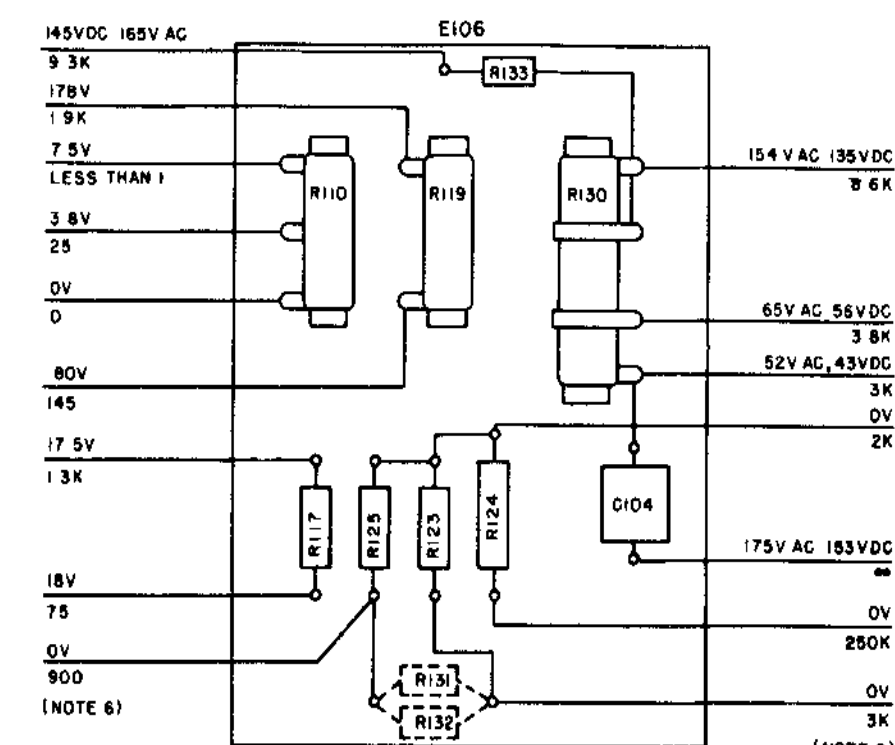

B TV-7A/U SERIAL NUMBERS 1 THROUGH 1200

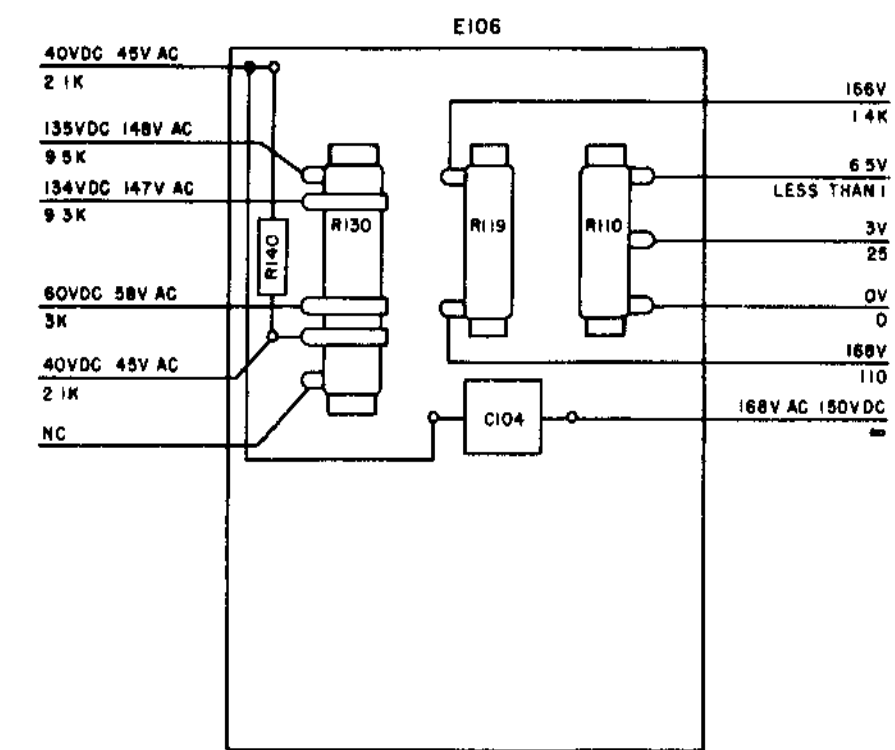

E TV-7D/U

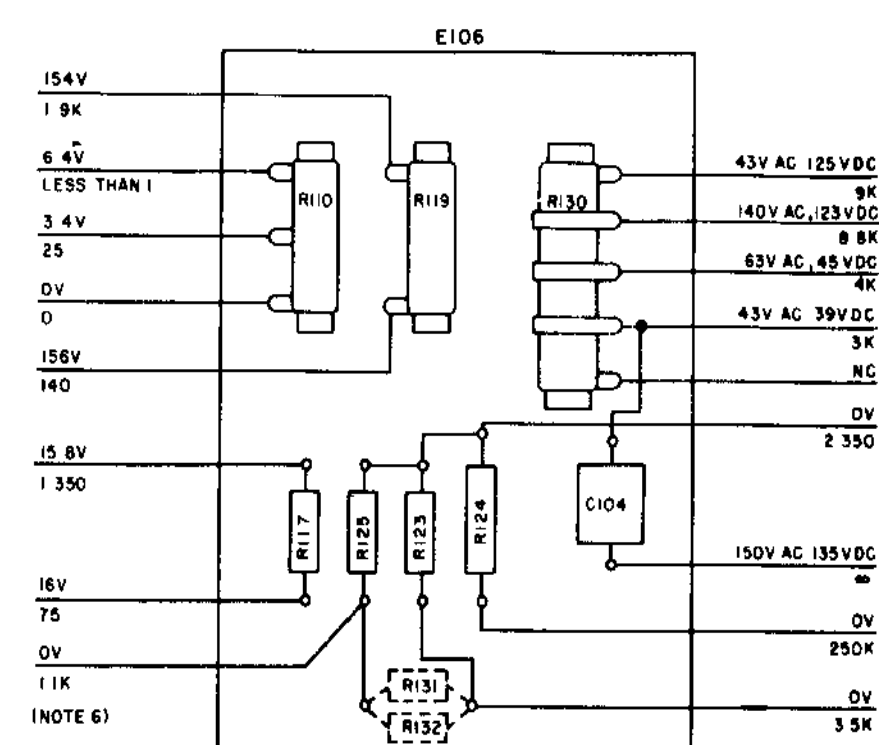

C TV-7A/U SERIAL NUMBERS 1201 THROUGH 9492

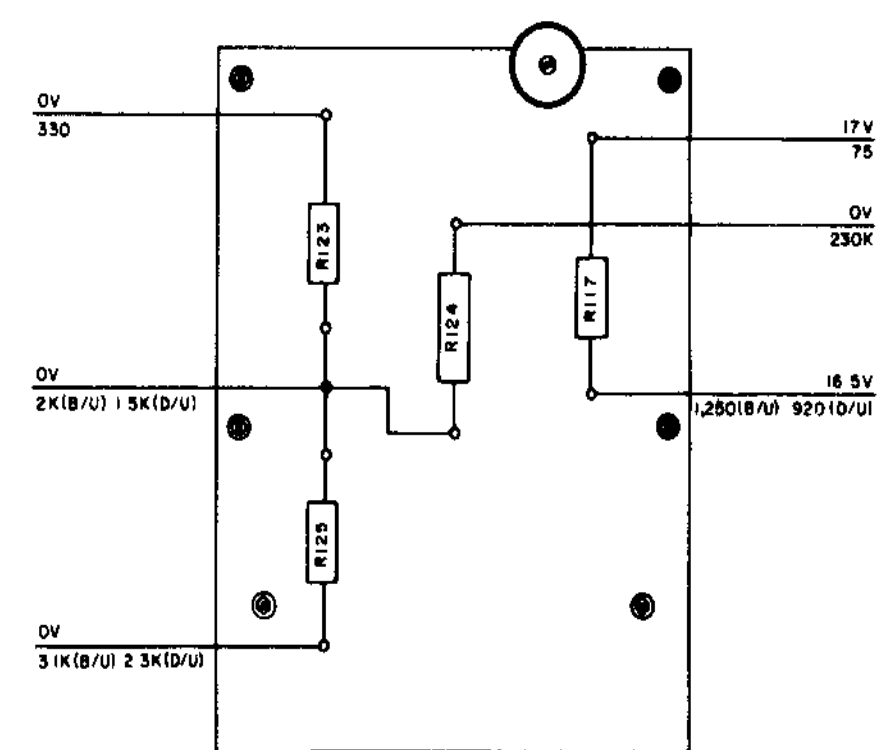

F RESISTOR MOUNTING BOARD TV-7B/U AND TV-7D/U

Figure 33. Terminal board voltage and resistance diagram,

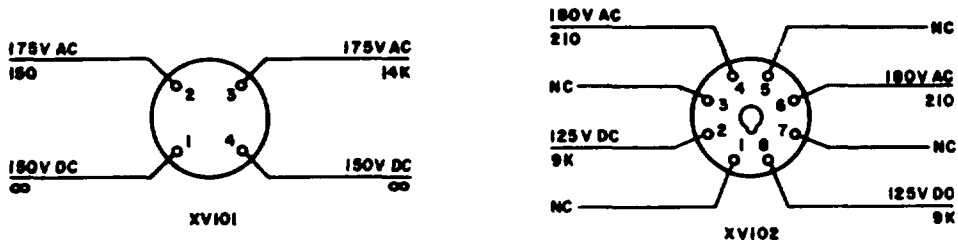

NOTES:

1. VOLTAGES AND RESISTANCES MEASURED IN RESPECT TO TERMINAL 19 ON TRANSFORMER T101.
2. DC VOLTAGES MEASURED WITH A 1,000 OHMS-PER-VOLT METER.
3. NC INDICATES NO CONNECTION.
4. VOLTAGE READINGS ABOVE LINE, RESISTANCE READINGS BELOW LINE.
5. REFER TO TERMINAL BOARD VOLTAGE AND RESISTANCE DIAGRAM FOR SWITCH, SELECTOR, AND CONTROL SETTINGS.
6. DEPRESS **LINE ADJ.** PUSH BUTTON AND ROTATE **LINE ADJUST** CONTROL UNTIL METER POINTER IS DIRECTLY OVER **LINE TEST** MARK.

TM6625-274-35-35

Figure 34. Tube socket voltage and resistance diagram.

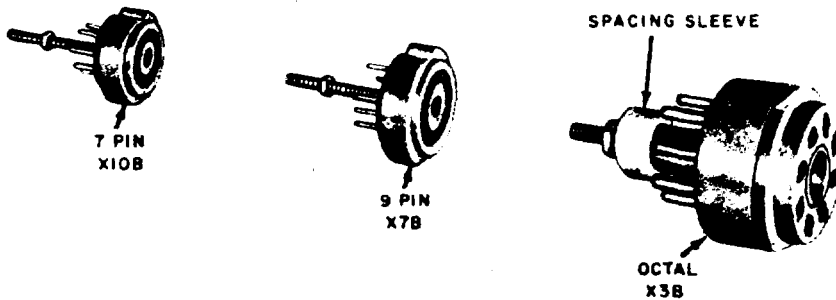

TM6625-274-35-45

Figure 35. Socket-saver adapters (TV-7D/U).

17. Dc Resistances of Transformer T101

The dc resistances of the transformer windings are listed below. Measure the resistances with the tubes removed.

Terminals	Resistance (ohms)
1-2	10.5
3-5	Less than 1
6-8	Less than 1
9-10	80
11-12	70
11-13	78
14-15	3
16-17	150
16-18	300
19-31	Less than 1
19-32	2.5
19-33	4
19-34	7
19-35	10.5
19-36	16
19-37	26

18. Replacement of Socket-Saver Adapters (TV-7D/U)

Replace socket-saver adapter X3B, X7B, or X10B (fig. 35) as follows:

- a. Removal.
 - (1) Remove the test set chassis (TM 11-6625-274-12) from the case.
 - (2) Remove the hexagonal nut from the threaded stud of the adapter to be replaced. Also, remove the spacing sleeve when replacing adapter X10B.
 - (3) Remove the adapter from the test socket.
- b. Replacement.
 - (1) Plug the adapter into its corresponding test socket. Be sure to place the spacing sleeve over the threaded stud of adapter X10B.
 - (2) Replace and tighten the hexagonal nut.
 - (3) Replace the test set chassis (TM 11-6625-274-12) in the case.

CHAPTER 3
TESTS, ADJUSTMENTS, AND CALIBRATION PROCEDURES

Section I. TESTS AND ADJUSTMENTS

19. General

All components of the test set are mounted on the rear of the front panel. Components can be adjusted or replaced without the use of special tools. The following precautions apply specifically to this equipment:

- a. Tag each lead after removing it from a component. Be careful not to damage other leads by pushing or pulling them out of the way.
- b. Do not allow drops of solder to fall into the test set.
- c. Do not disturb the adjustable contacts on R130 or the settings of variable resistors unless readjustment is indicated as a result of voltage or circuit tests (para 22-26) or replacement of the part is indicated by the troubleshooting chart (para 16c).

20. Test Equipment and Parts Required for Tests

The following charts list the test equipment and parts required to test the TV-7(*)/U, the associated technical manuals, and the assigned common names.

a. Test Equipment.

Test equipment	Technical manual	Common name
Multimeter TS-352/U	TM 11-5527	Multimeter
Resistor, Decade ZM-16/U	TM 11-5102	Decade resistor
Voltmeter, Meter ME-30A/U	TM 11-5132	Voltmeter

b. Parts.

Part	Federal stock No.
Transformer, Variable CN-16/U	5050-235-2086
Transformer (isolation)	5350-498-2146
Resistor, 10,000 ohms	5905-117-4194
Resistor, 12,000 ohms (2 each)	5905-157-5148
Resistor, 100,000 ohms	5905-120-0894
Resistor, 375,000 ohms	5905-202-0030
Resistor, 510,000 ohms	5905-279-2516

21. Test Requirements

Observe the following requirements when checking voltages (para 22-26) in the test set:

- a. Set the LINE ADJUST control so that the test set meter indicates LINE TEST when pushbutton 1 — LINE ADJ. is depressed, unless otherwise specified.
- b. Set the selectors and the controls to HS5-3460, BIAS to 0, and SHUNT to 0, unless otherwise specified.
- c. Set the POWER switch to ON at least 20 minutes before tests are made, except for the short circuit tests (para 25).

22. Bias Voltage Test

a. Connect the multimeter from the cathode to the control grid (pin 6 to pin 5) of the OCTAL test socket and adjust the BIAS control to 22. The multimeter should indicate 3 volts, ± 0.2 volt.

b. Perform the following procedure if the voltage indicated by the multimeter is incorrect:

- (1) Adjust clamp A on R130 (TV-7/U or TV-7A/U (serial numbers 1 through 1200)) until the correct voltage is obtained.
- (2) Adjust clamp C on R130 (TV-7A/U (serial numbers 1201 through 9492), TV-7B/U, or TV-7D/U) until the correct voltage is obtained.

c. Make the following bias voltage checks after the multimeter indicates 3 volts, ± 0.2 volt for a BIAS control setting of 22:

BIAS control setting	TV-7/U	TV-7A/U	TV-7B/U	TV-7D/U
50	13.4 volts, $\pm 1.$	13.7 volts, $\pm 1.$	13.4 volts, $\pm 1.$	13.4 volts, $\pm 1.$
75	25 volts, $\pm 1.4.$	26.3 volts, $\pm 1.4.$	25.8 volts, $\pm 1.$	25.8 volts, $\pm 1.$
100	40 volts, $\pm 2.$	40 volts, $\pm 2.$	40 volts, $\pm 2.$	40 volts, $\pm 2.$

aOn the TV-7D/U, adjust R139 (fig. 23) until the voltmeter indicates a bias of 4 volts ± 1 for RANGES F of the FUNCTION SWITCH.

d. Readjust the clamp (b above) until the as voltages are within the limits specified (c move) for the various BIAS control settings.

23. Plate Voltage and line Adjust Circuit Test

a. Connect a 375,000-ohm resistor (para 0b) in parallel with the multi meter from the cathode to the plate (pin 6 to pin 3) of the OCTAL test socket.

b. Depress pushbutton 3 — MUT. COND. and vary the LINE ADJUST control so that the multimeter indicates 150 volts ± 3 . The test set meter should indicate LINE TEST.

c. Perform the following procedure when the test set meter indicates below LINE TEST (TV-7/U or TV-7A/U):

- (1) Connect the decade resistor parallel to R124.
- (2) Adjust the decade resistor so that the test set meter indicates LINE TEST.
Note. The resistance should be between 2 and 15 megohms for the TV-7/U and between 1.5 and 20 megohms for the TV-7A/U.
- (3) Solder a resistor of the correct value parallel to R124.

d. Perform the following procedure when the test set meter indicates above LINE TEST (TV-7/U or TV-7A/U):

- (1) Connect the decade resistor in parallel with CR101.
- (2) Adjust the decade resistor so that the test set meter indicates LINE TEST.
Note. The resistance should be between 40,000 and 60,000 ohms for the TV-7/U and between 10,000 and 100,000 ohms for the TV-7A/U.
- (3) Solder a resistor of the correct value parallel to CR101.

e. Adjust R134 (TV-7B/U or TV-7D/U).

- (1) Determine and mark the midposition of R134.
- (2) Adjust R134 until the test set meter indicates LINE TEST. If the setting of R134 is approximately 45° to either side of the midposition ((1) above), check CR101 and R134.

24. Screen Grid Voltage Test

a. Connect a 375,000-ohm resistor (para 20b) in parallel with the multimeter from the cathode to the screen grid (pin 6 to pin 4) of the OCTAL test socket.

b. Depress pushbutton 3 — MUT. COND. and vary the LINE ADJUST control so that the multimeter indicates 130 volts ± 3 . The test set meter should indicate LINE TEST.

c. If the multimeter does not indicate 130 volts ± 3 (TV-7A/U (serial numbers 1201 through 9492), TV-7B/U, or TV-7D/U), adjust clamp A on R130 (fig. 30-32) until the correct voltage is obtained.

d. Depress both the 3 — MUT. COND. and 2 — DIODE pushbuttons. The multimeter should indicate 56 volts \pm

e. If the multimeter does not indicate 56 volts ± 1.5 (TV-7(*)/U), adjust clamp B on R130 until the correct voltage is obtained.

f. When the difference between the plate voltage and the high (130 volts ± 3) screen grid voltage is greater than 30 volts or less than 10 volts, check both rectifier tubes. Be sure that all component defects have been eliminated. If the difference between voltages is still too great or too small, proceed as follows :

- (1) Reverse the filament-cathode leads at the type 83 rectifier tube socket (pins 1 and 4), and recheck the plate (para 23b) and screen grid (b above) voltages.
- (2) If the voltage difference increased again or stayed the same, return the leads ((1) above) to their original position and reverse the filament-cathode leads of the type 5Y3WGTA rectifier tube (para 2b) at terminals 3 and 5 of T101.
- (3) Recheck the plate (para 23b) and screen grid (b above) voltages. If the voltage difference increased or stayed the same, return the leads ((2) above) to their original position.
- (4) Replace the bias potentiometer (R129) with one of a lower value. A reduction of approximately 100 ohms will reduce the high screen grid voltage approximately 1 volt.

Note. If R129 is changed, recheck the plate (para 23b) and screen grid (b above) voltages.

25. Short Circuit Tests

a. Set the selectors and the controls to HS5-3468, BIAS to 0, and SHUNT to 0.

b. Connect a 100,000-ohm resistor (para 20b) between the pins of the OCTAL test socket as indicated in the chart (c below), and rotate the FUNCTION SWITCH to positions 1 through 5.

c. The SHORTS lamp should glow in the positions marked "X" when the resistor (b above) is connected between the indicated pins on the OCTAL test socket.

Resistor connections	FUNCTION SWITCH position				
	1	2	3	4	5
Screen to suppressor (pin 4 to pin 8)	X	X	X	X	X
Screen to control grid (pin 4 to pin 5)		X	X	X	
Screen to plate (pin 4 to pin 3)		X	X		
Control grid to cathode (pin 5 to pin 6)	X	X	X		X
Control grid to suppressor (pin 5 to pin 8)	X				X
Control grid to plate (pin 5 to pin 3)				X	
Plate to suppressor (pin 3 to pin 8)	X			X	X
Filament to plate (pin 2 to pin 3)	X	X		X	X
Filament to control grid (pin 2 to pin 5)	X	X			X
Filament to screen (pin 2 to pin 4)	X		X	X	X
Filament to suppressor (pin 2 to pin 8)		X			
Filament to cathode (pin 2 to pin 6)			X		

d. Connect a 510,000-ohm resistor (para 20b) between the pins of the OCTAL test socket as indicated in the chart (c above), and rotate the FUNCTION SWITCH to positions 1 through 5. The SHORTS lamp should not glow in any combination of FUNCTION SWITCH position or resistor connection,

26. Simulated Tube Test

a. Set the FUNCTION SWITCH to RANGES B and connect the equipment as shown in figure 36.

b. Adjust the variable transformer (para 20b) so that the voltmeter indicates 50 volts,

c. Depress pushbutton 3 — MUT. COND. The test set meter should indicate 40 scale divisions $\pm 1/2$.

Note. If the meter pointer deflects to the left, reverse the power cord plug of the variable transformer.

d. If the test set meter (TV-7/U only) does not indicate 40 scale divisions \pm connect the decade resistor in parallel with R113.

(1) Adjust the decade resistor so that the test set meter indicates 40 scale divisions $\pm 1/2$.

(2) Solder a resistor of the correct value in parallel with R113.

e. When the test set meter (except for the TV-7/U) indicates more than 40.5 divisions, adjust R113 until the correct indication is obtained.

f. When the test set meter (except for the TV-7/U) indicates less than 39.5 divisions,

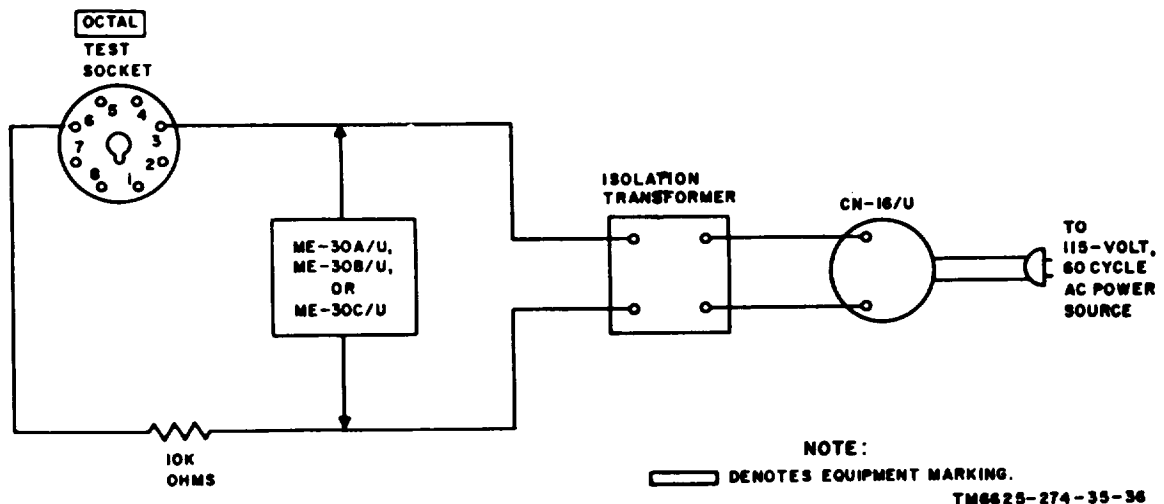

Figure 36. Connection for simulated tube test.

adjust R115 until the correct indication is obtained.

g. FUNCTION SWITCH settings and meter indications with pushbutton 3 — MUT. COND. depressed should be as follows:

(1) With the FUNCTION SWITCH in

position B, D, E, or F, the test set meter should indicate 40 scale divisions \pm

(2) With the FUNCTION SWITCH in position C, the test set meter should indicate 20 scale divisions \pm

Section II. CALIBRATION PROCEDURES

27. Shunt Control

Perform the following calibration procedure if SHUNT control R127 is out of adjustment or is replaced.

a. Set the FUNCTION SWITCH to A.

b. Depress pushbutton 1 — LINE ADJ. and vary the LINE ADJUST control until the meter pointer indicates LINE TEST.

c. Set the SHUNT control to 90.

d. Connect two 12,000-ohm resistors (para 20b) in parallel between the cathode and the plate (pin 6 to pin 3) of the OCTAL test socket.

e. Depress and hold pushbutton 3 — MUT. COND. The test set meter pointer should indicate 0 divisions ± 2 .

f. Turn the movable cap on the lower half of R127 (fig. 24–27) until the correct meter indication (e above) is obtained.

g. Release pushbutton 3 — MUT. COND. and solder the movable cap to the casing of R127.

h. Recheck for the correct meter indication (e above).

28. Range C of Function Switch

a. Set the selectors and the controls to HS5-3481, BIAS 100, and FILAMENT VOLT-

AGE 6.3. Set the FUNCTION SWITCH to RANGES B.

b. Insert a 6L6 electron tube in the OCTAL test socket. Allow the tube to warm up for at least 5 minutes.

c. Depress pushbutton 1 — LINE ADJ. and vary the LINE ADJUST control until the meter pointer indicates LINE TEST.

d. Depress pushbutton 3 — MUT. COND. and adjust the BIAS control until the meter pointer indicates 120.

e. Set the FUNCTION SWITCH to RANGES C.

f. Depress pushbutton 3 — MUT. COND. The meter pointer should indicate 60 scale divisions $\pm 1/2$.

(1) If the test set meter (TV-7/U only) does not indicate 60 scale divisions $\pm 1/2$, connect the decade resistor in parallel with R114.

(a) Adjust the decade resistor so that the test set meter indicates 60 scale divisions \pm

(b) Solder a resistor of the correct value in parallel with R114.

(2) If the test set meter (except for the TV-7/U) does not indicate 60 scale divisions $\pm 1/2$, adjust R114 until the correct indication is obtained.

CHAPTER 4
FOURTH ECHELON TESTING PROCEDURES AND FINAL TESTING

Section I. FOURTH ECHELON TESTING PROCEDURES

29. General

a. Testing procedures are prepared for use by Signal Field Maintenance Shops and Signal Service Organizations responsible for fourth echelon maintenance of signal equipment to determine the acceptability of repaired equipment. These procedures set forth specific requirements that repaired signal equipment *must* meet before it is returned to the using organization. The testing procedures may also be used as a guide for testing equipment repaired at third echelon if the proper tools and test equipment are available. A summary of the performance standard is given in paragraph 38.

b. Each test depends on the preceding one for certain operating procedures and, where applicable, for test equipment calibrations.

Comply with the instructions preceding the body of each chart before proceeding to the chart. Perform each test in sequence. Do not vary the sequence. For each step, perform all the actions required in the Test equipment, control settings and Equipment under test, control settings columns; then perform each specific test procedure and verify it against its performance standard.

30. Test Equipment and Materials Required

All test equipment, materials, and other equipment required to perform the testing procedures given in this section are listed in the following chart and are authorized under TA 11-17 and TA 11-100(11-17), or are repair part items of the subject equipment authorized for stockage at fourth echelon level.

Nomenclature	Federal stock No.	Reference
Multimeter TS-352(*)/U ^{ab}	6626-242-5023	TM 11-5527
Voltmeter, Meter ME-30A/U or Voltmeters, Electronic ME-30B/U or ME-30C/U	6625-669-0742	TM 11-5132
Light Assembly, Electric MX-1292/PAQ	6695-537-4470	TM 11-5540
Tube Socket Adapter MX-1258/U	5935-378-5009	NAVSHIPS 91798
Transformer, Variable CN-16/U	5950-235-2086	None
Resistor, 10,000 ohms	5905-199-1600	None

* Indicates model TS-352/U, TS-352A/U, or TS-352B/U.

^bMultimeter AN/URM-105 may be used in place of Multimeter TS-352 (*)/U.

31. Test Facilities

No special test facilities are required to perform the tests given in this procedure. All tests should be performed using 115- to 120-volt, 60-cycle, ac power. All connecting cords are a part of the test equipment or the equipment under test unless otherwise indicated on the applicable illustration.

32. Modification Work Orders

The performance standards listed in the tests (para 34 through 37) assume that the modification work order listed below has been performed. A listing of current modification work orders will be found in DA Pamphlet 310-4.

MWO No.	Date	Priority	Echelon	Location of MWO marking	Remarks
MWO 6626-274-36/1	24 Jun 59	N	3	Adjacent to nameplate	All sets

33. Moistureproofing and Fungiproofing

All areas, parts, and connections disturbed by repair and/or testing must be checked for proper moistureproofing and fungiproofing.

34. Physical Tests and Inspection

a. *Test Equipment and Materials.* Light

Assembly, Electric MX-1292/PAQ.

b. *Test Connections and Conditions.* All tests should be made after repair has been completed, but before the equipment has been replaced in its case.

c. *Procedure.*

Step No.	Test equipment control settings	Equipment under test control settings	Procedures	Performance standard
1	N/A	Controls may be in any position.	<p>a. Inspect case (inside and outside) and control panel for signs of physical damage, missing parts, and condition of paint.</p> <p><i>Note.</i> Touchup painting is recommended instead of refinishing. Screwheads, binding posts, receptacles, and plated fasteners will not be painted or polished with abrasives.</p> <p>b. Operate each control and switch throughout its entire range, checking for proper mechanical operation. Check for loose or missing knobs.</p> <p>c. Inspect all jacks, tube sockets, connectors, and power cord and plug.</p>	<p>a. No damage or missing parts should be evident. External surfaces intended to be painted do not show bare metal. Panel lettering is legible.</p> <p>b. Each control operates smoothly, without binding, throughout its entire range. All knobs are in place, tight, and properly indexed.</p> <p>c. All jacks, tube sockets, and connectors are in good condition, and show no signs of damage or excessive wear.</p>
2	<p>MX-1292/PAQ: Connect mercury-vapor lamp.</p> <p>Install wide transmission filter.</p>	N/A	<p>Turn on mercury-vapor lamp (switch labeled 245V) and expose that portion of the equipment that has been repaired or disturbed, to the direct rays of the lamp.</p>	<p>All parts, wires, and chassis surfaces show continuous coverage.</p> <p><i>Note.</i> MFP varnish glows gray-green under the mercury-vapor lamp.</p>

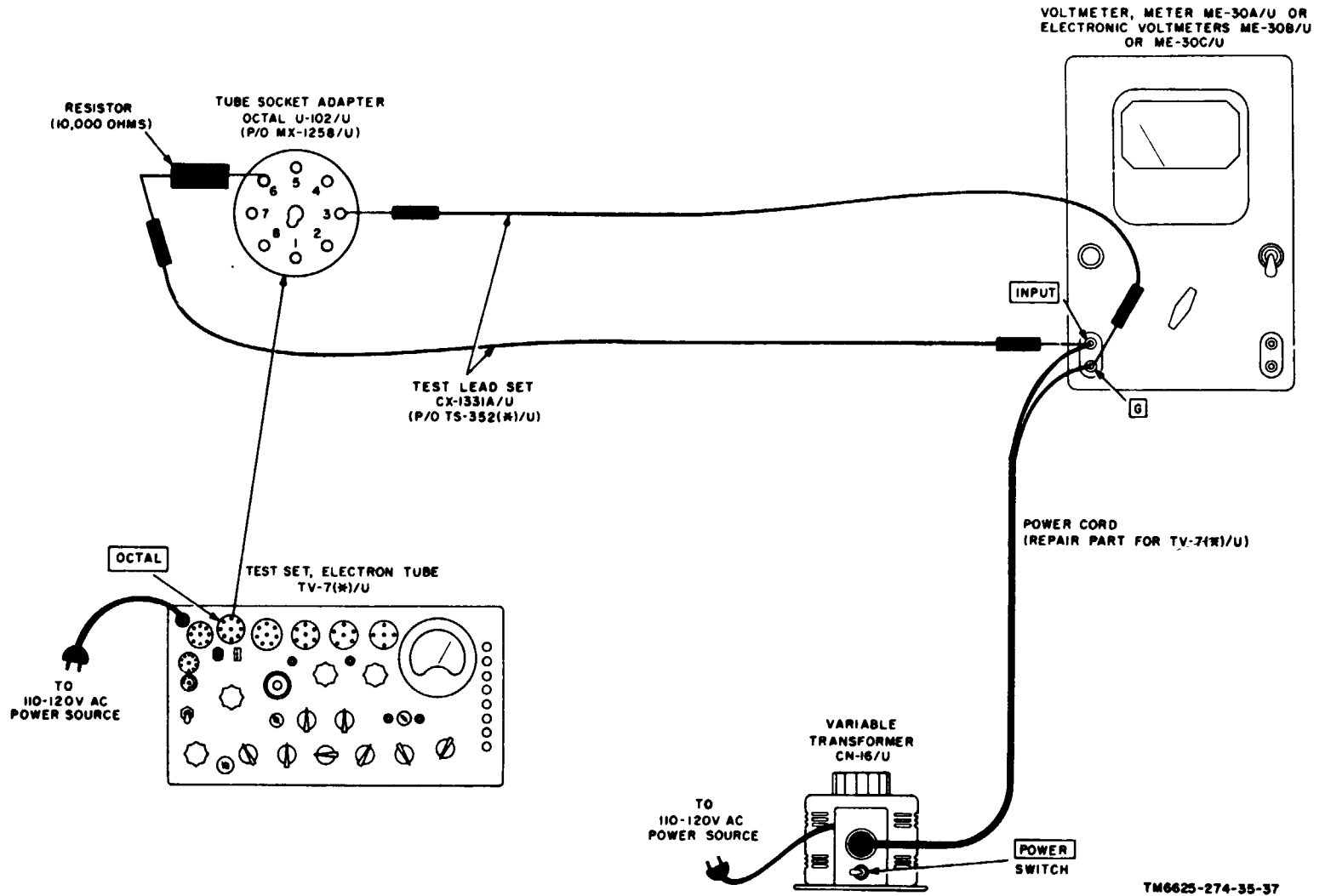

TM6625-274-35-37

Figure 37. Calibration test.

35. Calibration Test
(fig. 37)

a. *Test Equipment and Material.*

- (1) Voltmeter, Meter ME-30A/U or Electronic Voltmeter ME-30B/U or ME-30C/U.

(2) Transformer, Variable CN-16/U.

(3) Test Lead Set CX-1331A/U (p/o TS-352(*)/U).

b. *Test Connections and Conditions.* Connect the equipment as shown in figure 37.

c. Procedure.

Step No.	Test equipment control settings	Equipment under test control settings	Procedure	Performance standard
1	<p>ME-30A/U, ME-30B/U, or ME-30C/U:</p> <p>Range: 100 V</p> <p>CN-16/U:</p> <p>POWER: ON Selector dial: maximum counterclockwise.</p> <p>POWER: ON</p> <p><i>Note.</i> Adjust CN-16/U for exactly 50-volt indication on ME-30A/U, ME-30B/U, or ME-30C/U.</p>	<p>POWER: ON</p> <p>FUNCTION SWITCH: B</p> <p>BIAS: 0</p> <p>SHUNT: 0</p> <p>Selector switches:</p> <p>FILAMENT: Left: H Right: S</p> <p>GRID: 5</p> <p>PLATE: 3</p> <p>SCREEN: 4</p> <p>CATHODE: 6</p> <p>SUPPRESSOR: 0</p>	<p>a. Depress pushbutton 3 — MUT. COND. and note indication on meter of TV-7(*)/U.</p> <p><i>Note.</i> If the meter needle deflects to the left, reverse the power plug at the power source.</p> <p>b. Set FUNCTION SWITCH to C, depress pushbutton 3 — MUT. COND., and note indication on meter of TV-7(*)/U.</p> <p>c. Set FUNCTION SWITCH to D, depress pushbutton 3 — MUT. COND., and note indication on meter of TV-7(*)/U.</p> <p>d. Set FUNCTION SWITCH to E, depress pushbutton 3 — MUT. COND., and note indication on meter of TV-7(*)/U.</p> <p>e. TV-7D/U only: Set FUNCTION SWITCH to F, depress pushbutton 3 — MUT. COND., and note indication on meter of TV-7D/U.</p>	<p>a. Meter should indicate 40 scale divisions $\pm \frac{1}{2}$.</p> <p>b. Meter should indicate 20 scale divisions $\pm \frac{1}{2}$.</p> <p>c. Meter should indicate 40 scale divisions $\pm \frac{1}{2}$.</p> <p>d. Meter should indicate 40 scale divisions $\pm \frac{1}{2}$.</p> <p>e. Meter should indicate 40 scale divisions $\pm \frac{1}{2}$.</p>

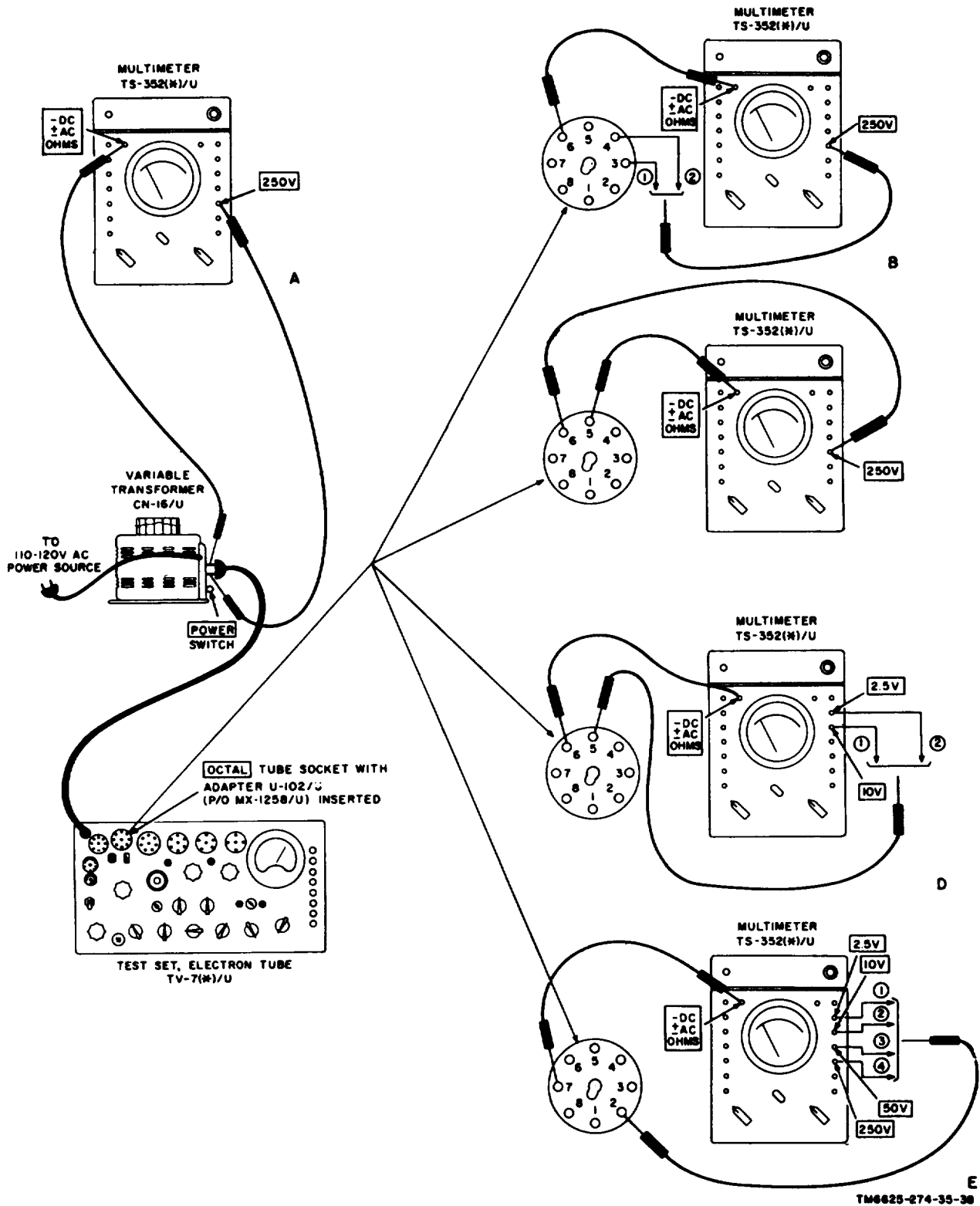

Figure 38. Voltage tests.

36. Voltage Tests
(fig.38)

(3) Transformer, Variable CN-16/U

a Test Equipment and Material
(1) Tube Socket Adapter MX-1258/U
(2) Multimeter TS-352(*)/U

b Test Connections and Conditions Connect the equipment as shown in A, figure 38
c Procedure

Step No.	Test equipment control settings	Equipment under test control settings	Procedure	Performance standard
1	TS-352(*)/U FUNCTION AC VOLTS CN-16/U Selector dial Maximum counterclock wise POWER ON <small>Note: Adjust CN-16/U for exactly 115 volt indication on TS-352(*)/U</small>	POWER ON BIAS 0 SHUNT 0 Selector switches FILAMENT Left H Right S GRID 0 PLATE 0 SCREEN 0 CATHODE 2 SUPPRESSOR: 2	a Depress pushbutton 1 — LINE ADJ., adjust LINE ADJUST control until meter pointer is over LINE TEST mark, and note position of LINE ADJUST control b Rotate FUNCTION SWITCH through positions 1, 2, 3, 4, and 5 while observing neon SHORTS lamp c Turn POWER switch of CN-16/U to OFF	a LINE ADJUST control should be near the center of its range of rotation b Neon SHORTS lamp should light on switch positions 2 and 3 c None
2	No change from step 1, except TS-352(*)/U FUNCTION 1000 Ω/VDC	No change from end of step 1, except Selector switches GRID 5 PLATE 3 SCREEN 4 CATHODE 6 SUPPRESSOR 0	a Reconnect equipment as shown in B (1), figure 38, turn POWER switch of CN-16/U to ON b Depress pushbutton 3 — MUT COND., note and record multimeter indication. c Reconnect equipment as shown in B (2), figure 38 d Depress pushbutton 3 — MUT COND., note and record multimeter indication e Reconnect equipment as shown in C figure 38 f Adjust BIAS control to 100 note and record multimeter indication	a None b Multimeter should indicate 150 volts ± 3 c None d Multimeter should indicate 130 volts ± 3 e None f Multimeter should indicate 40 volts ± 2 (4 volts ± 1-volt F range, TV-7D/U only)
3	TS-352(*)/U FUNCTION AC VOLTS	No change from end of step 2, except FUNCTION switch B BIAS 0	a Reconnect equipment as shown in D (1), figure 38 b Note and record multimeter indication c Set FUNCTION SWITCH to C, note and record multimeter indication d Reconnect equipment as shown in D (2), figure 38 e Set FUNCTION SWITCH to D, note and record multimeter indication f Set FUNCTION SWITCH to E note and record multimeter indication g Set FUNCTION SWITCH to F (TV-7D/U only), note and record multimeter indication. h Turn POWER switch of CN-16/U to OFF	a None b Multimeter should indicate 5 volts ± 0.3 c Multimeter should indicate 5 volts ± 0.3 d None e Multimeter should indicate 1 volt ± 0.1 f Multimeter should indicate 0.5 volt ± 0.05 g Multimeter should indicate +0.5 volt ± 0.05 h None
4		No changes from end of step 3, except FILAMENT VOLTAGE 6	a Reconnect equipment as shown in E (1), figure 38 b Turn POWER switch of CN-16/U to ON and note multimeter indication c Set FILAMENT VOLTAGE switch to 11 and note multimeter indication d Set FILAMENT VOLTAGE switch to 15 and note multimeter indication e Set FILAMENT VOLTAGE switch to 20 and note multimeter indication f Set FILAMENT VOLTAGE switch to 25 and note multimeter indication g Set FILAMENT VOLTAGE switch to 30 and note multimeter indication h Set FILAMENT VOLTAGE switch to 43 and note multimeter indication i Set FILAMENT VOLTAGE switch to 50 and note multimeter indication j Set FILAMENT VOLTAGE switch to 63 and note multimeter indication k Set FILAMENT VOLTAGE switch to 75 and note multimeter indication l Reconnect equipment as shown in E (2), figure 38 m Set FILAMENT VOLTAGE switch to 10 and note multimeter indication n Set FILAMENT VOLTAGE switch to 12.6 and note multimeter indication o Set FILAMENT VOLTAGE switch to 20 and note multimeter indication p Set FILAMENT VOLTAGE switch to 25 and note multimeter indication q Set FILAMENT VOLTAGE switch to 35 and note multimeter indication r Reconnect equipment as shown in E (3), figure 38 s Set FILAMENT VOLTAGE switch to 50 and note multimeter indication t Set FILAMENT VOLTAGE switch to 75 and note multimeter indication u Set FILAMENT VOLTAGE switch to 117 and note multimeter indication	a None b Multimeter should indicate from (1) 0.65 to 0.76 (2) 0.65 to 0.72 (3) 0.65 to 0.72 (4) 0.65 to 0.72 c Multimeter should indicate from (1) 1.05 to 1.15 (2) 1.05 to 1.20 (3) 1.06 to 1.16 (4) 1.06 to 1.16 d Multimeter should indicate from (1) 1.25 to 1.40 (2) 1.28 to 1.42 (3) 1.26 to 1.42 (4) 1.26 to 1.42 e Multimeter should indicate from (1) 1.90 to 2.25 (2) 1.90 to 2.25 (3) 1.90 to 2.10 (4) 1.90 to 2.10

Step No.	Test equipment control settings	Equipment under test control settings	Procedure	Performance standard
			l Reconnect equipment as shown in E (2), figure 38 o Set FILAMENT VOLTAGE switch to 25 and note multimeter indication p Set FILAMENT VOLTAGE switch to 30 and note multimeter indication q Set FILAMENT VOLTAGE switch to 43 and note multimeter indication r Set FILAMENT VOLTAGE switch to 50 and note multimeter indication s Set FILAMENT VOLTAGE switch to 63 and note multimeter indication t Set FILAMENT VOLTAGE switch to 75 and note multimeter indication u Reconnect equipment as shown in E (3), figure 38 v Set FILAMENT VOLTAGE switch to 10 and note multimeter indication w Set FILAMENT VOLTAGE switch to 12.6 and note multimeter indication x Set FILAMENT VOLTAGE switch to 20 and note multimeter indication y Set FILAMENT VOLTAGE switch to 25 and note multimeter indication z Set FILAMENT VOLTAGE switch to 35 and note multimeter indication aa Reconnect equipment as shown in E (4), figure 38 ab Set FILAMENT VOLTAGE switch to 50 and note multimeter indication ac Set FILAMENT VOLTAGE switch to 75 and note multimeter indication ad Set FILAMENT VOLTAGE switch to 117 and note multimeter indication	None Multimeter should indicate from (1) 2.58 to 2.85 (2) 2.58 to 2.85 (3) 2.58 to 2.85 (4) 2.58 to 2.85 Multimeter should indicate from (1) 3.15 to 3.60 (2) 3.25 to 3.60 (3) 3.25 to 3.60 (4) 3.25 to 3.60 Multimeter should indicate from (1) 4.25 to 4.75 (2) 4.30 to 4.75 (3) 4.30 to 4.75 (4) 4.30 to 4.75 Multimeter should indicate from (1) 5.15 to 5.65 (2) 5.35 to 5.95 (3) 5.15 to 5.68 (4) 5.15 to 5.68 Multimeter should indicate from (1) 6.2 to 6.8 (2) 6.6 to 7.2 (3) 6.2 to 6.8 (4) 6.2 to 6.8 Multimeter should indicate from (1) 7.35 to 8.1 (2) 7.4 to 8.2 (3) 7.32 to 8.1 (4) 7.32 to 8.1 None Multimeter should indicate from (1) 9.6 to 10.8 (2) 9.8 to 11 (3) 9.6 to 10.8 (4) 9.6 to 10.8 Multimeter should indicate from (1) 12.3 to 13.5 (2) 12.3 to 13.5 (3) 12.1 to 13.3 (4) 12.1 to 13.3 Multimeter should indicate from (1) 19 to 21 (2) 19.8 to 22 (3) 19 to 21 (4) 19 to 21 Multimeter should indicate from (1) 25.3 to 28 (2) 26.8 to 28.2 (3) 25.3 to 28 (4) 25.3 to 28 Multimeter should indicate from (1) 35.2 to 39 (2) 35.5 to 39.5 (3) 35.2 to 39 (4) 35.2 to 39 None Multimeter should indicate from (1) 51.5 to 57 (2) 51.5 to 57 (3) 51.5 to 57 (4) 51.5 to 57 Multimeter should indicate from (1) 74 to 82 (2) 74 to 82 (3) 74 to 82 (4) 74 to 82 Multimeter should indicate from (1) 116 to 128 (2) 112 to 121 (3) 115 to 127 (4) 115 to 127

38. Performance Standard Summary

1. Calibration Test

FUNCTION SWITCH position	Performance standard
a. RANGES B.	40 scale divisions \pm
b. RANGES C.	20 scale divisions \pm
c. RANGES D.	40 scale divisions \pm
d. RANGES E.	40 scale divisions \pm
e. RANGES F (TV-7D/U only).	40 scale divisions \pm

2. Voltage Tests

	Performance standard
a. LINE ADJUST control.	Midrange
b. SHORTS lamp.	Lights on 2 and 3
c. Plate voltage.	150 volts \pm
d. Screen voltage.	130 volts \pm
e. Bias voltage.	40 volts \pm (4 volts \pm 1)
f. Signal voltage.	(F range, TV-7D/U only).
(1) Range B.	5 volts \pm
(2) Range C.	5 volts \pm
(3) Range D.	1 volt \pm 0.1
(4) Range E.	0.5 volt \pm 0.05
(6) Range F (TV-7D/U only).	0.5 volt \pm 0.05

g. Filament voltage:

FILAMENT VOLTAGE switch position	Performance standard			
	TV-7/U	TV-7A/U	TV-7B/U	TV-7D/U
.6	0.65-0.76	0.65-0.72	0.65-0.72	0.65-0.72
1.1	1.05-1.15	1.06-1.20	1.06-1.16	1.06-1.16
1.5	1.25-1.40	1.28-1.42	1.26-1.42	1.26-1.42
2.0	1.90-2.10	1.90-2.25	1.90-2.10	1.90-2.10
2.5	2.58-2.85	2.58-2.85	2.58-2.85	2.58-2.85
3.0	3.15-3.60	3.15-3.60	3.25-3.60	3.26-3.60
4.3	4.25-4.75	4.30-4.75	4.30-4.75	4.30-4.75
5.0	5.15-5.65	6.35-5.95	5.15-5.68	5.15-5.68
6.3	6.20-6.80	6.60-7.20	6.20-6.80	6.20-6.80
7.5	7.35-8.10	7.40-8.20	7.32-8.10	7.32-8.10

FILAMENT VOLTAGE switch position	Performance standard			
	TV-7/U	TV-7A/U	TV-7B/U	TV-7D/U
10	9.60-10.8	9.80-11.0	9.60-10.8	9.60-10.8
12.6	12.8-13.5	12.9-13.5	12.1-13.3	12.1-18.3
20	19.0-21.0	19.8-22.0	19.0-21.0	19.0-21.0
25	25.3-28.0	26.8-28.2	25.3-23.0	26.3-28.0
36	36.2-39.0	36.5-39.5	35.2-39.0	35.2-89.0
50	51.5-57.0	51.5-57.0	51.5-67.0	61.6-67.0
75	74.0-82.0	74.0-82.0	74.0-82.0	74.0-82.0
117	116-128	112-121	116-127	116-127

3. Operational Tests

	Performance standard
a. Gas tests.	
(1) GAS 1.	155 volts ac \pm 15.5
(2) GAS 2.	180,000 ohms \pm 18,000
b. SHORTS lamp tests.	Performance standard
(1) Screen to suppressor (pins 4 and 8).	All positions
(2) Control grid to cathode (pins 6 and 6).	1, 2, 3, and 5
(3) Filament to plate (pins 2 and 3).	1, 2, 4, and 6
(4) Filament to control grid (pins 2 and 5).	1, 2, and 6
(5) Filament to screen (pins 2 and 4).	1, 3, 4, and 6
(6) Plate to suppressor (pins 3 and 8).	1, 4, and 6
(7) Control grid to suppressor (pins 5 and 8).	1 and 6
(8) Screen to control grid (pins 4 and 5).	2, 3, and 4
(9) Plate to screen (pins 3 and 4).	2 and 3
(10) Filament to suppressor (pins 2 and 8).	2
(11) Filament to cathode (pins 2 and 6).	3
(12) Plate to control grid (pins 3 and 5).	4

Section II. FINAL TESTING

39. Purpose of Final Testing

The final tests are designed to measure the performance capability of a repaired equipment. Equipment that meets the minimum standards stated in the referenced tests will furnish satisfactory operation, equivalent to that of new equipment.

40. Final Tests

There are no separate final tests for the TV-7(*)/U.

a. If the results of the tests in paragraphs

22, 23, 24, and 36, steps 3 and 4, are within the limits specified for each test, the equipment will furnish satisfactory operation, equivalent to that of new equipment.

b. If a second TV-7(*)/U is available, make a comparison check. Test several known good tubes in the test set that has been repaired; then test the same tubes in the second test set. Compare the results. If the pointers of both equipment meters indicate the same or nearly the same, the repaired test set may be returned to service.

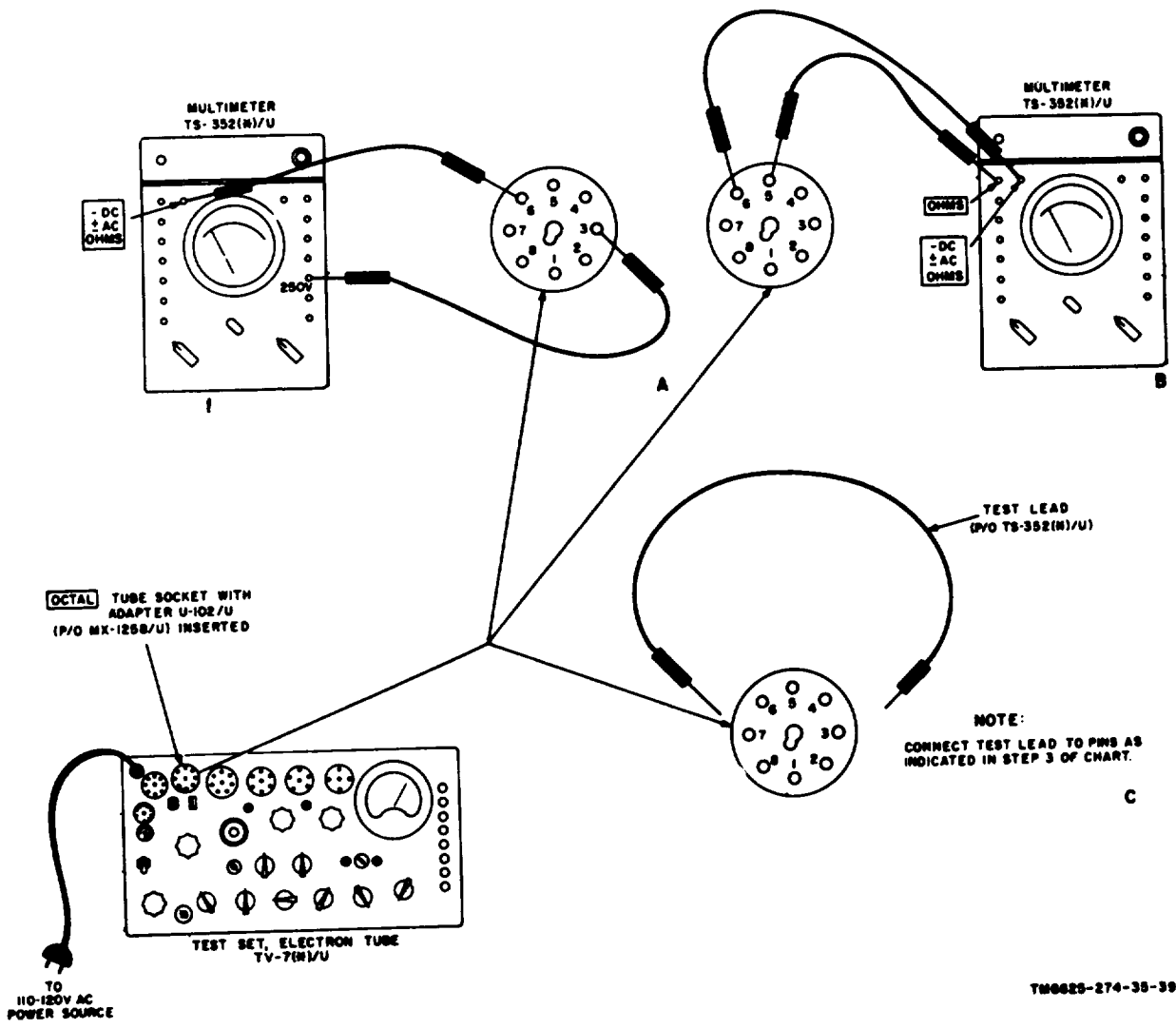
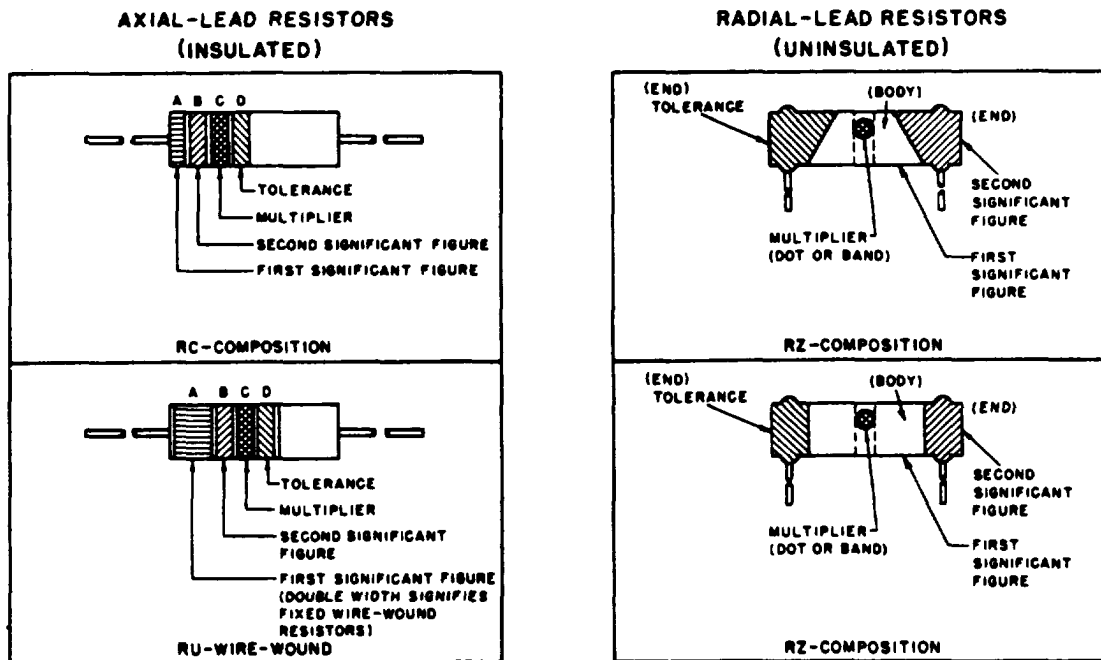

Figure 39. Operational tests.

RESISTOR COLOR CODE MARKING (MIL-STD RESISTORS)



RESISTOR COLOR CODE

BAND A OR BODY*		BAND B OR END*		BAND C OR DOT OR BAND*		BAND D OR END*	
COLOR	FIRST SIGNIFICANT FIGURE	COLOR	SECOND SIGNIFICANT FIGURE	COLOR	MULTIPLIER	COLOR	RESISTANCE TOLERANCE (PERCENT)
BLACK	0	BLACK	0	BLACK	1	BODY	± 20
BROWN	1	BROWN	1	BROWN	10	SILVER	± 10
RED	2	RED	2	RED	100	GOLD	± 5
ORANGE	3	ORANGE	3	ORANGE	1,000		
YELLOW	4	YELLOW	4	YELLOW	10,000		
GREEN	5	GREEN	5	GREEN	100,000		
BLUE	6	BLUE	6	BLUE	1,000,000		
PURPLE (VIOLET)	7	PURPLE (VIOLET)	7				
GRAY	8	GRAY	8	GOLD	0.1		
WHITE	9	WHITE	9	SILVER	0.01		

*FOR WIRE-WOUND-TYPE RESISTORS, BAND A SHALL BE DOUBLE-WIDTH. WHEN BODY COLOR IS THE SAME AS THE DOT (OR BAND) OR END COLOR, THE COLORS ARE DIFFERENTIATED BY SHADE, GLOSS, OR OTHER MEANS.

EXAMPLES (BAND MARKING):

10 OHMS ±20 PERCENT: BROWN BAND A; BLACK BAND B; BLACK BAND C; NO BAND D.
 4.7 OHMS ±5 PERCENT: YELLOW BAND A, PURPLE BANDS B; GOLD BAND C; GOLD BAND D.

EXAMPLES (BODY MARKING):

10 OHMS ±20 PERCENT: BROWN BODY; BLACK END; BLACK DOT OR BAND; BODY COLOR ON TOLERANCE END.
 3,000 OHMS ±10 PERCENT: ORANGE BODY; BLACK END; RED DOT OR BAND; SILVER END.

STD-R1

Figure 40. MIL-STD resistor color code markings.

CAPACITOR COLOR CODE MARKING (MIL-STD CAPACITORS)

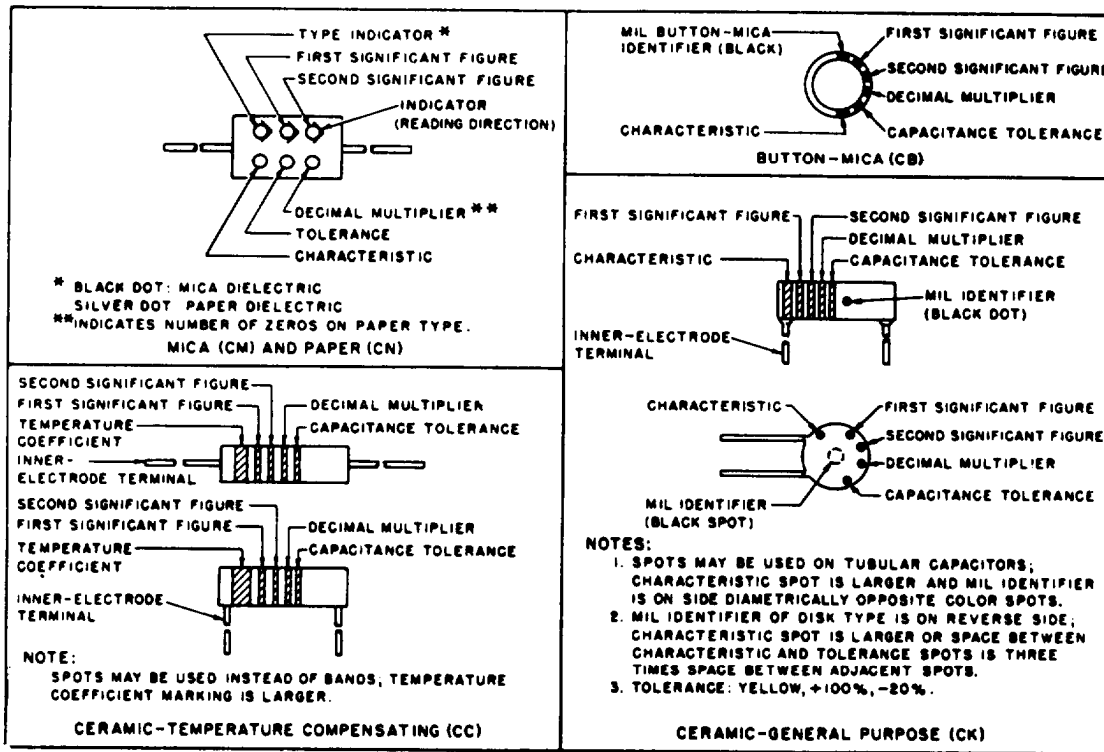

CAPACITOR COLOR CODE

COLOR	SIG FIG.	MULTIPLIER		CHARACTERISTIC				TOLERANCE 2					TEMPERATURE COEFFICIENT (UUF/UF/°C)
		DECIMAL	NUMBER OF ZEROS	CM	CN	CB	CK	CM	CN	CB	CC		
											OVER 10UUF	10UUF OR LESS	
BLACK	0	1	NONE		A			20	20	20	20	2	ZERO
BROWN	1	10	1	B	E	B	W					1	-30
RED	2	100	2	C	H		X	2		2	2		-80
ORANGE	3	1,000	3	D	J	D			30				-180
YELLOW	4	10,000	4	E	P								-220
GREEN	5		5	F	R						5	0.5	-330
BLUE	6		6		S								-470
PURPLE (VIOLET)	7		7		T	W							-780
GRAY	8		8				X					0.25	+30
WHITE	9		9								10	1	-330 (±500) 3
GOLD		0.1						5		5			+100
SILVER		0.01						10	10	10			

1. LETTERS ARE IN TYPE DESIGNATIONS GIVEN IN MIL-C SPECIFICATIONS.
2. IN PERCENT, EXCEPT IN UUF FOR CC-TYPE CAPACITORS OF 10 UUF OR LESS.
3. INTENDED FOR USE IN CIRCUITS NOT REQUIRING COMPENSATION.

STD-C1

Figure 41. MIL-STD capacitor color code markings.

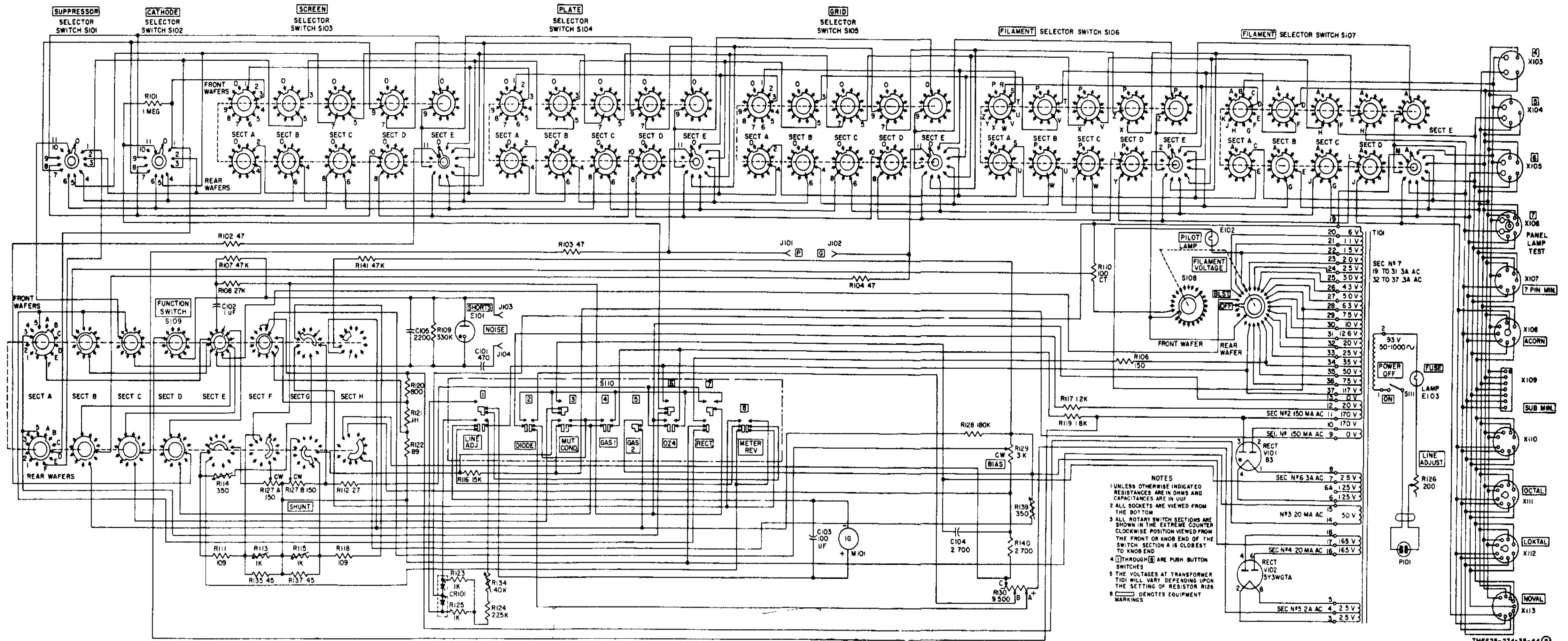

Figure 44(2). Test Set, Electron Tub TV-7D, schematic diagram (sheet 2).

SUPPRESSOR

SELECTOR SWITCH S101

SWITCH POSITION	CONTACTS MADE
0	—
1	11-1
2	11-2
3	11-3
4	11-4
5	11-5
6	11-6
7	11-7
8	11-8
9	11-9

CATHODE

SELECTOR SWITCH S102

SWITCH POSITION	CONTACTS MADE
0	—
1	11-1
2	11-2
3	11-3
4	11-4
5	11-5
6	11-6
7	11-7
8	11-8
9	11-9

SCREEN SELECTOR SWITCH S103

PLATE SELECTOR SWITCH S104 **GRID** SELECTOR SWITCH S105

SWITCH POSITION	CONTACTS MADE									
	SECT A		SECT B		SECT C		SECT D		SECT E	
	FRONT	REAR	FRONT	REAR	FRONT	REAR	FRONT	REAR	FRONT	REAR
0	1-3	2-4	3-5	4-6	5-7	6-8	7-9	8-10	0-9	—
1	—	2-4	3-5	4-6	5-7	6-8	7-9	8-10	0-9	11-1
2	1-3	—	3-5	4-6	5-7	6-8	7-9	8-10	0-9	11-2
3	1-3	2-4	—	4-6	5-7	6-8	7-9	8-10	0-9	11-3
4	1-3	2-4	3-5	—	5-7	6-8	7-9	8-10	0-9	11-4
5	1-3	2-4	3-5	4-6	—	6-8	7-9	8-10	0-9	11-5
6	1-3	2-4	3-5	4-6	5-7	—	7-9	8-10	0-9	11-6
7	1-3	2-4	3-5	4-6	5-7	6-8	—	8-10	0-9	11-7
8	1-3	2-4	3-5	4-6	5-7	6-8	7-9	—	0-9	11-8
9	1-3	2-4	3-5	4-6	5-7	6-8	7-9	8-10	—	11-9

FILAMENT SELECTOR SWITCH S106

SWITCH POSITION	CONTACTS MADE									
	SECT A		SECT B		SECT C		SECT D		SECT E	
	FRONT	REAR	FRONT	REAR	FRONT	REAR	FRONT	REAR	FRONT	REAR
P	R-T	S-U	T-V	U-W	V-X	W-Y	X-Z	Y-I	P-Z	—
R	—	S-U	T-V	U-W	V-X	W-Y	X-Z	Y-I	P-Z	2-R
S	R-T	—	T-V	U-W	V-X	W-Y	X-Z	Y-I	P-Z	2-S
T	R-T	S-U	—	U-W	V-X	W-Y	X-Z	Y-I	P-Z	2-T
U	R-T	S-U	T-V	—	V-X	W-Y	X-Z	Y-I	P-Z	2-U
V	R-T	S-U	T-V	U-W	—	W-Y	X-Z	Y-I	P-Z	2-V
W	R-T	S-U	T-V	U-W	V-X	—	X-Z	Y-I	P-Z	2-W
X	R-T	S-U	T-V	U-W	V-X	W-Y	—	Y-I	P-Z	2-X
Y	R-T	S-U	T-V	U-W	V-X	W-Y	X-Z	—	P-Z	2-Y
Z	R-T	S-U	T-V	U-W	V-X	W-Y	X-Z	Y-I	—	2-Z

FILAMENT SELECTOR SWITCH S107

SWITCH POSITION	CONTACTS MADE									
	SECT A		SECT B		SECT C		SECT D		SECT E	
	FRONT	REAR	FRONT	REAR	FRONT	REAR	FRONT	REAR	FRONT	REAR
A	B-D	C-E	D-F	E-G	F-H	G-J	H-K	J-L	K-A	—
B	—	C-E	D-F	E-G	F-H	G-J	H-K	J-L	K-A	M-B
C	B-D	—	D-F	E-G	F-H	G-J	H-K	J-L	K-A	N-C
D	B-D	C-E	—	E-G	F-H	G-J	H-K	J-L	K-A	N-D
E	B-D	C-E	D-F	—	F-H	G-J	H-K	J-L	K-A	N-E
F	B-D	C-E	D-F	E-G	—	G-J	H-K	J-L	K-A	N-F
G	B-D	C-E	D-F	E-G	F-H	—	H-K	J-L	K-A	N-G
H	B-D	C-E	D-F	E-G	F-H	G-J	—	J-L	K-A	N-H
J	B-D	C-E	D-F	E-G	F-H	G-J	H-K	—	K-A	N-J
K	B-D	C-E	D-F	E-G	F-H	G-J	H-K	J-L	—	N-K

FUNCTION SWITCH S109

SWITCH POSITION	CONTACTS MADE							
	SECT A		SECT B		SECT C		SECT D	
	FRONT	REAR	FRONT	REAR	FRONT	REAR	FRONT	REAR
1	3-X	A-D	3-X	A-D	3-X	A-D	3-X	A-D
2	3-X	A-D	3-X	A-D	3-X	A-D	3-X	A-D
3	3-X	A-D	3-X	A-D	3-X	A-D	3-X	A-D
4	3-X	A-D	3-X	A-D	3-X	A-D	3-X	A-D
5	3-X	A-D	3-X	A-D	3-X	A-D	3-X	A-D
A	3-5	F-D	3-5	F-D	3-5	F-D	—	F-D
B	3-5	F-D	3-5	F-D	3-5	F-D	—	F-D
C	3-5	F-D	3-5	F-D	3-5	F-D	—	F-D
D	3-5	F-D	3-5	F-D	3-5	F-D	—	F-D
E	3-5	F-D	3-5	F-D	3-5	F-D	—	F-D

FILAMENT VOLTAGE

SWITCH S108

SWITCH POSITIONS	CONTACT MADE	
	FRONT	REAR
OFF	—	—
BLST	A-B	C-BLST
6	A-B	C-6
11	A-B	C-11
15	A-B	C-15
20	A-B	C-20
25	A-B	C-25
30	A-B	C-30
43	A-B	C-43
50	A-B	C-50
63	A-B	C-63
75	A-B	C-75
10	A-B	C-10
126	A-B	C-126
20	—	C-20
25	—	C-25
35	—	C-35
50	—	C-50
75	—	C-75
117	—	C-117

FUNCTION SWITCH S109 CONT

SWITCH POSITION	CONTACTS MADE			
	SECT E		SECT F	
	FRONT	REAR	FRONT	REAR
1	B-C-D-E-F-X-1,2,3,4,5,A	—	F-X-5,A	3,4-C,D
2	C-D-E-F-X-1,2,3,4,5,A,B	—	F-X-5,A	1,3,4-C,D
3	D-E-F-X-1,2,3,4,5,A,B,C	—	F-X-5,A	3,4-C,D
4	E-F-X-1,2,3,4,5,A,B,C,D	—	F-X-5,A	3,4-C,D
5	F-X-1,2,3,4,5,A,B,C,D,E	—	—	4-D
A	A-B-C-D-E-F-X-1,2,3,4,5	A-5	B-F-1,5	E-3-C,5
B	B-C-D-E-F-X-1,2,3,4,5	A-5	F-X-5,A	3,4-C,D
C	C-D-E-F-X-1,2,3,4,5,A,B	A-5	F-X-5,A	3,4-C,D
D	D-E-F-X-1,2,3,4,5,A,B,C	A-B	F-X-5,A	3,4-C,D
E	E-F-X-1,2,3,4,5,A,B,C,D	A-B-C	F-X-5,A	3,4-C,D

Figure 42(1). Test Sets, Electron Tube TV-7/U and TV-7A/U (serial numbers 1 through 1200), schematic diagram (sheet 1)

NOTES

- 1 UNLESS OTHERWISE INDICATED RESISTANCES ARE IN OHMS AND CAPACITANCES ARE IN UUF
- 2 ALL SOCKETS ARE VIEWED FROM THE BOTTOM
- 3 ALL ROTARY SWITCH SECTIONS ARE SHOWN IN EXTREME COUNTERCLOCKWISE POSITION VIEWED FROM FRONT OR KNOB END OF SWITCH SECTION A IS CLOSEST TO KNOB END.
- 4 **I** THROUGH **E** ARE PUSH BUTTON SWITCHES
- 5 RESISTOR R114 IS NOT VARIABLE ON TV 7/U
- 6 RESISTORS R113 AND R115 ARE NOT VARIABLE ON TV 7/U
- 7 THE VALUES OF RESISTORS R131 AND R132 ARE DETERMINED IN PRODUCTION IF USED, THE RESISTANCE RANGE IS 10K TO 20K THESE RESISTORS ARE NOT USED ON TV 7/U
- 8 RESISTOR R133 680 OHMS IS NOT USED ON TV-7/U
- 9 THE VOLTAGES AT TRANSFORMER T101 WILL VARY DEPENDING UPON THE SETTING OF RESISTOR R126
- 10  DEMOTES EQUIPMENT MARKINGS

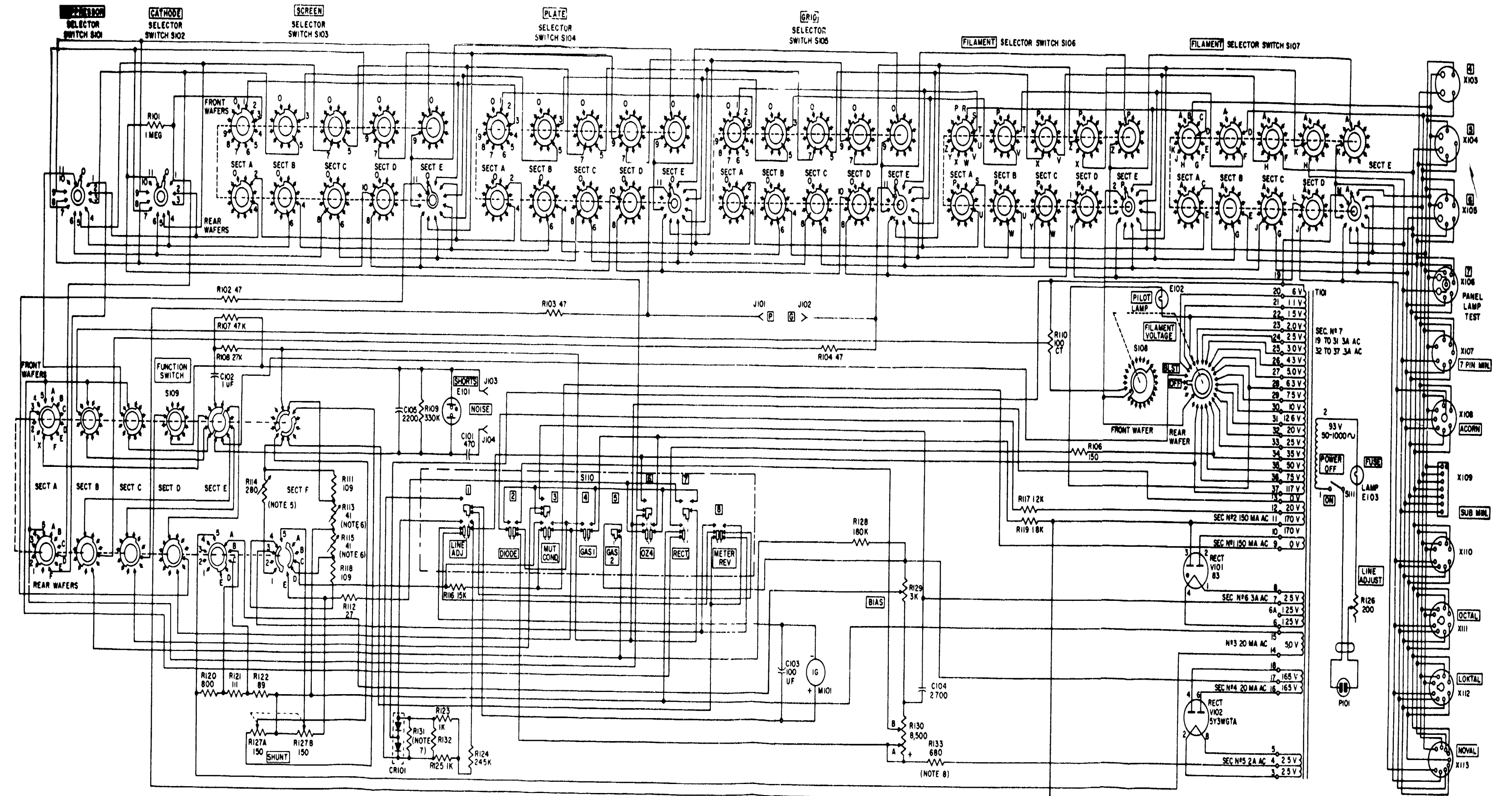

Figure 42(2). Test Sets, Electron Tube TV-7/U and TV-7A/U (serial numbers 1 through 1200), schematic diagram (sheet 2).

- NOTES**
- 1 UNLESS OTHERWISE INDICATED, RESISTANCES ARE IN OHMS AND CAPACITANCES ARE IN UUF
 - 2 ALL SOCKETS ARE VIEWED FROM THE BOTTOM
 - 3 ALL ROTARY SWITCH SECTIONS ARE SHOWN IN EXTREME COUNTERCLOCKWISE POSITION VIEWED FROM FRONT OR KNOB END OF SWITCH. SECTION A IS CLOSEST TO KNOB END
 - 4 [1] THROUGH [6] ARE PUSH BUTTON SWITCHES
 - 5 RESISTOR R114 HAS A VALUE OF 350 OHMS ON TV 7B/U
 - 6 RESISTORS R135 AND R137 ARE DESIGNATED AS RESISTORS R134 AND R135 RESPECTIVELY ON TV 7A/U. SERIAL NUMBERS 1201 THROUGH 9492
 - 7 THE VALUES OF RESISTORS R131 AND R132 ARE DETERMINED IN PRODUCTION IF USED. THE RESISTANCE RANGE IS 10K TO 20K. THESE RESISTORS ARE NOT USED ON TV 7B/U
 - 8 RESISTOR R124 HAS A VALUE OF 225K OHMS ON TV 7B/U
 - 9 VARIABLE RESISTOR R134 40K OHMS IS NOT USED ON TV 7A/U. SERIAL NUMBERS 1201 THROUGH 9492
 - 10 THE VOLTAGES AT TRANSFORMER T101 WILL VARY DEPENDING UPON THE SETTING OF RESISTOR R126
 - 11 REFER TO TV 7/U AND TV 7A/U (SERIAL NUMBERS 1 THROUGH 1200) SCHEMATIC DIAGRAM FOR SWITCH CONTACTS MADE
 - 12 [] DENOTES EQUIPMENT MARKINGS

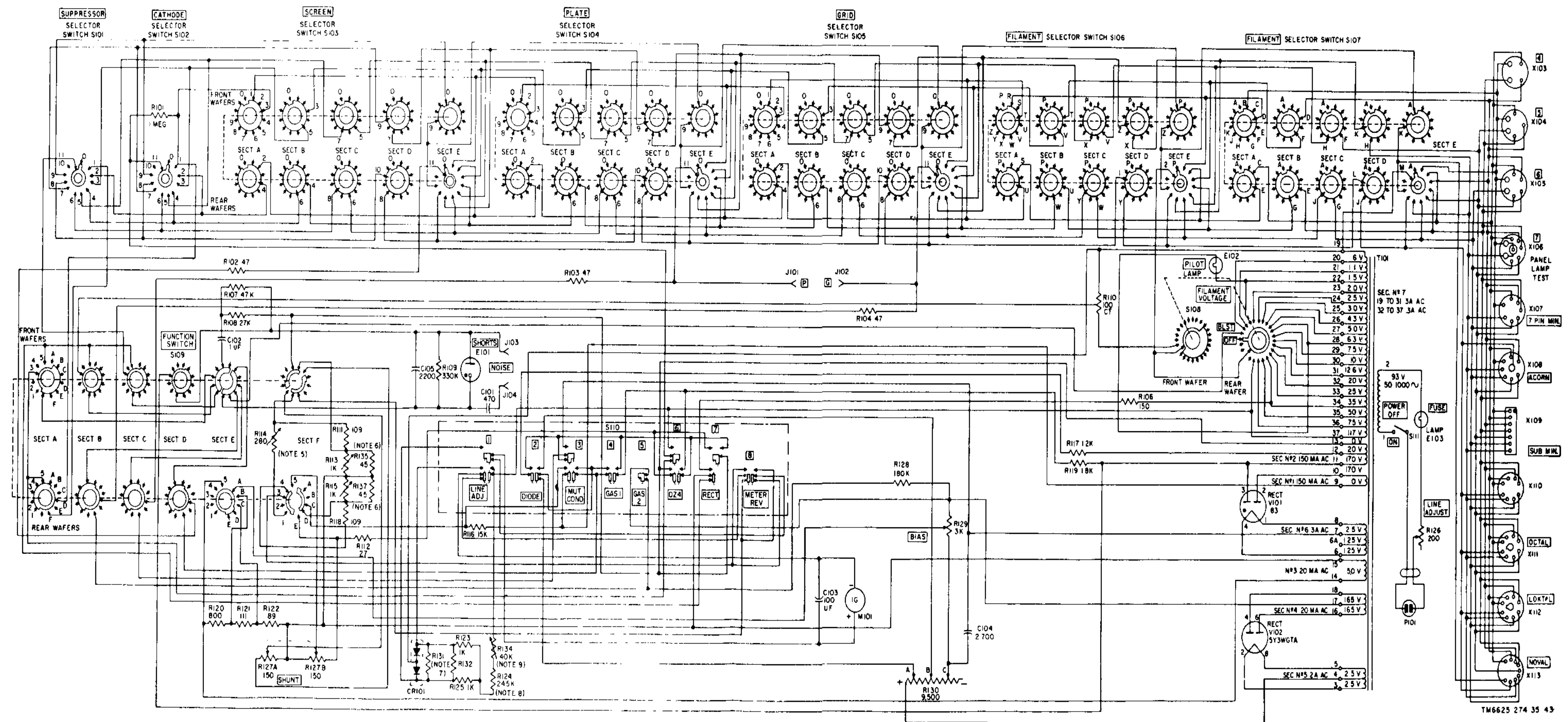

Figure 43. Test Sets, Electron Tube TV-A/U (serial numbers 1201 through 9492) and TV-7B/U, schematic diagram.

**SUPPRESSOR
SELECTOR
SWITCH S101**

SWITCH POSITION	CONTACTS MADE	
	SECT A	
0	-	
1	11-1	
2	11-2	
3	11-3	
4	11-4	
5	11-5	
6	11-6	
7	11-7	
8	11-8	
9	11-9	

**CATHODE
SELECTOR
SWITCH S102**

SWITCH POSITION	CONTACTS MADE	
	SECT A	
0	-	
1	11-1	
2	11-2	
3	11-3	
4	11-4	
5	11-5	
6	11-6	
7	11-7	
8	11-8	
9	11-9	

FILAMENT SELECTOR SWITCH S107

SWITCH POSITION	CONTACTS MADE									
	SECT A		SECT B		SECT C		SECT D		SECT E	
	FRONT	REAR	FRONT	REAR	FRONT	REAR	FRONT	REAR	FRONT	REAR
A	B-D	C-E	D-F	E-G	F-H	G-J	H-K	J-L	K-A	-
B	-	C-E	D-F	E-G	F-H	G-J	H-K	J-L	K-A	M-B
C	B-D	-	D-F	E-G	F-H	G-J	H-K	J-L	K-A	M-C
D	B-D	C-E	-	E-G	F-H	G-J	H-K	J-L	K-A	M-D
E	B-D	C-E	D-F	-	F-H	G-J	H-K	J-L	K-A	M-E
F	B-D	C-E	D-F	E-G	-	G-J	H-K	J-L	K-A	M-F
G	B-D	C-E	D-F	E-G	F-H	-	H-K	J-L	K-A	M-G
H	B-D	C-E	D-F	E-G	F-H	G-J	-	J-L	K-A	M-H
J	B-D	C-E	D-F	E-G	F-H	G-J	H-K	-	K-A	M-J
K	B-D	C-E	D-F	E-G	F-H	G-J	H-K	J-L	-	M-K

FUNCTION SWITCH S109

SWITCH POSITION	CONTACTS MADE							
	SECT A		SECT B		SECT C		SECT D	
	FRONT	REAR	FRONT	REAR	FRONT	REAR	FRONT	REAR
1	3-F	5-D	3-F	5-D	3-F	5-D	3-F	5-D
2	3-F	5-D	3-F	5-D	3-F	5-D	3-F	5-D
3	3-F	5-D	3-F	5-D	3-F	5-D	3-F	5-D
4	3-F	5-D	3-F	5-D	3-F	5-D	3-F	5-D
5	3-F	5-D	3-F	5-D	3-F	5-D	3-F	5-D
A	3-5	F-D	3-5	F-D	3-5	F-D	-	F-D
B	3-5	F-D	3-5	F-D	3-5	F-D	-	F-D
C	3-5	F-D	3-5	F-D	3-5	F-D	-	F-D
D	3-5	F-D	3-5	F-D	3-5	F-D	-	F-D
E	3-5	F-D	3-5	F-D	3-5	F-D	-	F-D
F	3-5	F-D	3-5	F-D	3-5	F-D	-	F-D

SCREEN SELECTOR SWITCH S103

PLATE SELECTOR SWITCH S104 GRID SELECTOR SWITCH S105

SWITCH POSITION	CONTACTS MADE									
	SECT A		SECT B		SECT C		SECT D		SECT E	
	FRONT	REAR	FRONT	REAR	FRONT	REAR	FRONT	REAR	FRONT	REAR
0	1-3	2-4	3-5	4-6	5-7	6-8	7-9	8-10	0-9	-
1	-	2-4	3-5	4-6	5-7	6-8	7-9	8-10	0-9	11-1
2	1-3	-	3-5	4-6	5-7	6-8	7-9	8-10	0-9	11-2
3	1-3	2-4	-	4-6	5-7	6-8	7-9	8-10	0-9	11-3
4	1-3	2-4	3-5	-	5-7	6-8	7-9	8-10	0-9	11-4
5	1-3	2-4	3-5	4-6	-	6-8	7-9	8-10	0-9	11-5
6	1-3	2-4	3-5	4-6	5-7	-	7-9	8-10	0-9	11-6
7	1-3	2-4	3-5	4-6	5-7	6-8	-	8-10	0-9	11-7
8	1-3	2-4	3-5	4-6	5-7	6-8	7-9	-	0-9	11-8
9	1-3	2-4	3-5	4-6	5-7	6-8	7-9	8-10	-	11-9

**FILAMENT VOLTAGE
SWITCH S108**

SWITCH POSITIONS	CONTACT MADE	
	FRONT	REAR
OFF	-	-
BLST	A-B	C-BLST
6	A-B	C-6
11	A-B	C-11
15	A-B	C-15
20	A-B	C-20
25	A-B	C-25
30	A-B	C-30
43	A-B	C-43
50	A-B	C-50
63	A-B	C-63
75	A-B	C-75
10	A-B	C-10
128	A-B	C-128
20	-	C-20
25	-	C-25
35	-	C-35
50	-	C-50
75	-	C-75
117	-	C-117

FUNCTION SWITCH S109 CONT

SWITCH POSITION	CONTACTS MADE							
	SECT E		SECT F		SECT G		SECT H	
	FRONT	REAR	FRONT	REAR	FRONT	REAR	FRONT	REAR
1	B-C-D-E, F-X-1, 2, 3, 4, 5, A	-	-	-	-	-	-	-
2	C-D-E-F, X-1, 2, 3, 4, 5, A, B	-	-	-	-	-	-	-
3	D-E-F-X-1, 2, 3, 4, 5, A, B, C	-	-	-	-	-	-	-
4	E-F-X-1, 2, 3, 4, 5, A, B, C, D	-	-	-	-	-	-	-
5	F-X-1, 2, 3, 4, 5, A, B, C, D, E	-	-	-	-	-	-	-
A	A-B-C-D-E-F-X-1, 2, 3, 4, 5	C-1	B-5	F-4	D-2	D-4	-	4-5
B	B-C-D-E-F-X-1, 2, 3, 4, 5, A	2-1	5-A-B	5-4	2-3	D-E	-	4-5
C	C-D-E-F-X-1, 2, 3, 4, 5, A, B	2-1	A-B	5-4	F-2-3	D-E	-	4-5
D	D-E-F-X-1, 2, 3, 4, 5, A, B, C	2-1	B-C	5-4	2-3	D-E	-	4-5
E	E-F-X-1, 2, 3, 4, 5, A, B, C, D	2-1	B-C-D	5-4	2-3	D-E	-	4-5
F	F-X-1, 2, 3, 4, 5, A, B, C, D, E	2-1	B-D-E	5-4	2-3-8	D-E	1-2	5-E

FILAMENT SELECTOR SWITCH S106

SWITCH POSITION	CONTACTS MADE									
	SECT A		SECT B		SECT C		SECT D		SECT E	
	FRONT	REAR	FRONT	REAR	FRONT	REAR	FRONT	REAR	FRONT	REAR
P	R-T	S-U	T-V	U-W	V-X	W-Y	X-Z	Y-1	P-Z	-
R	-	S-U	T-V	U-W	V-X	W-Y	X-Z	Y-1	P-Z	2-R
S	R-T	-	T-V	U-W	V-X	W-Y	X-Z	Y-1	P-Z	2-S
T	R-T	S-U	-	U-W	V-X	W-Y	X-Z	Y-1	P-Z	2-T
U	R-T	S-U	T-V	-	V-X	W-Y	X-Z	Y-1	P-Z	2-U
V	R-T	S-U	T-V	U-W	-	W-Y	X-Z	Y-1	P-Z	2-V
W	R-T	S-U	T-V	U-W	V-X	-	X-Z	Y-1	P-Z	2-W
X	R-T	S-U	T-V	U-W	V-X	W-Y	-	Y-1	P-Z	2-X
Y	R-T	S-U	T-V	U-W	V-X	W-Y	X-Z	-	P-Z	2-Y
Z	R-T	S-U	T-V	U-W	V-X	W-Y	X-Z	Y-1	-	2-Z

Figure 44(1). Test Set, Electron Tube TV-7D/U, schematic diagram (sheet 1).

37. Operational Tests

(fig. 39)

37. Operational Tests
(fig 39)

a Test Equipment and Material

- (1) Multimeter TS-352(*)/U
- (2) Tube socket Adapter MX-1258/U
- (3) Electron tubes, types OC3, 5Y3, 6AU6,

6L6, and 5678

Note All electron tubes used must be known to be good tubes

- b Test Connections and Conditions* Connect equipment as shown in A, figure 39
- c Procedure*

Step No.	Test equipment control settings	Equipment under test settings	Procedure	Performance standard
1	TS-352(*)/U FUNCTION AC VOLTS	FILAMENT VOLTAGE OFF POWER ON Selector switches Filament Left H Right S GRID 5 PLATE 3 SCREEN 4 CATHODE 6 SUPPRESSOR 0	<p><i>a</i> Depress pushbutton 4 — GAS meter indication</p> <p><i>b</i> Turn POWER switch to OFF, reconnect equipment as shown in (B) figure 39, and set multimeter FUNCTION switch to OHMS and RANGE switch to Rx10000</p> <p><i>Caution</i> Do not turn power on during rest of step Power will damage the multimeter</p> <p><i>c</i> Depress pushbutton 5 — GAS meter indication</p> <p><i>d</i> Disconnect all equipment</p>	<p><i>a</i> Multimeter should indicate 155 volts ± 15.5</p> <p><i>b</i> None</p> <p><i>c</i> Multimeter should indicate 180,000 ohms $\pm 18,000$</p> <p><i>d</i> None</p>
2	None	POWER ON LINE ADJUST Set for meter indication of LINE TEST with pushbutton 1 — LINE ADJ depressed	Using the instructions in the test data book, check each of the following electron tubes OC3 5Y3 6AU6 6L6 5678	Each of the electron tubes should test above the minimum requirements listed for its type in the test data book
3	None	POWER ON BIAS 0 SHUNT 0 FUNCTION SWITCH 1 Selector switches FILAMENT Left H Right S GRID 5 PLATE 3 SCREEN 4 CATHODE 6 SUPPRESSOR 8	Using the test lead as shown in C, figure 39, make each of the following connections in turn Rotate the FUNCTION SWITCH through all of the SHORTS positions (for each set of connections) Note and compare the positions of the FUNCTION SWITCH in which the SHORTS lamp lights with the positions listed in the performance standard column	SHORTS lamp should light at each of the following positions of the FUNCTION SWITCH
			<p><i>a</i> Connect pins 4 and 8</p> <p><i>b</i> Connect pins 5 and 6</p> <p><i>c</i> Connect pins 2 and 3</p> <p><i>d</i> Connect pins 2 and 5</p> <p><i>e</i> Connect pins 2 and 4</p> <p><i>f</i> Connect pins 3 and 8</p> <p><i>g</i> Connect pins 5 and 8</p> <p><i>h</i> Connect pins 4 and 5</p> <p><i>i</i> Connect pins 3 and 4</p> <p><i>j</i> Connect pins 2 and 8</p> <p><i>k</i> Connect pins 2 and 6</p> <p><i>l</i> Connect pins 3 and 5.</p>	<p><i>a</i> All positions</p> <p><i>b</i> 1, 2, 3, and 5</p> <p><i>c</i> 1, 2, 4, and 5</p> <p><i>d</i> 1, 2, and 5</p> <p><i>e</i> 1, 3, 4, and 5</p> <p><i>f</i> 1, 4, and 5</p> <p><i>g</i> 1 and 5</p> <p><i>h</i> 2, 3, and 4</p> <p><i>i</i> 2 and 3</p> <p><i>j</i> 2</p> <p><i>k</i> 3</p> <p><i>l</i> 4</p>

APPENDIX REFERENCES

<p>Following is a list of applicable references available to the field and depot maintenance repairman of Test Set, Electron Tube TV-7(*)/U:</p> <p>DA Pam 310-4</p>	<p>Military Publications: Index of Technical Manuals, Technical Bulletins, Supply Bulletins, Lubrication Orders, and Modification Work Orders.</p>	<p>TM 11-5102</p> <p>TM 11-6132</p> <p>TM 11-5527</p> <p>TM 11-6640</p>	<p>Resistors, Decade ZM-16/U and ZM-16A/U.</p> <p>Voltmeter, Meter ME-30A/U and Voltmeters, Electronic ME-30B/U and ME-30C/U.</p> <p>Multimeters TS-352/U, TS-352A/U, and TS-352B/U.</p> <p>Electric Light Assembly MX-1292/PAQ.</p>
<p>MWO 6625-274-35/1</p>	<p>Modification of Electronic Tube Test Set TV-7/U to Enable Proper Short Test at Line Frequencies Higher Than 60 Cps.</p>	<p>TM 11-6625-274-12</p>	<p>Operator's and Organizational Maintenance Manual, Test Sets, Electron Tube TV-7/U, TV-7A/U, TV-7B/U, and TV-7D/U.</p>
<p>NAVSHIPS 91798</p>	<p>Tube Socket Adapter Kit MX-1258/U for General Electronics Use.</p>	<p>TM 11-6625-274-20P</p>	<p>Organizational Maintenance Repair Parts and Special Tools List and Maintenance Allocation Chart for Test Sets, Electron Tube TV-7/U, TV-7A/U, TV-7B/U, and TV-7D/U.</p>
<p>TA 11-17</p>	<p>Signal Field Maintenance Shops.</p>		
<p>TA 11-100 (11-17)</p>	<p>Allowances of Signal Corps Expendable Supplies for Signal Field Maintenance Shops.</p>	<p>TM 11-6625-274-35P</p>	<p>Field and Depot Maintenance Repair Parts and Special Tools List for Test Sets, Electron Tube TV-7/U, TV-2A/U, TV-2B/U, and TV-2D/U.</p>
<p>TM 11-2661</p>	<p>Electron Tube Test Sets TV-2/U, TV-2A/U, and TV-2B/U.</p>		

By Order of *Wilber M. Brucker*, Secretary of the Army:

L. L. LEMNITZER,
General, United States Army,
Chief of Staff.

Official:

R. V. LEE,
Major General, United States Army,
The Adjutant General.

Distribution:

Active Army:

To be distributed in accordance with DA Form 12-7 requirements for TM 11 Series (UNCL), plus the following additional formula:

USASA (1)	11-39
CNGB (1)	11-45
Def Atomic Spt Agcy (5)	11-46
Tech Stf, DA (1) except	11-47
CSigO (18)	11-55
USA Abn & Elct Bd (1)	11-56
USA ATB (1)	11-57
US ARADCOM (2)	11-58
US ARADCOM Rgn (2)	11-95
MDW (1)	11-96
Seventh, US Army (5)	11-97
EUSA (6)	11-98
corps (2)	11-99
Mil Msn (2)	11-117
JBUSMC (2)	11-155
Units org under the fol TOE: (2 copies	11-166
each)	11-157
11-5	11-168
11-6	11-500 (AA-AE)
11-7	11-665
11-8	11-557
11-15	11-558
11-16	11-587
11-17	11-592
11-18	11-597
11-37	11-608
11-38	

NC: State AG (3); Units — Same as Active Army except allowance is one copy. to each unit.

USAR: None.

For explanation of abbreviations used see AR 320-50.

* U.S. GOVERNMENT PRINTING OFFICE : 1993 O- 342-421 (80985)

