

Mullard



technical handbook

Book 2

Electronic tubes

Part 2c

**Vidicon and Newvicon camera tubes
and deflection units**

1987

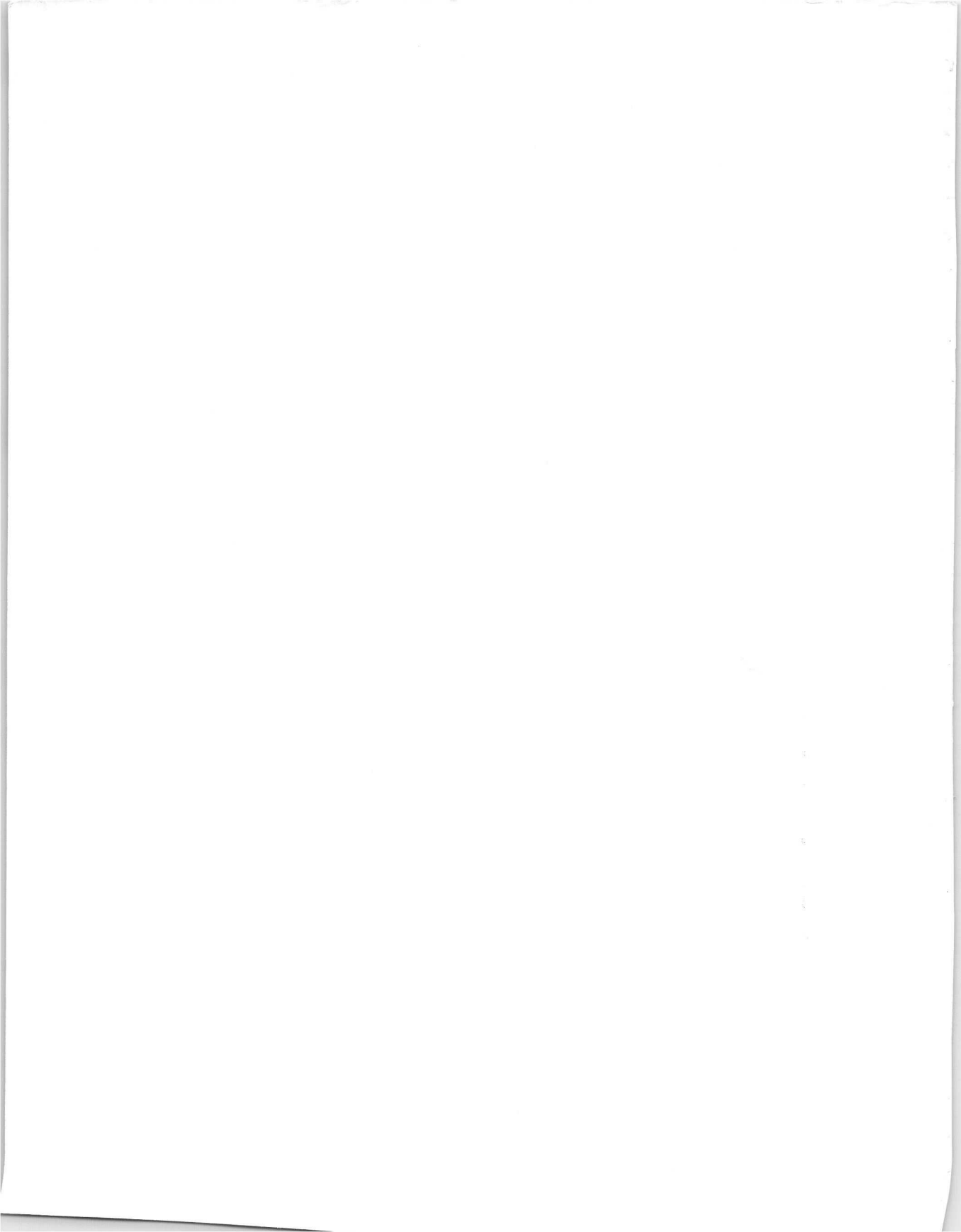



Book 2 Part 2c

Electronic tubes

Vidicon and Newvicon camera tubes and deflection units

MULLARD LTD., MULLARD HOUSE, TORRINGTON PLACE,
LONDON, WC1E 7HD

Telephone 01-580 6633

Telex: 264341

© Mullard Limited, April 1987

This information is furnished for guidance, with no guarantee as to its accuracy or completeness; its publication conveys no licence under any patent or other right, and the publisher does not assume liability for any consequence of its use; specifications are subject to change without notice; it is not to be reproduced in any way, in whole or in part, without the written consent of the publisher.

**VIDICON AND NEWVICON CAMERA TUBES
AND DEFLECTION UNITS**

	<i>page</i>
Vidicon tubes	
Survey and type selection	4
General operational notes	5
Device data.	9
Newvicon tubes	
Survey and type selection	76
General operational notes	77
Device data.	81
Deflection units	
Device data.	155
Index of type numbers.	179

THE HISTORY OF THE UNITED STATES

OF THE UNITED STATES OF AMERICA

The history of the United States is a story of growth and change. From the first settlers to the present day, the nation has expanded its territory and diversified its population. The early years were marked by struggle and hardship, but the spirit of independence and freedom prevailed. The American Revolution was a turning point in the nation's history, leading to the establishment of a new government based on the principles of liberty and justice for all. The years following the Revolution were a period of rapid growth and development. The nation expanded westward, and the economy flourished. The American Civil War was a defining moment in the nation's history, leading to the abolition of slavery and the strengthening of the Union. The years following the Civil War were a period of reconstruction and progress. The nation continued to grow and develop, and the American dream became a reality for many. The history of the United States is a story of resilience and achievement. Despite the challenges and hardships, the nation has persevered and thrived. The American spirit of freedom and independence continues to inspire and guide the nation today.

The American dream is a powerful force that has driven the nation forward. It is the belief that anyone, regardless of their background or circumstances, can achieve success and prosperity through hard work and determination. The American dream is a cornerstone of the nation's identity and a source of inspiration for millions of people. The history of the United States is a testament to the power of the American dream. From the early settlers to the present day, the nation has achieved remarkable success and progress. The American dream is a dream that has never been fully realized, but it continues to inspire and guide the nation today. The American dream is a dream that is worth fighting for. It is a dream that is worth believing in. The American dream is a dream that is worth living for.

The American dream is a dream that is worth fighting for. It is a dream that is worth believing in. The American dream is a dream that is worth living for. The American dream is a dream that is worth pursuing. The American dream is a dream that is worth striving for. The American dream is a dream that is worth reaching for. The American dream is a dream that is worth achieving. The American dream is a dream that is worth celebrating. The American dream is a dream that is worth sharing. The American dream is a dream that is worth passing on. The American dream is a dream that is worth living for. The American dream is a dream that is worth believing in. The American dream is a dream that is worth fighting for. The American dream is a dream that is worth pursuing. The American dream is a dream that is worth striving for. The American dream is a dream that is worth reaching for. The American dream is a dream that is worth achieving. The American dream is a dream that is worth celebrating. The American dream is a dream that is worth sharing. The American dream is a dream that is worth passing on.

VIDICON TUBES

Model	Gain	Resolution	Size	Notes
1000	100	1000	1.5"	
1001	100	1000	1.5"	
1002	100	1000	1.5"	
1003	100	1000	1.5"	
1004	100	1000	1.5"	
1005	100	1000	1.5"	
1006	100	1000	1.5"	
1007	100	1000	1.5"	
1008	100	1000	1.5"	
1009	100	1000	1.5"	
1010	100	1000	1.5"	
1011	100	1000	1.5"	
1012	100	1000	1.5"	
1013	100	1000	1.5"	
1014	100	1000	1.5"	
1015	100	1000	1.5"	
1016	100	1000	1.5"	
1017	100	1000	1.5"	
1018	100	1000	1.5"	
1019	100	1000	1.5"	
1020	100	1000	1.5"	
1021	100	1000	1.5"	
1022	100	1000	1.5"	
1023	100	1000	1.5"	
1024	100	1000	1.5"	
1025	100	1000	1.5"	
1026	100	1000	1.5"	
1027	100	1000	1.5"	
1028	100	1000	1.5"	
1029	100	1000	1.5"	
1030	100	1000	1.5"	
1031	100	1000	1.5"	
1032	100	1000	1.5"	
1033	100	1000	1.5"	
1034	100	1000	1.5"	
1035	100	1000	1.5"	
1036	100	1000	1.5"	
1037	100	1000	1.5"	
1038	100	1000	1.5"	
1039	100	1000	1.5"	
1040	100	1000	1.5"	
1041	100	1000	1.5"	
1042	100	1000	1.5"	
1043	100	1000	1.5"	
1044	100	1000	1.5"	
1045	100	1000	1.5"	
1046	100	1000	1.5"	
1047	100	1000	1.5"	
1048	100	1000	1.5"	
1049	100	1000	1.5"	
1050	100	1000	1.5"	
1051	100	1000	1.5"	
1052	100	1000	1.5"	
1053	100	1000	1.5"	
1054	100	1000	1.5"	
1055	100	1000	1.5"	
1056	100	1000	1.5"	
1057	100	1000	1.5"	
1058	100	1000	1.5"	
1059	100	1000	1.5"	
1060	100	1000	1.5"	
1061	100	1000	1.5"	
1062	100	1000	1.5"	
1063	100	1000	1.5"	
1064	100	1000	1.5"	
1065	100	1000	1.5"	
1066	100	1000	1.5"	
1067	100	1000	1.5"	
1068	100	1000	1.5"	
1069	100	1000	1.5"	
1070	100	1000	1.5"	
1071	100	1000	1.5"	
1072	100	1000	1.5"	
1073	100	1000	1.5"	
1074	100	1000	1.5"	
1075	100	1000	1.5"	
1076	100	1000	1.5"	
1077	100	1000	1.5"	
1078	100	1000	1.5"	
1079	100	1000	1.5"	
1080	100	1000	1.5"	
1081	100	1000	1.5"	
1082	100	1000	1.5"	
1083	100	1000	1.5"	
1084	100	1000	1.5"	
1085	100	1000	1.5"	
1086	100	1000	1.5"	
1087	100	1000	1.5"	
1088	100	1000	1.5"	
1089	100	1000	1.5"	
1090	100	1000	1.5"	
1091	100	1000	1.5"	
1092	100	1000	1.5"	
1093	100	1000	1.5"	
1094	100	1000	1.5"	
1095	100	1000	1.5"	
1096	100	1000	1.5"	
1097	100	1000	1.5"	
1098	100	1000	1.5"	
1099	100	1000	1.5"	
1100	100	1000	1.5"	

VIDICON TUBES

SURVEY VIDICON TUBES

1 inch - magnetic focusing and deflection

All types 95 mA; 6,3 V

type	mesh	photo-conductive layer	quality grade			applications		
			Br	HI	Ind	Med	MS	GP
XQ1031	I	A	●	●	●	●	●	●
XQ1032	I	A	●	●	●	●	●	●
XQ1240	S	A	●	●	●	●	●	●
XQ1241	S	A	●	●	●	●	●	●
XQ1280	S	B				●	●	●
XQ1285*	S	B				●	●	●

* Fibre-optic faceplate

2/3 inch - magnetic focusing and deflection

XQ1270	I	A	●	●	●	●	●	110 mA; 6,3 V
XQ1271	S	A	●	●	●	●	●	

2/3 inch - electrostatic focusing and magnetic deflection

XQ1272	S	A	●	●	●	●	●	** Bi-potential electrostatic focusing lens
XQ1590**	S	A	●	●	●	●	●	

1/2 inch - electrostatic focusing and magnetic deflection

XQ1600	S	A	●	●	●	●	107 mA; 2,8 V
--------	---	---	---	---	---	---	---------------

Accessories for Vidicon tubes

type	deflection (and focusing) coil unit	sockets
XQ1031, XQ1032 XQ1240, XQ1241 XQ1280, XQ1285	AT1102/01, KV9G AT1116S or equivalent	56098 or equivalent
XQ1270, XQ1271 XQ1272, XQ1590 XQ1600	KV12S or equivalent KV19G or equivalent KV29E or equivalent	56098 or equivalent

Abbreviations used in the tables

I = integral mesh
S = separate mesh
A = standard layer
B = layer with peak response at approx. 475 nm
Br = for black and white and colour broadcast cameras, telecine

HI = for high-quality black and white and colour cameras in sub-broadcast, medical, educational and industrial applications
Ind = for black and white and colour cameras in non-critical industrial applications
Med = in medical or industrial X-ray equipment, coupled with an image intensifier

MS = in cameras for military, surveillance, and scientific applications
GP = general purpose tube for low-cost cameras

GENERAL OPERATIONAL NOTES

1 PROPERTIES OF THE VIDICON PHOTOCONDUCTIVE LAYER

The vidicon photoconductive layer consists mainly of antimony trisulphide (Sb_2S_3). It is built up of a number (2 to 4) of sublayers. Its properties are dependent on the antimony-sulphur ratios and the porosities of the sublayers.

In the vidicons, described in this Data Handbook, two layer variants are found, denominated layer A and layer B. The standard vidicons intended e.g. for industrial and educational applications contain layer A., the vidicons for medical applications in conjunction with X-ray image intensifiers contain layer B.

1.1 Sensitivity

The light transfer characteristic of a vidicon is not linear and depends strongly on the target voltage. A single value for the sensitivity can therefore not be given, but a series of transfer curves is required with e.g. the dark current as a parameter.

For a 1-inch size vidicon with layer A typical light transfer characteristics for three dark current settings are given in Fig. 1.

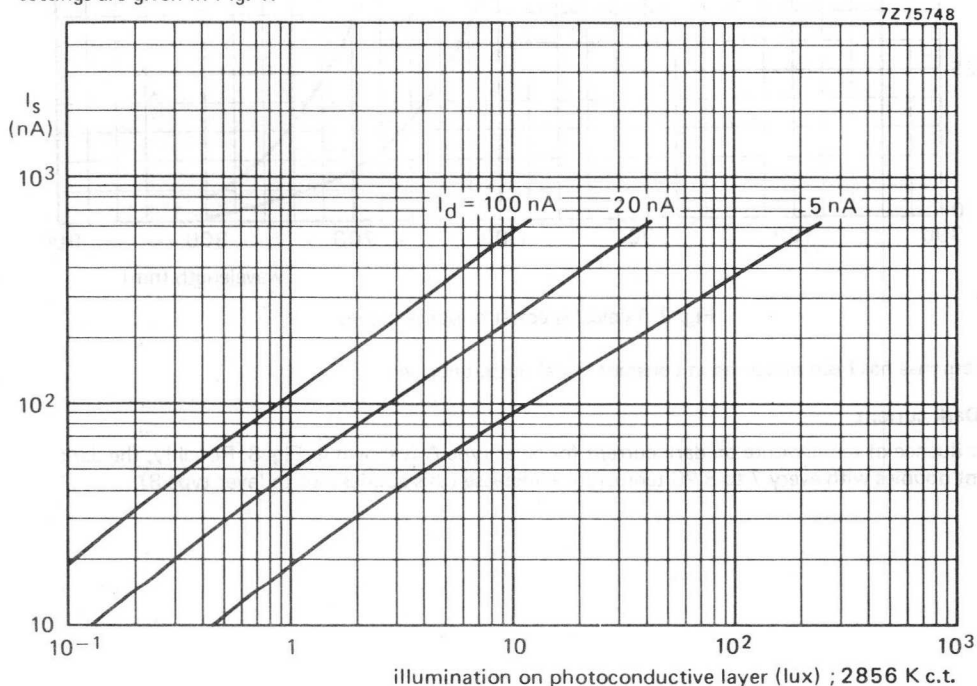

Fig. 1 Typical light transfer characteristics for 1-inch size vidicons with layer A.

(Note: A comparison can be made with Plumbicon tubes: at an input light level on the layer of approx. 8 lx the signal current in nA is equal to the sensitivity in $\mu A/lumen$.)

Vidicons with type B layer are intended mainly for use in X-ray equipment, coupled to an X-ray image intensifier equipped with a P11 or P20 output phosphor. Detailed information on the light transfer characteristics in such situations is found in the data sheets for these tubes: the XQ1280 with plain glass faceplate and the XQ1285 with fibre-optic faceplate.

1.2 Spectral response

Typical relative spectral responses of the layers type A and type B are found in Fig. 2.

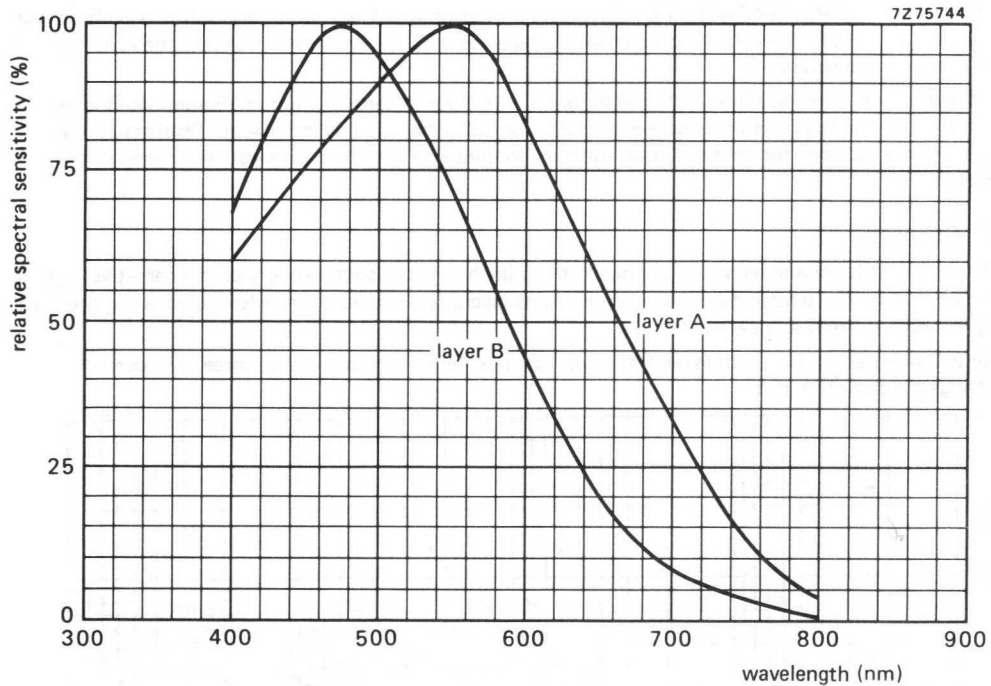

Fig. 2 Typical spectral response curves.

The response has been measured at constant signal output current.

1.3 Dark current

The influence of temperature on dark current for layer type A is shown in Fig. 3. Roughly, the dark current doubles with every 7 to 8 °C temperature increase (this applies also to layer type B).

1.4 Resolution

The photoconductive layer in a vidicon being very thin (2 to 3 μm), gun construction and operating conditions are the determining factors for resolution. As an example, Fig. 4 shows typical modulation transfer characteristics for the 1-inch tube XQ1280 in the low voltage mode and in the high voltage mode (scanning are 9,6 mm x 12,8 mm).

1.5 Lag

Lag is dependent on signal current, dark current and temperature. At low signal currents discharge lag dominates whereas at high signal currents photoconductive lag is preponderant. A typical residual signal level, 200 ms after cessation of an illumination giving a signal current of 200 nA, for the 1-inch vidicon type XQ1240 with layer type A, at a dark current of 20 nA is 8% (16 nA).

2 EQUIPMENT DESIGN AND OPERATING CONDITIONS

(See also General Operational Notes Plumbicon Camera tubes.)

The signal electrode voltage should be limited to such a value that the peak dark current does not exceed 250 nA for tubes with layer A and 100 nA for tubes with layer B.

This is of particular importance for the design and adjustment of vidicon cameras with automatically controlled sensitivity (automatic control of the signal-electrode voltage).

Operation of vidicons at excess dark current may result in damage to the photoconductive target and hence shorten the tube life.

The temperature of the faceplate should never exceed 80 °C, neither during operation nor storage.

Operation at a faceplate temperature of 25 to 30 °C is recommended.

The temperature of the faceplate is determined by the heating effects of the environment, the associated components, the incident illumination and, to a minor extent, by the tube itself.

Under difficult environmental conditions a flow of cooling air directed at the faceplate is recommended. Under conditions of high heat irradiation, an infrared filter between object and camera lens should be used.

A cathode heating time of at least a minute is advised before drawing cathode current. During prolonged idle periods, (days or weeks) gas pressure may very slowly build up in the tube due to residual gas molecules emerging from the electrodes and the glass wall. There is then a slight risk that the pressure is sufficiently high to cause cathode damage by ion bombardment if cathode current is drawn immediately after switching on the camera.

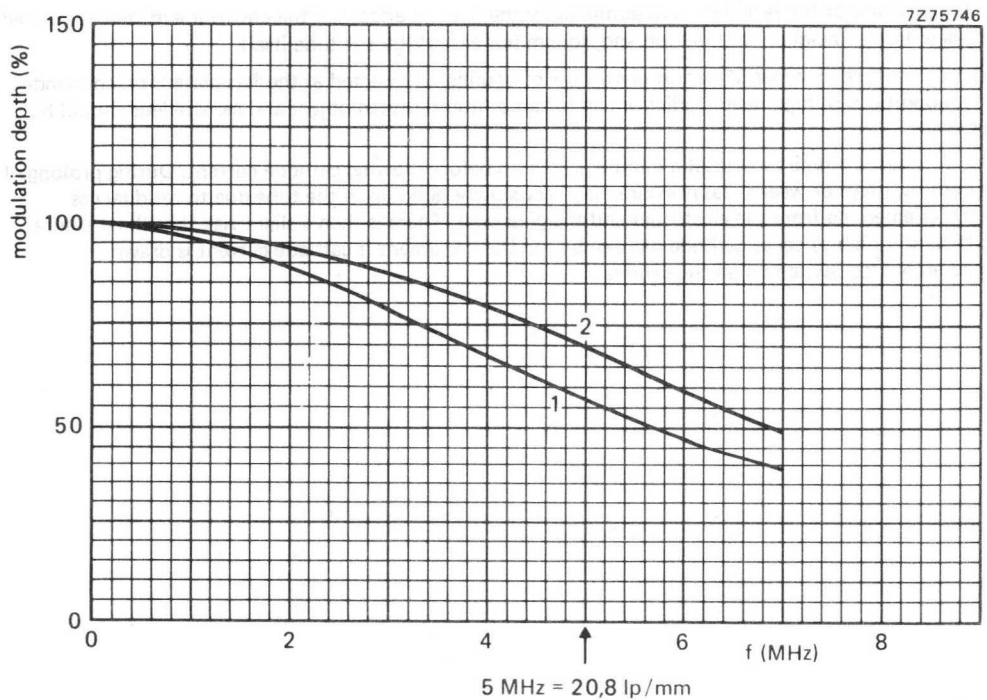
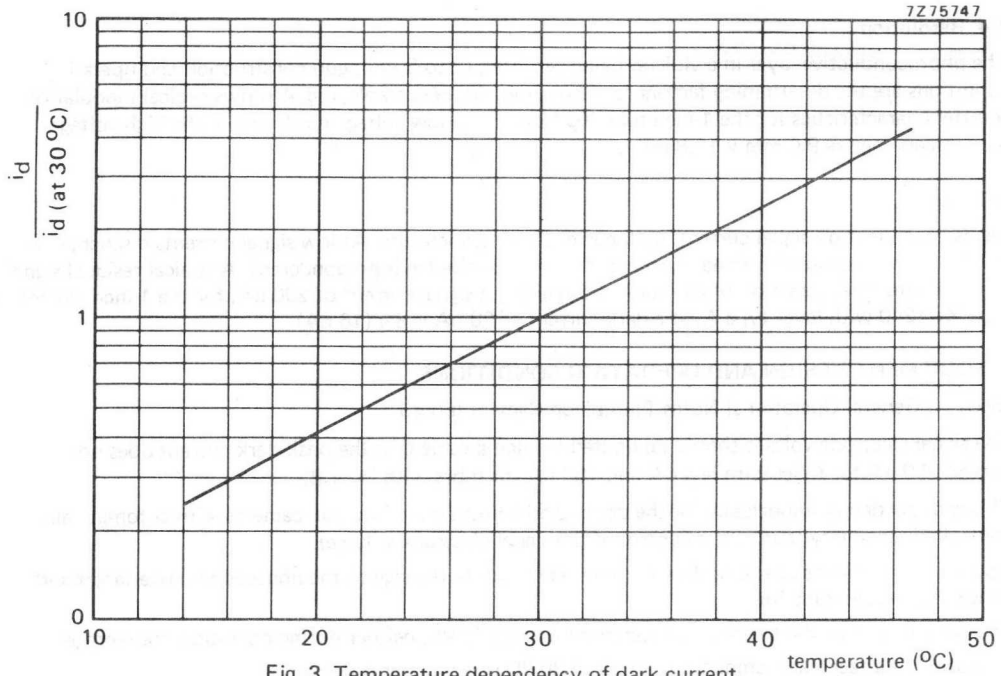

Fig. 4 Typical modulation transfer characteristics for XQ1280.
 Curve 1: $V_{g3} = 375 \text{ V}$, $V_{g4} = 600 \text{ V}$; curve 2: $V_{g3} = 600 \text{ V}$, $V_{g4} = 960 \text{ V}$.

CAMERA TUBES

Vidicon television camera tubes with low heater consumption, integral mesh construction, magnetic focusing, magnetic deflection, short length (130 mm, 5 in), and 25,9 mm (1 in) diameter.

QUICK REFERENCE DATA

Integral mesh	
Focusing	magnetic
Deflection	magnetic
Diameter	25,9 mm (1 in)
Length	130 mm (5 in)
Heater	6,3 V, 95 mA
Limiting resolution	600 TV lines

The electrical and mechanical properties of the two types are essentially identical, the main difference being found in the degree of freedom from blemishes of the photoconductive layers.

XQ1031 – intended for use in industrial and broadcast applications in which a high standard of performance is required.

XQ1032 – general purpose tube for less critical industrial applications, experiments, amateur use etc.

OPTICAL

Diagonal of quality rectangle on photoconductive layer (aspect ratio 3 : 4) 16 mm

Orientation of image on photoconductive layer:

The direction of the horizontal scan should be essentially parallel to the plane passing through the longitudinal tube axis and the short index pin.

Photoconductive layer	type A
Spectral response, max. response at	approx. 550 nm
Faceplate thickness	2,5 mm
refractive index	1,487

HEATING

Indirect by a.c. or d.c.; parallel or series supply

Heater voltage	V_f	6,3 V \pm 10%
Heater current at $V_f = 6,3$ V	I_f	95 mA

When the tube is used in a series heater chain, the heater voltage must not exceed 9,5 V r.m.s. when the supply is switched on.

XQ1031
XQ1032

CAPACITANCES

Signal electrode to all

$$C_{as} \approx 4,6 \text{ pF}$$

This capacitance, which effectively is the output impedance of the tube, increases when the tube is inserted into the deflection and focusing coil unit.

MECHANICAL DATA

Dimensions in mm

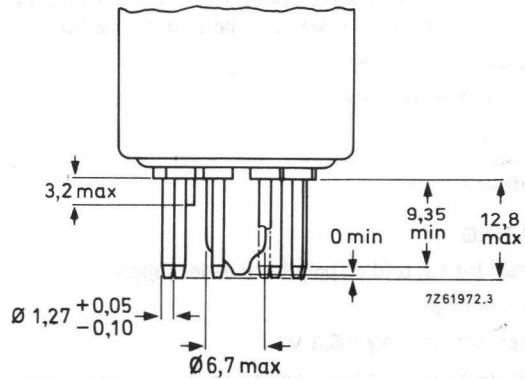
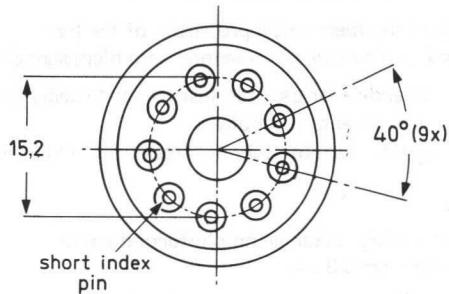
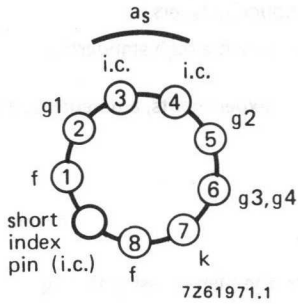
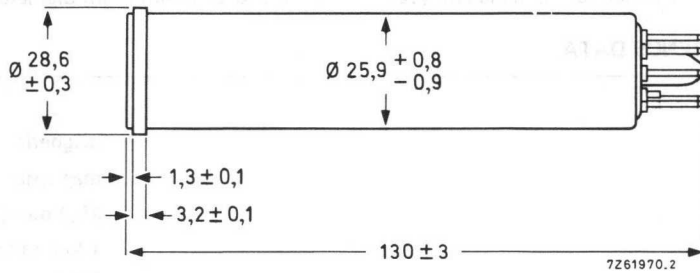

Base: JEDEC no. E8-11

Mounting position: any

Net mass: $\approx 57 \text{ g}$

ACCESSORIES

Socket	type 56098 or equivalent
Deflection and focusing coil unit	AT1102/01, KV9G or equivalent

DEFLECTION magnetic**FOCUSING** magnetic**LIMITING VALUES**

(Absolute maximum rating system) for scanned area of 9,6 mm x 12,8 mm (3/8 in x 1/2 in)

"Full-size scanning", i.e. scanning of a 9,6 mm x 12,8 mm area of the photoconductive layer should always be applied. Underscanning, i.e. scanning of an area less than 9,6 mm x 12,8 mm, may cause permanent damage to the specified full-size area.

Signal-electrode voltage	V_{as}	max.	100 V
Grid 4 voltage and grid 3 voltage	$V_{g4, g3}$	max.	750 V
Grid 2 voltage	V_{g2}	max.	750 V
Grid 1 voltage, negative	$-V_{g1}$	max.	300 V
positive	V_{g1}	max.	0 V
Cathode-to-heater voltage, peak positive	V_{kfp}	max.	125 V
peak negative	$-V_{kfp}$	max.	10 V
Dark current, peak	I_{darkp}	max.	250 nA
Output current, peak	I_{asp}	max.	550 nA *
Faceplate illumination	E	max.	10 000 lx
Faceplate temperature, storage and operation	T	max.	70 °C **
Cathode heating time before drawing cathode current	t_h	min.	1 min

* Video amplifiers should be capable of handling signal-electrode currents of this magnitude without overloading the amplifier or distorting the picture.

** Under difficult environmental conditions a flow of cooling air directed at the faceplate is recommended. When televising flames and furnaces appropriate infrared absorbing filters should be used.

OPERATING CONDITIONS AND PERFORMANCE

notes

For a scanned area of 9,6 mm x 12,8 mm and a faceplate temperature of 25 to 35 °C.

CONDITIONS

Grid 4 and grid 3 (beam focus electrode) voltage	$V_{g4,g3}$	250 to 300 V	1
Grid 2 (accelerator) voltage	V_{g2}	300 V	
Grid 1 voltage for picture cut-off (no blanking applied)	V_{g1}	-100 to -45 V	
Blanking voltage, peak-to-peak			
when applied to grid 1		75 V	
when applied to the cathode		20 V	
Flux density at centre of focusing coil		4,0 mT	
Flux density of adjustable alignment coils		0 to 0,4 mT	

PERFORMANCE

		min.	typ.	max.	
Signal electrode voltage for dark current of 20 nA	V_{as}	10	30	V	
Signal current					
faceplate illumination 10 lx					
c.t. 2856 K, dark current 20 nA	I_s	150	240	nA	
Decay: residual signal current					
60 ms after cessation of the illumination					
(c.t. 2856 K, initial signal current 200 nA, dark current 20 nA)			21	%	
Limiting resolution, at picture centre		500	600	TV lines	2
at picture corners		350	450	TV lines	2
Average γ of transfer characteristic for signal currents between 20 and 200 nA		0,55	0,74	0,85	
Spurious signals (spot and blemishes)					3

Notes see next page.

NOTES

- Resolution decreases with decreasing grid 3 and 4 voltages. In general grids 3 and 4 should be operated above 250 V.
- On EIA resolution test chart, faceplate illumination adjusted for peak signal current of 200 nA and dark current of 20 nA.
- Conditions:

The camera focused on a uniformly illuminated two-zone test pattern, the diameter of the centre zone (1) being equal to the raster height. Zone (2) being defined as the remainder of the scanned area. Signal electrode voltage adjusted for a dark current of 20 nA, illumination on target (c.t. = 2856 K) adjusted to provide a signal current of 200 nA. Beam current adjusted for correct stabilization.

Scanning amplitudes of the monitor adjusted to obtain a raster with an aspect ratio of 3 : 4.

Monitor set-up and contrast control adjusted for faint raster when lens of camera is capped, and for non-blooming bright raster when lens of camera is uncapped.

Under the above conditions the number and size of the spots visible in the monitor picture will not exceed the limits stated below. Both black and white spots must be counted. Only white and black spots with contrasts $\geq 50\%$ and $\geq 100\%$ respectively (of peak white signal) are taken into account.

XQ1031

Spot size in % of raster height	Maximum number of spots	
	zone 1	zone 2
> 0,8	none	none
$\leq 0,8$ to 0,6	none	none
$\leq 0,6$ to 0,2	1	2
$\leq 0,2$	*	*
total (max.)	2	

XQ1032

Spot size in % of raster height	Maximum number of spots	
	zone 1	zone 2
> 0,8	none	none
$\leq 0,8$ to 0,6	none	1
$\leq 0,6$ to 0,2	2	3
$\leq 0,2$	*	*
total (max.)	4	

* Do not count spots of this size unless concentration causes a smudgy appearance.

- Minimum separation between any 2 spots greater than 0,4% of raster height is limited to a distance equivalent to 3% of raster height.
- Tubes are rejected for smudge, lines, streaks, mottled, grainy, or uneven background having contrasts $> 50\%$.

Faint, illegible text, possibly bleed-through from the reverse side of the page.

Faint, illegible text, possibly bleed-through from the reverse side of the page.

Faint, illegible text, possibly bleed-through from the reverse side of the page.

Faint, illegible text, possibly bleed-through from the reverse side of the page.

CAMERA TUBES

Vidicon television camera tubes with low heater consumption, separate mesh construction, magnetic focusing, magnetic deflection and 25,9 mm (1 in) diameter intended for use in black-and-white and colour television cameras in industrial, medical and broadcast applications.

QUICK REFERENCE DATA

Separate mesh	
Focusing	magnetic
Deflection	magnetic
Diameter	25,9 mm (1 in)
Length	159 mm (6¼ in)
Heater	6,3 V, 95 mA
Limiting resolution	800 TV lines

The electrical and mechanical properties of the two types are essentially identical, the differences being found in the degree of freedom from blemishes of the photoconductive layers, in the sensitivity and the signal electrode voltage range.

XQ1240 — intended for use in industrial, medical and broadcast applications in which a high standard of performance is required.

XQ1241 — general purpose tube for less critical industrial applications, experiments, amateur use etc.

OPTICAL

Diagonal of quality rectangle on photoconductive layer
(aspect ratio 3 : 4) 16 mm

Orientation of image on photoconductive layer:

The direction of the horizontal scan should be essentially parallel to the plane passing through the short index pin and the longitudinal axis of the tube.

Photoconductive layer	type A
Spectral response, max. response at	approx. 550 nm
Faceplate thickness	2,5 mm
refractive index	1,487

HEATING

Indirect by a.c. or d.c.; parallel or series supply

Heater voltage	V_f	6,3 V \pm 10%
Heater current at $V_f = 6,3$ V	I_f	95 mA

When the tube is used in a series heater chain, the heater voltage must not exceed 9,5 V r.m.s. when the supply is switched on.

XQ1240
XQ1241

CAPACITANCES

Signal electrode to all

$$C_{as} \approx 4,6 \text{ pF}$$

This capacitance, which effectively is the output impedance of the tube, increases when the tube is inserted into the deflection and focusing coil unit.

MECHANICAL DATA

Dimensions in mm

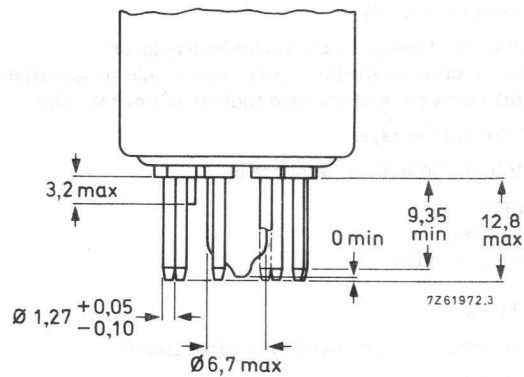
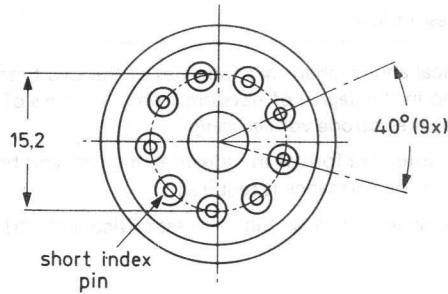
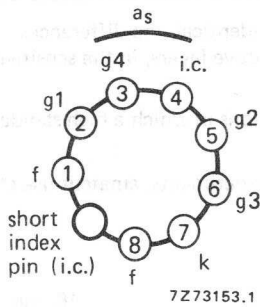
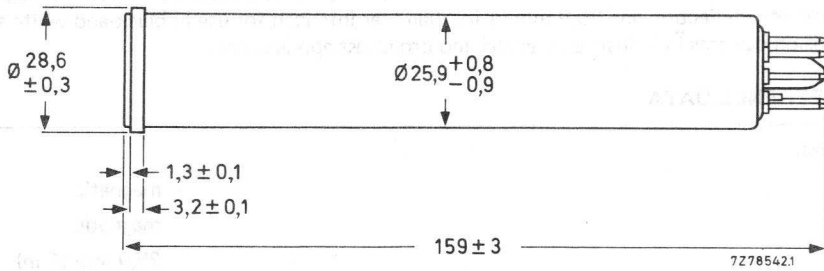

Base: JEDEC no. E8-11

Mounting position: any

Net mass: $\approx 70 \text{ g}$

ACCESSORIES

Socket	type 56098 or equivalent
Deflection and focusing coil unit	AT1102/01, KV9G or equivalent

DEFLECTION magnetic

FOCUSING magnetic

LIMITING VALUES

(Absolute maximum rating system) for scanned area of 9,6 mm x 12,8 mm (3/8 in x 1/2 in)

"Full-size scanning", i.e. scanning of a 9,6 mm x 12,8 mm area of the photoconductive layer should always be applied. Underscanning, i.e. scanning of an area less than 9,6 mm x 12,8 mm, may cause permanent damage to the specified full-size area.

Signal-electrode voltage	V_{as}	max.	100 V
Grid 4 voltage	V_{g4}	max.	1000 V
Grid 3 voltage	V_{g3}	max.	1000 V
Grid 2 voltage	V_{g2}	max.	750 V
Grid 1 voltage,			
negative	$-V_{g1}$	max.	300 V
positive	V_{g1}	max.	0 V
Cathode-to-heater voltage,			
peak positive	V_{kfp}	max.	125 V
peak negative	$-V_{kfp}$	max.	10 V
Dark current, peak	I_{darkp}	max.	250 nA
Output current, peak	I_{asp}	max.	550 nA*
Faceplate illumination	E	max.	10 000 lx
Faceplate temperature, storage and operation	T	max.	70 °C**
Cathode heating time before drawing cathode current	t_h	min.	1 min

* Video amplifiers should be capable of handling signal-electrode currents of this magnitude without overloading.

** Under difficult environmental conditions a flow of cooling air directed at the faceplate is recommended. When televising flames and furnaces, appropriate infrared absorbing filters should be used.

OPERATING CONDITIONS AND PERFORMANCE

notes

For a scanned area of 9,6 mm x 12,8 mm and a faceplate temperature of 25 to 35 °C.

CONDITIONS

Grid 4 voltage	V_{g4}	500 V	1
Grid 3 (focusing electrode) voltage	V_{g3}	300 V	2
Grid 2 (accelerator) voltage	V_{g2}	300 V	
Grid 1 voltage for picture cut-off (no blanking applied)	V_{g1}	-100 to -45 V	
Blanking voltage, peak-to-peak			
when applied to grid 1		75 V	
when applied to cathode		20 V	
Flux density at centre of focusing coil		3,8 to 4,4 mT	
Flux density of adjustable alignment coils		0 to 0,4 mT	

PERFORMANCE

		min.	typ.	max.	
Signal electrode voltage for dark current of 20 nA					
XQ1240	V_{as}	30	45	60 V	
XQ1241	V_{as}	10	30	V	
Signal current					
faceplate illumination 10 lx, c.t. 2856 K, dark current 20 nA					
XQ1240	I_s	180	300	nA	
XQ1241	I_s	150	240	nA	
Decay: residual signal current					
60 ms after cessation of the illumination (c.t. 2856 K, initial signal current 200 nA, dark current 20 nA)			21	%	
Limiting resolution, at picture centre		650	800	TV lines	3
at picture corners		400	500	TV lines	3
Average γ of transfer characteristic for signal currents between 20 and 200 nA		0,55	0,74	0,85	
Spurious signals (spots and blemishes)					4

Notes see next page.

NOTES

- Grid 4 voltage must always be higher than grid 3 voltage. The recommended ratio of grid 4 to grid 3 voltage, for best geometry and most uniform signal output depends upon the type of coil used and will be 5 : 3 for the recommended types (see "Accessories").
- Resolution decreases with decreasing grid 3 voltage. In general grid 3 should be operated above 250 V.
- On EIA resolution test chart, faceplate illumination adjusted for peak signal current of 200 nA and dark current of 20 nA.
- Conditions:

The camera focused on a uniformly illuminated two-zone test pattern, the diameter of the centre zone (1) being equal to the raster height. Zone (2) being defined as the remainder of the scanned area. Signal electrode voltage adjusted for a dark current of 20 nA, illumination on the target (c.t. = 2856 K) adjusted to provide a signal current of 200 nA. Beam current adjusted for correct stabilization.

Scanning amplitudes of the monitor adjusted to obtain a raster with an aspect ratio of 3 : 4.

Monitor set-up and contrast control adjusted for faint raster when lens of camera is capped, and for non-blooming bright raster when lens of camera is uncapped.

Black spots having a contrast $\geq 100\%$ ($\geq 10\%$ for XQ1240) and white spots having a contrast $\geq 50\%$ of peak white signal ($\geq 10\%$ for XQ1240) are fully counted.

Under the above conditions the number and size of the spots visible in the monitor picture will not exceed the limits stated below.

XQ1240

Spot size in % of raster height	Maximum number of spots	
	zone 1	zone 2
> 0,8	none	none
$\leq 0,8$ to 0,6	none	none
$\leq 0,6$ to 0,2	1	2
$\leq 0,2$	*	*
total (max.)	2	

XQ1241

Spot size in % of raster height	Maximum number of spots	
	zone 1	zone 2
> 0,8	none	none
$\leq 0,8$ to 0,6	none	1
$\leq 0,6$ to 0,2	2	3
$\leq 0,2$	*	*
total (max.)	4	

- * Do not count spots of this size unless concentration causes a smudgy appearance.
- Minimum separation between any two spots greater than 0,4% of raster height is limited to a distance equivalent to 3% of raster height.
 - Tubes are rejected for smudge, lines, streaks, mottled, grainy or uneven background having contrast ratios in excess of 10% (XQ1240) and 50% (XQ1241).

CAMERA TUBE

Small size vidicon television camera tube with low heater consumption, integral mesh construction, magnetic focusing and magnetic deflection. Overall length 108 mm (4 1/4 in) and diameter 17,7 mm (2/3 in).

The XQ1270 is intended for use in ultra compact TV cameras for industrial and consumer applications.

QUICK REFERENCE DATA

Integral mesh	
Focusing	magnetic
Deflection	magnetic
Diameter	17,7 mm
Length	max. 108 mm
Heater	6,3 V; 110 mA
Limiting resolution	500 TV lines

OPTICAL

Diagonal of quality rectangle on photoconductive layer (aspect ratio 3 : 4)	max.	11 mm
--	------	-------

Orientation of image on photoconductive layer:

The direction of the horizontal scan should be essentially parallel to the plane passing through pin 4 and the longitudinal axis of the tube.

Photoconductive layer		type A
Spectral response, max. response at	approx.	550 nm
Faceplate		
thickness		1,5 mm
refractive index		1,487

HEATING

Indirect by a.c. or d.c.; parallel or series supply

Heater voltage	V_f	$6,3 \text{ V} \pm 10\%$
Heater current at $V_f = 6,3 \text{ V}$	I_f	110 mA

When the tube is used in a series heater chain, the heater voltage must not exceed an r.m.s. value of 9,5 V when the supply is switched on.

CAPACITANCES

Signal electrode to all

$$C_{as} \approx 2 \text{ pF}$$

This capacitance, which is effectively the output impedance of the tube, increases when the tube is inserted into the deflection and focusing coil unit.

MECHANICAL DATA

Dimensions in mm

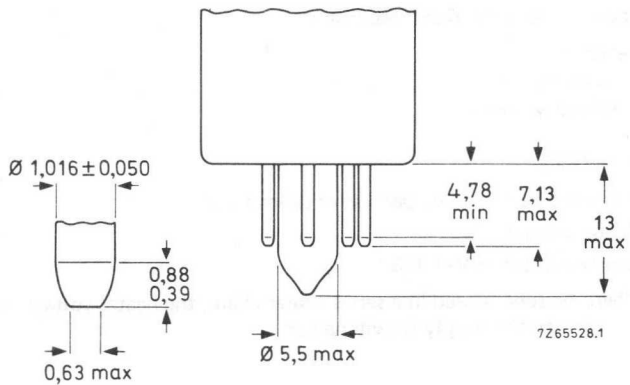
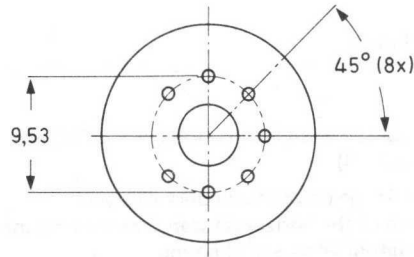
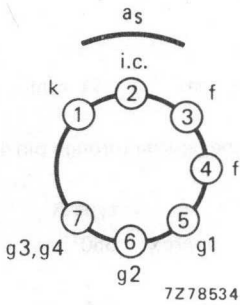
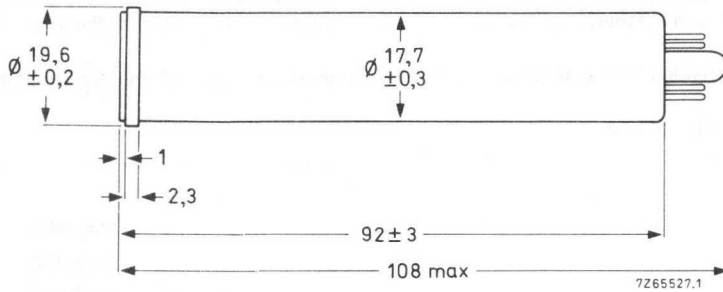

Base: JEDEC no. E7-91.

Mounting position: any

Net mass: $\approx 22 \text{ g}$

ACCESSORIES

Socket	special miniature 7-pin, type 56049 or equivalent
Deflection and focusing coil unit	KV12S or equivalent

DEFLECTION magnetic

FOCUSING magnetic

LIMITING VALUES

(Absolute maximum rating system) for scanned area of 6,6 mm x 8,8 mm.

"Full-size scanning" i.e. scanning of a 6,6 mm x 8,8 mm area of the photoconductive layer should always be applied. Underscanning, i.e. scanning of an area smaller than 6,6 mm x 8,8 mm, may cause permanent damage to the specified full-size area.

Signal electrode voltage	V_{as}	max.	80 V
Grid 4 and grid 3 voltage	$V_{g4,g3}$	max.	750 V
Grid 2 voltage	V_{g2}	max.	350 V
Grid 1 voltage, negative	$-V_{g1}$	max.	300 V
positive	V_{g1}	max.	0 V
Cathode-to-heater voltage, peak positive	V_{kfp}	max.	125 V
peak negative	$-V_{kfp}$	max.	10 V
Dark current, peak	I_{dp}	max.	150 nA
Output current, peak	I_{asp}	max.	500 nA*
Faceplate illumination	E	max.	10 000 lx
Faceplate temperature, storage and operation	T	max.	70 °C**
Cathode heating time before drawing cathode current	t_h	min.	1 min

* Video amplifiers should be capable of handling signal-electrode currents of this magnitude without overloading the amplifier or distorting the picture.

** Under difficult environmental conditions a flow of cooling air directed at the faceplate is recommended. When televising flames and furnaces, appropriate infra-red absorbing filters should be used.

OPERATING CONDITIONS AND PERFORMANCE

For a scanned area of 6,6 mm x 8,8 mm and a faceplate temperature of 25 to 35 °C.

CONDITIONS

			notes
Grid 4 and grid 3 (beam focus electrode) voltage	$V_{g4,g3}$	250 to 300 V	1
Grid 2 (accelerator) voltage	V_{g2}	300 V	
Grid 1 voltage for picture cut-off (no blanking applied)	V_{g1}	-80 to -20 V	
Blanking voltage, peak-to-peak			
when applied to grid 1		75 V	
when applied to the cathode		20 V	
Flux density at centre of focusing coil		5 mT	
Flux density of adjustable alignment magnets		0 to 0,4 mT	

PERFORMANCE

		min.	typ.	max.	
Signal electrode voltage for dark current of 20 nA	V_{as}	10	30	V	
Signal current					
faceplate illumination 10 lx					
c.t. 2856 K, dark current 20 nA	I_s	100	200	nA	
Decay: residual signal current					
60 ms after cessation of the illumination					
(c.t. 2856 K, initial signal current 200 nA, dark current 20 nA)			17	%	
Limiting resolution, at picture centre		400	500	TV lines	2
at picture corners		300	400	TV lines	
Average γ of transfer characteristic for signal currents between 20 and 200 nA (see Fig. 1)		0,55	0,74	0,85	
Spurious signals (spots and blemishes)					3

Notes see next page.

NOTES

- Resolution decreases with decreasing grid 3 and 4 voltages. In general grids 3 and 4 should be operated above 250 V.
- On EIA resolution test chart, faceplate illumination adjusted for peak signal current of 200 nA and dark current of 20 nA.
- Conditions:

The camera focused on a uniformly illuminated two-zone test pattern, the diameter of the centre zone (1) being equal to the raster height. Zone (2) being defined as the remainder of the scanned area. Signal electrode voltage adjusted for a dark current of 20 nA, illumination (c.t. 2856 K) adjusted to provide a signal current of 200 nA. Beam current adjusted for correct stabilization.

Scanning amplitudes of the monitor adjusted to obtain a raster aspect ratio of 3 : 4.

Monitor set-up and contrast control adjusted for faint raster when lens of camera is capped, and for non-blooming bright raster when lens of camera is uncapped.

Under the above conditions the number and size of the spots visible in the monitor picture will not exceed the limits stated below. Both black and white spots must be counted. Only white and black spots with contrasts $\geq 50\%$ and $\geq 100\%$ respectively (of peak white signal) are taken into account.

Spot size in % of raster height	Maximum number of spots	
	zone 1	zone 2
> 0,8	none	none
$\leq 0,8$ to 0,6	none	1
$\leq 0,6$ to 0,2	2	3
$\leq 0,2$	*	*
total (max.)	4	

- * Do not count spots of this size unless concentration causes a smudgy appearance.
- Minimum separation between any 2 spots greater than 0,4% of raster height is limited to a distance equivalent to 3% of raster height.
 - Tubes are rejected for smudge, lines, streaks, mottled, grainy or uneven background having contrasts $> 50\%$.

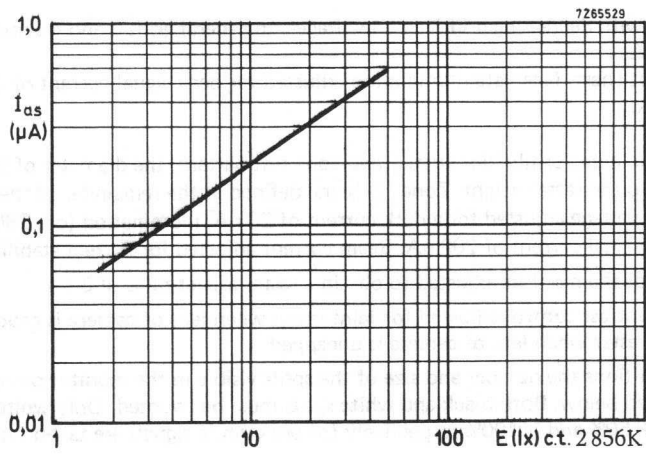

Fig. 1 Typical light transfer characteristic. Scanned area 6,6 mm x 8,8 mm. Faceplate temperature ≈ 30 °C.

CAMERA TUBE

Small size vidicon television camera tube with low heater consumption, separate mesh construction for improved resolution, magnetic focusing and magnetic deflection.

Overall length 108 mm (4¼ in) and diameter 17,7 mm (2/3 in).

The XQ1271 is intended for use in ultra compact TV cameras for industrial and consumer applications.

QUICK REFERENCE DATA

Separate mesh	
Focusing	magnetic
Deflection	magnetic
Diameter	17,7 mm
Length	max. 108 mm
Heater	6,3 V, 95 mA
Limiting resolution	600 TV lines

OPTICAL

Diagonal of quality rectangle on photoconductive layer
(aspect ratio 3 : 4) 11 mm

Orientation of image on photoconductive layer:

The direction of the horizontal scan should be essentially parallel to the plane passing through pin 4 and the longitudinal axis of the tube.

Photoconductive layer type A

Spectral response, max. response at approx. 550 nm

Faceplate
thickness 1,5 mm
refractive index 1,487

HEATING

Indirect by a.c. or d.c.; parallel or series supply

Heater voltage V_f 6,3 V \pm 10%

Heater current at $V_f = 63$ V I_f 95 mA

When the tube is used in a series heater chain, the heater voltage must not exceed an r.m.s. value of 9,5 V when the supply is switched on.

CAPACITANCES

Signal electrode to all

$$C_{as} \approx 2 \text{ pF}$$

This capacitance, which is effectively the output impedance of the tube, increases when the tube is inserted into the deflection and focusing coil unit.

MECHANICAL DATA

Dimensions in mm

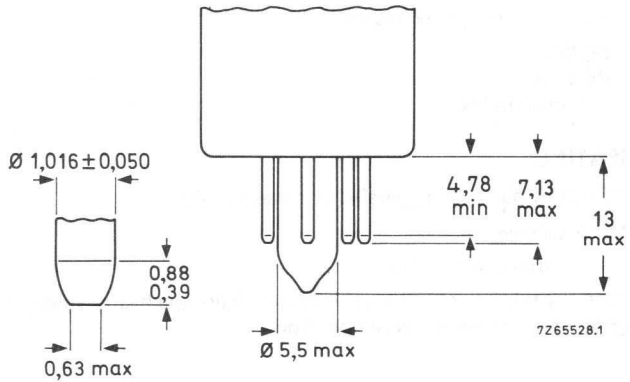
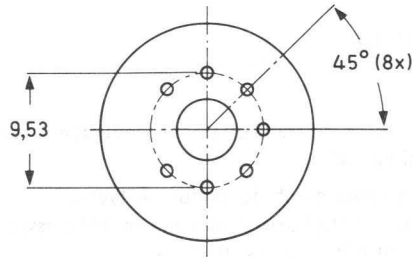
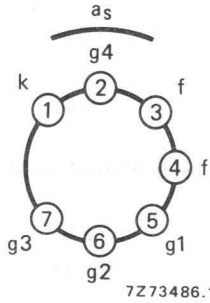
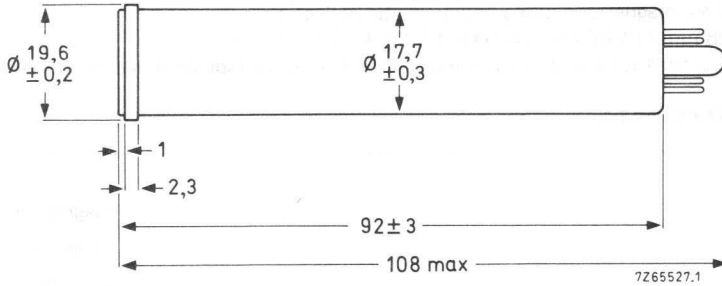

Base: JEDEC no. E7-91

Mounting position: any

Net mass: $\approx 23 \text{ g}$

ACCESSORIES

Socket	special miniature 7-pin, type 56049 or equivalent
Deflection and focusing coil unit	KV12S or equivalent

DEFLECTION magnetic

FOCUSING magnetic

LIMITING VALUES

(Absolute maximum rating system) for scanned area of 6,6 mm x 8,8 mm.

"Full-size scanning" i.e. scanning of a 6,6 mm x 8,8 mm area of the photoconductive layer should always be applied. Underscanning, i.e. scanning of an area smaller than 6,6 mm x 8,8 mm, may cause permanent damage to the specified full-size area.

Signal electrode voltage	V_{as}	max.	80 V
Grid 4 voltage	V_{g4}	max.	750 V
Grid 3 voltage	V_{g3}	max.	750 V
Grid 2 voltage	V_{g2}	max.	350 V
Grid 1 voltage, negative	$-V_{g1}$	max.	300 V
positive	V_{g1}	max.	0 V
Cathode-to-heater voltage, peak positive	V_{kfp}	max.	125 V
peak negative	$-V_{kfp}$	max.	10 V
Dark current, peak	I_{dp}	max.	150 nA
Output current, peak	I_{asp}	max.	500 nA*
Faceplate illumination	E	max.	10 000 lx
Faceplate temperature, storage and operation	T	max.	70 °C**
Cathode heating time before drawing cathode current	t_h	min.	1 min

* Video amplifiers should be capable of handling signal-electrode currents of this magnitude without overloading the amplifier or distorting the picture.

** Under difficult environmental conditions a flow of cooling air directed at the faceplate is recommended. When televising flames and furnaces, appropriate infrared absorbing filters should be used.

OPERATING CONDITIONS AND PERFORMANCE

For a scanned area of 6,6 mm x 8,8 mm and a faceplate temperature of 25 to 35 °C.

CONDITIONS

			notes
Grid 4 voltage	V_{g4}	400 V	1
Grid 3 (beam focus electrode) voltage	V_{g3}	300 V	1,2
Grid 2 (accelerator) voltage	V_{g2}	300 V	
Grid 1 voltage for picture cut-off (no blanking applied)	V_{g1}	-80 to -35 V	
Blanking voltage, peak-to-peak			
when applied to grid 1		75 V	
when applied to the cathode		20 V	
Flux density at centre of focusing coil		5,0 to 5,6 mT	
Flux density of adjustable alignment magnets		0 to 0,4 mT	

PERFORMANCE

		min.	typ.	max.	
Signal electrode voltage for dark current of 20 nA	V_{as}	10	30		V
Signal current faceplate illumination 10 lx c.t. 2856 K, dark current 20 nA	I_s	130	200		nA
Decay: residual signal current 60 ms after cessation of the illumination (c.t. 2856 K, initial signal current 200 nA, dark current 20 nA)			17		%
Limiting resolution at picture centre		550	600		TV lines 3
at picture corners		350	450		TV lines 3
Average γ of transfer characteristic for signal currents between 20 and 200 nA (see Fig. 1)		0,55	0,74	0,85	
Spurious signals (spots and blemishes)					4

Notes see next page.

NOTES

1. Grid 4 voltage must always be higher than grid 3 voltage. The recommended ratio of grid 4 voltage to grid 3 voltage both for best geometry and most uniform signal output depends upon the type of coil used and will be 4 : 3 for the recommended type (see "Accessories").
2. Resolution decreases with decreasing grid 3 voltage. In general grid 3 should be operated above 250 V.
3. On EIA resolution test chart; faceplate illumination adjusted for peak signal current of 200 nA and dark current of 20 nA.
4. Conditions:

The camera focused on a uniformly illuminated two-zone test pattern, the diameter of the centre zone (1) being equal to the raster height. Zone (2) being defined as the remainder of the scanned area. Signal electrode voltage adjusted for a dark current of 20 nA, illumination (c.t. 2856 K) adjusted to provide a signal current of 200 nA. Beam current adjusted for correct stabilization.

Scanning amplitudes of the monitor adjusted to obtain a raster aspect ratio of 3 : 4.

Monitor set-up and contrast control adjusted for faint raster when lens of camera is capped, and for non-blooming bright raster when lens of camera is uncapped.

Under the above conditions the number and size of the spots visible in the monitor picture will not exceed the limits stated below. Both black and white spots must be counted. Only white and black spots with contrasts $\geq 50\%$ and $\geq 100\%$ respectively (of peak white signal) are taken into account.

Spot size in % of raster height	Maximum number of spots	
	zone 1	zone 2
> 0,8	none	none
$\leq 0,8$ to 0,6	none	1
$\leq 0,6$ to 0,2	2	3
$\leq 0,2$	*	*
total (max.)	4	

- * Do not count spots of this size unless concentration causes a smudgy appearance.
- a) Minimum separation between any 2 spots greater than 0,4% of raster height is limited to a distance equivalent to 3% of raster height.
 - b) Tubes are rejected for smudge, lines, streaks, mottled, grainy or uneven background having contrasts $> 50\%$.

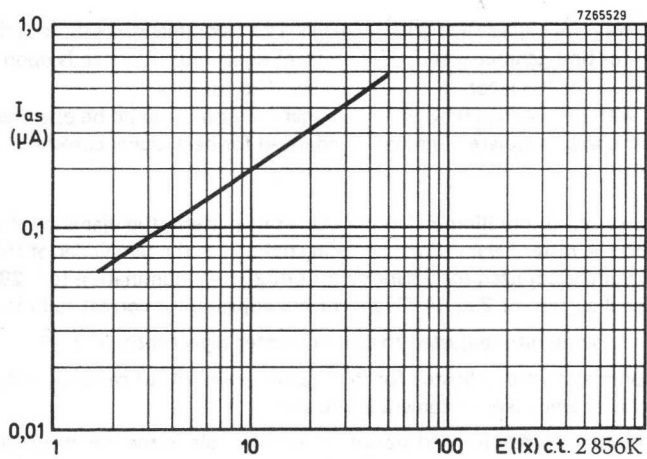

Fig. 1 Typical light transfer characteristic. Scanned area 6,6 mm x 8,8 mm. Faceplate temperature ≈ 30 °C.

CAMERA TUBE

Small size vidicon television camera tube with low heater consumption, separate mesh construction, electrostatic focusing and magnetic deflection. Overall length 108 mm (4 $\frac{1}{4}$ in) and diameter 17,7 mm (2/3 in).

The XQ1272 is intended for use in ultra compact TV cameras for industrial and consumer applications in which a minimum of size, weight and power consumption is essential.

QUICK REFERENCE DATA

Separate mesh	
Focusing	electrostatic
Deflection	magnetic
Diameter	17,7 mm
Length	max. 108 mm
Heater	6,3 V, 95 mA
Limiting resolution	550 TV lines

OPTICAL

Diagonal of quality rectangle on photoconductive layer
(aspect ratio 3 : 4) 11 mm

Orientation of image on photoconductive layer:

The direction of the horizontal scan should be essentially parallel to the plane passing through pin 4 and the longitudinal axis of the tube.

Photoconductive layer	type A
Spectral response, max. response at	approx. 550 nm
Faceplate thickness	1,5 mm
refractive index	1,487

HEATING

Indirect by a.c. or d.c.; parallel or series supply

Heater voltage	V_f	6,3 V \pm 10%
Heater current, at $V_f = 6,3$ V	I_f	95 mA

When the tube is used in a series heater chain, the heater voltage must not exceed an r.m.s. value of 9,5 V when the supply is switched on.

CAPACITANCES

Signal electrode to all

$$C_{as} \approx 2 \text{ pF}$$

This capacitance, which is effectively the output impedance of the tube, increases when the tube is inserted into the deflection coil unit.

MECHANICAL DATA

Dimensions in mm

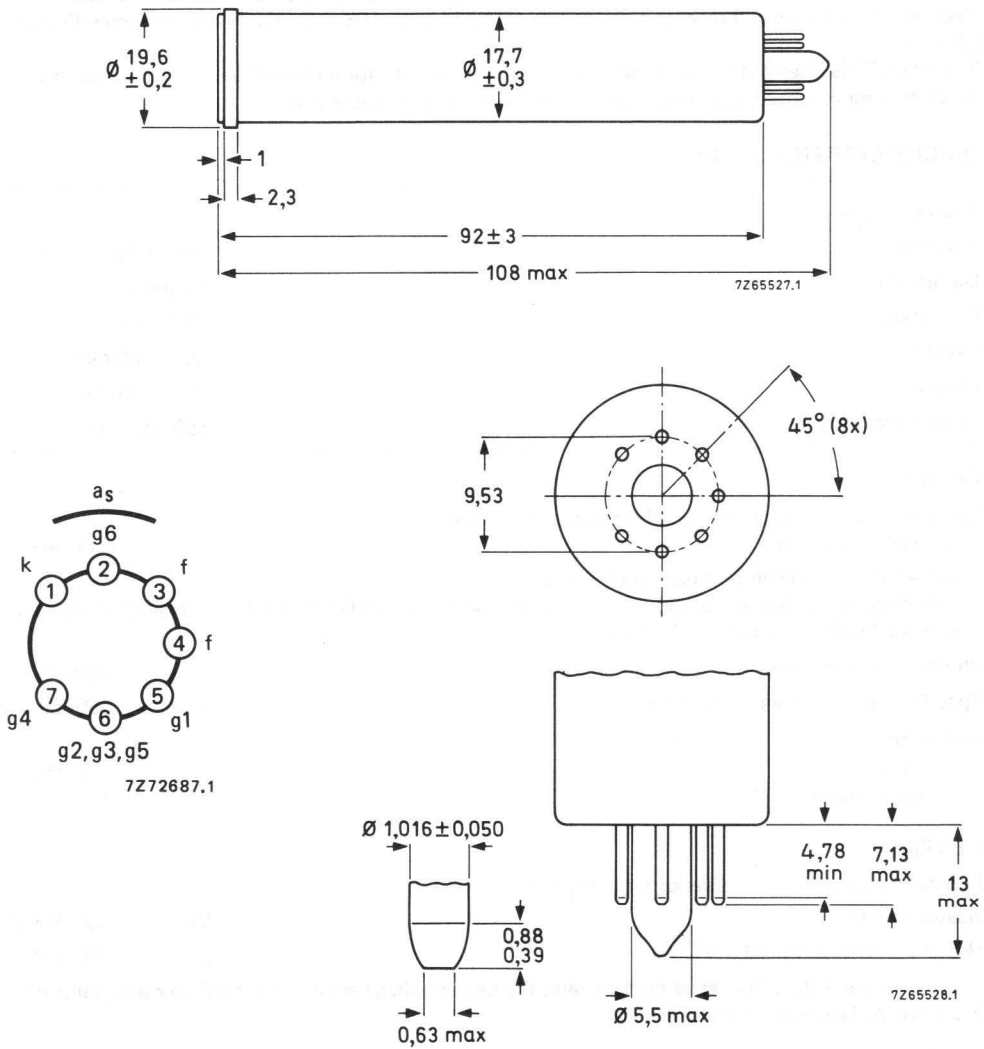

Base: JEDEC no. E7-91

Mounting position: any

Net mass: ≈ 25 g

ACCESSORIES

Socket	special miniature 7-pin, type 56049 or equivalent
Deflection coil unit	KV19G or equivalent

DEFLECTION magnetic

FOCUSING electrostatic

LIMITING VALUES

(Absolute maximum rating system) for scanned area of 6,6 mm x 8,8 mm.

"Full-size scanning" i.e. scanning of a 6,6 mm x 8,8 mm area of the photoconductive layer should always be applied. Underscanning, i.e. scanning of an area smaller than 6,6 mm x 8,8 mm, may cause permanent damage to the specified full-size area.

Signal electrode voltage	V_{as}	max.	80 V
Grid 6 voltage	V_{g6}	max.	600 V
Grid 4 (beam focus electrode) voltage	V_{g4}	max.	350 V
Grid 5, grid 3 and grid 2 voltage	$V_{g5,g3,g2}$	max.	350 V
Grid 1 voltage, negative	$-V_{g1}$	max.	300 V
positive	V_{g1}	max.	0 V
Cathode-to-heater voltage, peak positive	V_{kfp}	max.	125 V
peak negative	$-V_{kfp}$	max.	10 V
Dark current, peak	I_{dp}	max.	150 nA
Output current, peak	I_{asp}	max.	500 nA*
Faceplate illumination	E	max.	10 000 lx
Faceplate temperature, storage and operation	T	max.	70 °C **
Cathode heating time before drawing cathode current	t_h	min.	1 min

* Video amplifiers should be capable of handling signal-electrode currents of this magnitude without overloading the amplifier or distorting the picture.

** Under difficult environmental conditions a flow of cooling air directed at the faceplate is recommended. When televising flames and furnaces, appropriate infrared absorbing filters should be used.

OPERATING CONDITIONS AND PERFORMANCE

For a scanned area of 6,6 mm x 8,8 mm and a faceplate temperature of 25 to 35 °C.

CONDITIONS

			notes
Grid 6 (decelerator) voltage	V_{g6}	500 V	1
Grid 4 (beam focus electrode) voltage	V_{g4}	35 to 55 V	
Grid 5, grid 3 and grid 2 voltage	$V_{g5,g3,g2}$	300 V	1,2
Grid 1 voltage for picture cut-off (no blanking applied)	V_{g1}	-80 to -30 V	
Blanking voltage, peak-to-peak			
when applied to grid 1		75 V	
when applied to the cathode		20 V	
Flux density of adjustable alignment magnets		0 to 0,4 mT	

PERFORMANCE

		min.	typ.	max.	
Signal electrode voltage for dark current of 20 nA	V_{as}	10	30	V	
Signal current					
faceplate illumination 10 lx					
c.t. 2856 K, dark current 20 nA	I_s	130	200	nA	
Decay: residual signal current					
60 ms after cessation of the illumination					
(c.t. 2856 K, initial signal current 200 nA, dark current 20 nA)			17	%	
Limiting resolution at picture centre			600	TV lines	3
at picture corners			450	TV lines	
Average γ of transfer characteristic for signal currents between 20 and 200 nA (see Fig. 1)		0,55	0,74	0,85	
Spurious signals (spots and blemishes)					4

Notes see next page.

NOTES

1. Grid 6 voltage must always be higher than grid 5, 3 and 2 voltages. The recommended voltage ratio of grid 6 to grids 5, 3 and 2 both for best geometry and most uniform signal output current depends upon the type of coil used and will be 5 : 3 for the recommended type (see "Accessories").
2. Grid 5, 3 and 2 voltages must be operated above 250 V to provide sufficient beam current.
3. On EIA resolution test chart, faceplate illumination adjusted for peak signal current of 200 nA and dark current of 20 nA.
4. Conditions:

The camera focused on a uniformly illuminated two-zone test pattern, the diameter of the centre zone (1) being equal to the raster height. Zone (2) being defined as the remainder of the scanned area. Signal electrode voltage adjusted for a dark current of 20 nA, illumination (c.t. 2856 K) adjusted to provide a signal current of 200 nA. Beam current adjusted for correct stabilization.

Scanning amplitudes of the monitor adjusted to obtain a raster aspect ratio of 3 : 4.

Monitor set-up and contrast control adjusted for faint raster when lens of camera is capped, and for non-blooming bright raster when lens of camera is uncapped.

Under the above condions the number and size of the spots visible in the monitor picture will not exceed the limits stated below. Both black and white spots must be counted. Only white and black spots with contrasts $\geq 50\%$ and $\geq 100\%$ respectively (of peak white signal) are taken into account.

Spot size in % of raster height	Maximum number of spots	
	zone 1	zone 2
> 0,8	none	none
$\leq 0,8$ to 0,6	none	1
$\leq 0,6$ to 0,2	2	3
$\leq 0,2$	*	*
total (max.)	4	

* Do not count spots of this size unless concentration causes a smudgy appearance.

a) Minimum separation between any 2 spots greater than 0,4% of raster height is limited to a distance equivalent to 3% of raster height.

b) Tubes are rejected for smudge, lines, streaks, mottled, grainy or uneven background having contrasts $> 50\%$.

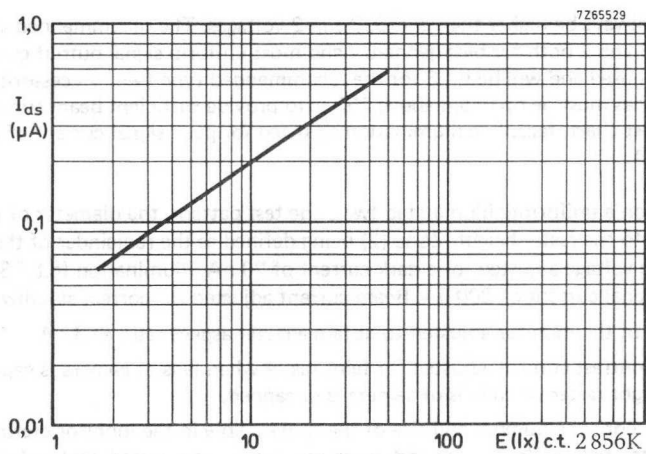

Fig. 1 Typical light transfer characteristic. Scanned area 6,6 mm x 8,8 mm. Faceplate temperature $\approx 30^{\circ}\text{C}$.

CAMERA TUBE

Vidicon TV camera tube with 25,4 mm (1 in) diameter, low heater power consumption, magnetic focusing and deflection, provided with a precision electron gun as in the 1 in diameter Plumbicon® tubes of the XQ1070 series.

The XQ1280 is intended mainly for use in medical or industrial X-ray equipment in which it is lens coupled to an X-ray image intensifier with a P11 or P20 output phosphor.

The tube is provided with a special photoconductive layer of high sensitivity in the 450 to 500 nm spectral region, and medium lag for proper X-ray noise integration.

QUICK REFERENCE DATA

Separate mesh	
Focusing	magnetic
Deflection	magnetic
Diameter	25,4 mm (1 in)
Length	159 mm (6¼ in)
Spectral response, max. at cut-off at	450 to 500 nm approx. 800 nm
Resolution	≥ 60 lp/mm
Heater	6,3 V, 95 mA

OPTICAL DATA

Dimensions of quality area on photoconductive target	circle of 16,2 mm dia (note 1)
Orientation of image on target	
The direction of the horizontal scan should be essentially parallel to the plane defined by pin 1 and the longitudinal axis of the tube.	
Photoconductive layer	type B
Spectral response, max at cut-off at	approx. 475 nm approx. 800 nm
Spectral response curve	see Fig. 1
Faceplate	
Refractive index	n 1,49
Thickness	2,3 ± 0,1 mm

MECHANICAL DATA

Dimensions in mm

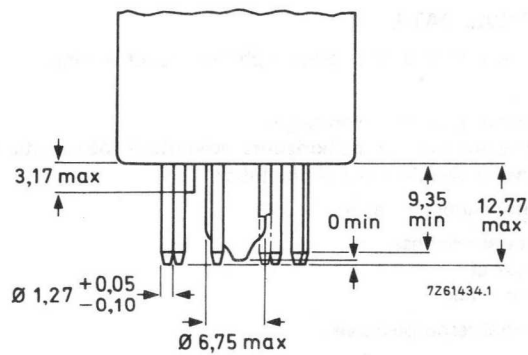
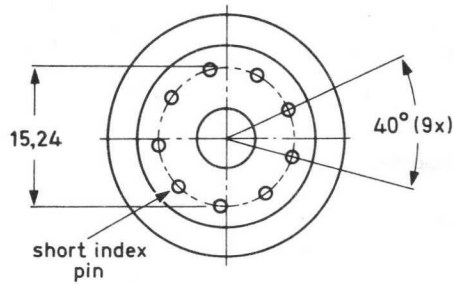
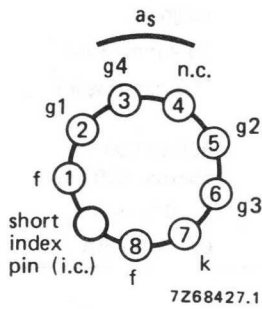
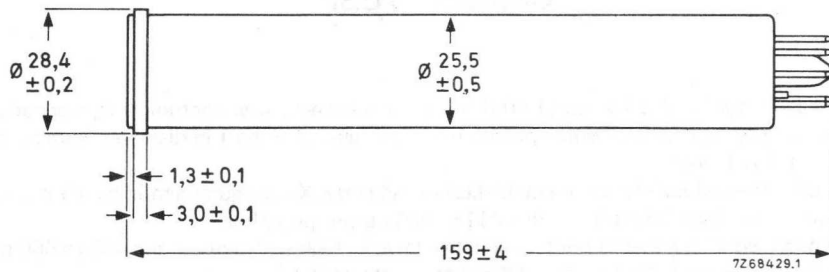

Base: IEC 67-I-33a (JEDEC E8-11)

Mounting position: any

Mass: ≈ 55 g

ACCESSORIES

Socket

Deflection and focusing coil

56098 or equivalent

AT1102/01, AT1116S or equivalent

ELECTRICAL DATA**Heating:** Indirect by a.c. or d.c.; parallel or series supply

Heater voltage	V_f	6,3 V \pm 10%
Heater current	I_f	95 mA

When the tube is used in a series heater chain, the heater voltage must never exceed an r.m.s. value of 9,5 V when the supply is switched on.

Electron gun characteristics

Cut-off grid 1 voltage for cut-off at $V_{g2} = 300$ V	V_{g1}	-30 to -100 V
Blanking voltage, peak-to-peak on grid 1	V_{g1pp}	50 ± 10 V
on cathode	V_{kpp}	20 V
Grid 2 current at normally required beam currents	I_{g2}	max. 0,5 mA

Focusing

magnetic

Deflection

magnetic

Capacitance

Signal electrode to all	C_{as}	3 to 5 pF
-------------------------	----------	-----------

This capacitance, which is effectively the output impedance, increases when the tube is inserted in the coil unit.

LIMITING VALUES

(Absolute maximum rating system)

All voltages are referred to the cathode, unless otherwise stated.

Signal electrode voltage	V_{as}	max.	100 V
Grid 4 voltage	V_{g4}	max.	1100 V
Grid 3 voltage	V_{g3}	max.	800 V
Voltage between grid 4 and grid 3	$V_{g4,g3}$	max.	450 V
Grid 2 voltage	V_{g2}	max.	350 V
Grid 1 voltage, negative	$-V_{g1}$	max.	125 V
positive	V_{g1}	max.	0 V

Cathode to heater voltage, peak positive	V_{kfp}	max.	125	V	notes
peak negative	$-V_{kfp}$	max.	50	V	
External resistance between cathode and heater at $-V_{kfp} > 10\text{ V}$	R_{kf}	min.	2	$k\Omega$	
Dark current, peak	I_{darkp}	max.	0,1	μA	
Output current, peak	I_{asp}	max.	0,6	μA	
The video amplifier should be capable of handling signal electrode currents of this magnitude without overloading.					
Faceplate illumination	E	max.	5000	lx	
Faceplate temperature, storage and operation	T	max.	80	$^{\circ}\text{C}$	

OPERATING CONDITIONS AND PERFORMANCE

For a target area of 15 mm diameter; faceplate temperature $30 \pm 2\text{ }^{\circ}\text{C}$.
All voltages are referred to the cathode, unless otherwise stated.

Typical operating conditions

		normal operation	operation for high resolution		
Grid 1 (control grid) voltage	V_{g1}	adjusted for sufficient beam current to stabilize a peak output current, I_{asp} , of 600 nA			
Grid 2 (accelerator) voltage	V_{g2}	300	300	V	
Grid 3 (collector) voltage	V_{g3}	375	600	V	2
Grid 4 (mesh) voltage	V_{g4}	600	960	V	2
Peak signal current	I_{sp}	150	150	nA	8, 9
Peak dark current	I_{darkp}	20	20	nA	
Blanking voltage, peak-to-peak when applied to grid 1 when applied to cathode	V_{g1pp}	50		V	
	V_{kpp}	20		V	
Field strength at centre of focusing coil (nominal)	H	3600	4800	A/m	3, 4
Field strength of adjustable alignment coils	H	0 to 320	0 to 320	A/m	5
Deflection currents					6

Performance

		min.	typ.	max.		notes
Signal electrode voltage for a peak dark current of 20 nA	V_{as}	30	40	70	V	
Grid 1 voltage for picture cut-off with no blanking applied	V_{g1}	-30	-55	-100	V	
Sensitivity						
Illumination required for a peak signal current of 150 nA						
P20	E		1 2×10^{-7}	2 4×10^{-7}	lx W/cm ²	
P11	E		0,2 $1,5 \times 10^{-7}$	0,4 3×10^{-7}	lx W/cm ²	
Decay:						
Residual signal current 200 ms after cessation of the illumination			15	20	%	10
Limiting resolution at picture centre,						
normal operation			≥ 50		lp/mm	11
operation for high resolution			≥ 60		lp/mm	11
Modulation transfer characteristic						
			see Fig. 4			
Average γ of transfer characteristic for						
signal currents between 10 nA and 200 nA			0,7			12
Spurious signals						
			see "Spurious signal specification for XQ1280"			

Notes see next page.

NOTES

1. a. The circular quality area of 16,2 mm diameter is concentric with the faceplate.
b. The scanning amplitudes must be so adjusted that a target area of about 15 mm diameter is displayed on a standard monitor as a circular area with a diameter equal to the raster height. (15 mm x 20 mm scan).
c. The displayed circular area of approximately 15 mm diameter should fall within the quality area of 16,2 mm diameter but is generally not concentric with the latter due to excentricities of the output window of the image intensifier and the optical system.
d. Underscanning of the chosen area, or failure of scanning, should be avoided, since this may cause damage to the photoconductive layer.
2. The optimal grid 4 voltage for best uniformity of black and white level depends on the type of coil unit used and will be 1,5 to 1,6 times V_{g3} for the coil units mentioned under "Accessories". Under no circumstances should grid 4 (mesh) be allowed to operate at a voltage level below that of grid 3, as this may damage the target.
3. Focus current adjusted for optimal electrical focus.
4. The polarity of the focusing coil should be such that its image end attracts an external north-seeking pole.
5. The alignment coil unit should be so positioned that its centre is at a distance of approx. 94 mm (3 11/16 in) from the face of the tube and that its axis coincides with the axis of the tube, the deflecting yoke and the focusing coil.
6. See chapter "Deflection units".
7. The dark current is dependent on the signal electrode voltage and the temperature. This is shown in Figs 2 and 3.
8. Signal current is output current minus dark current.
9. As measured on a waveform oscilloscope.
10. Measured with a 100% peak signal current of 150 nA.
11. Measured with a video amplifier system with suitable bandwidth and a high-quality lens adjusted to f: 5,6.
12. For typical transfer characteristics with P20 and P11 light input see Fig. 5 and 6.

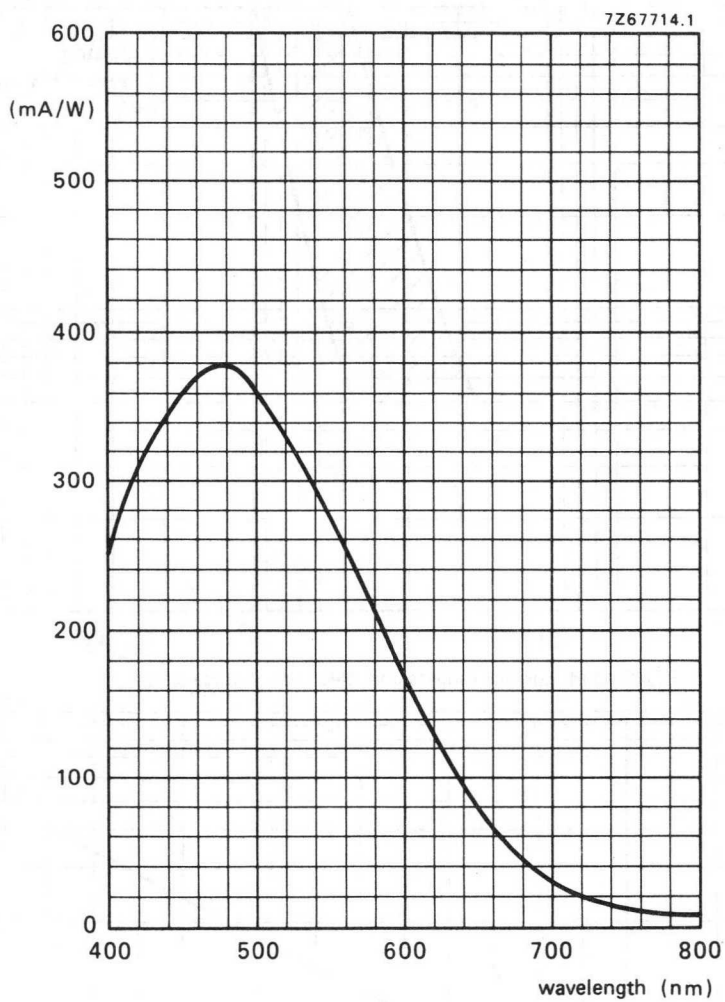

Fig. 1 Typical spectral response curve measured at constant output current $I_{as} = 50$ nA, with $I_{dark} = 20$ nA

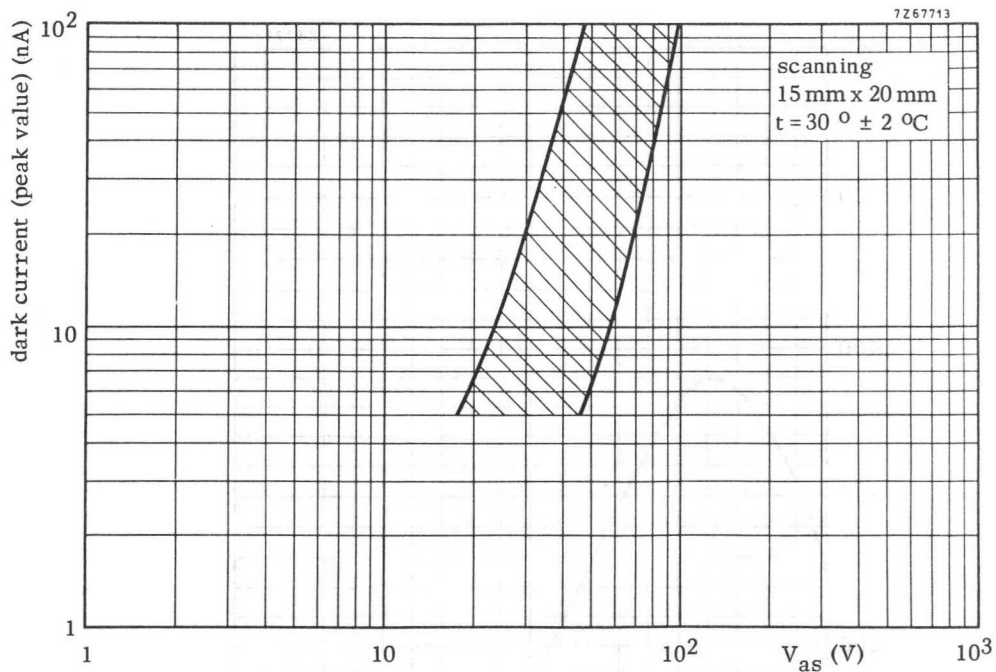

Fig. 2 Dark current range/signal electrode voltage curve.

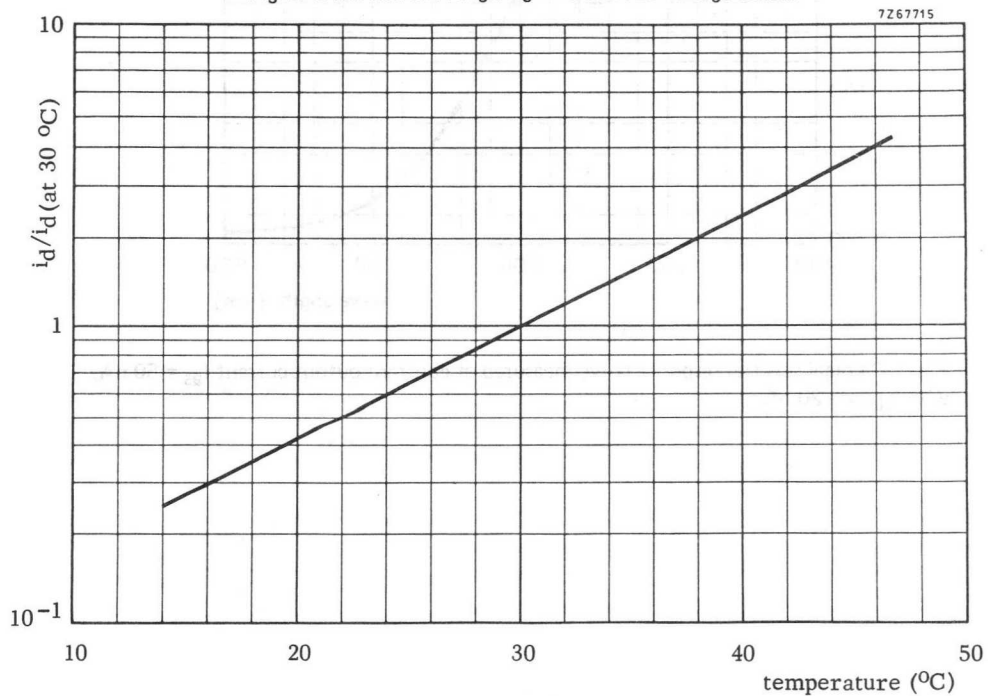

Fig. 3 Temperature dependence of dark current.

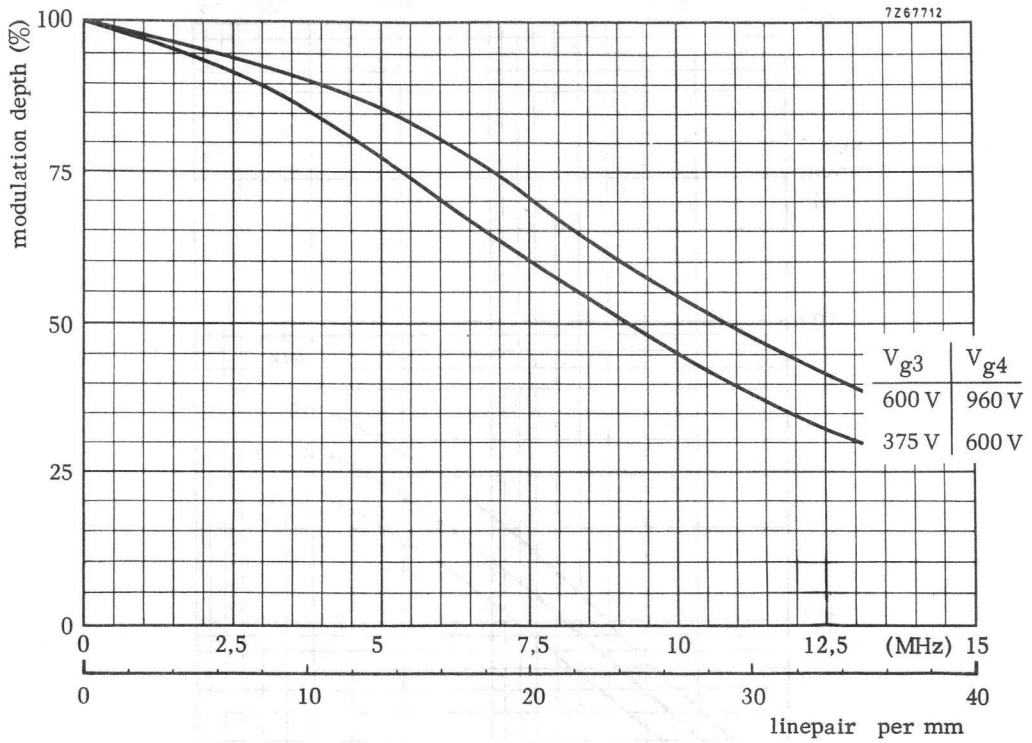

Fig. 4 Squarewave modulation transfer characteristic.

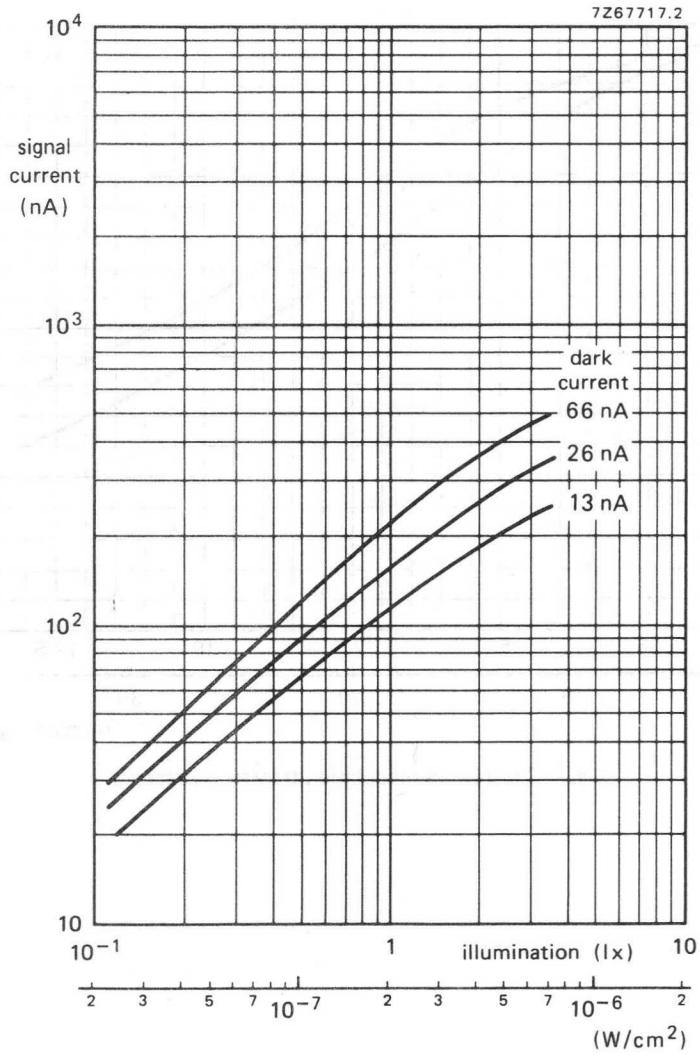

Fig. 5 Typical light transfer characteristic.
Scanning 15 mm x 20 mm; peak values;
P20 illumination.

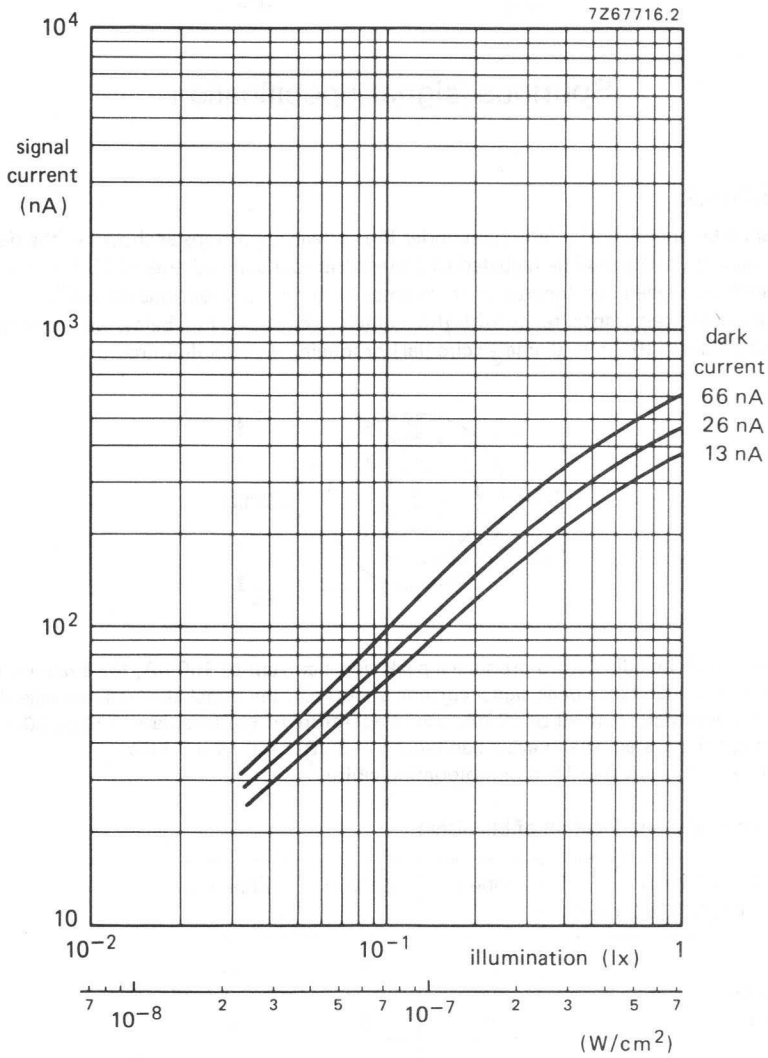
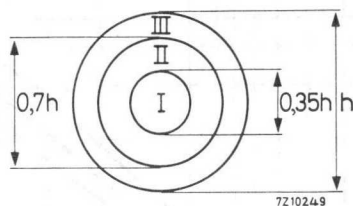

Fig. 6 Typical light transfer characteristic.
Scanning 15 mm x 20 mm; peak values;
P11 illumination.

Spurious signal specification

TEST CONDITIONS

- The tube shall be operated in a test chain under the voltage conditions as shown in the data sheet.
- The scanning amplitudes shall be adjusted to correspond to a scanned area of 16,2 mm x 21,6 mm.
- The tube shall be aligned and focused in accordance with the "Instructions for use".
- A back illuminated test transparency with three quality zones (see Fig. below) is projected onto the specified target area (16,2 mm diameter circular) producing an even illumination.



- The light level shall be adjusted to produce a peak signal current of 150 nA, the beam current shall be adjusted to just stabilize a peak signal current of 600 nA, the signal electrode voltage shall be adjusted for a peak dark current of 20 nA, the temperature of the faceplate shall be 30 ± 2 °C.
- The video amplifier system shall have a bandwidth (-3 dB) of at least 7 MHz.
- The monitor shall be adjusted for a non-blooming white.

Permitted number, size and location of blemishes

Dimensions of blemishes in % of picture height (16,2 mm)	Zone I	Zone II	Zone III
> 0,7	0	0	0
≤ 0,7 but > 0,45	0	1	3
≤ 0,45 but > 0,2	2	3	6
total	2	6	

Both black and white blemishes as observed on the monitor shall be counted. Blemishes $\leq 0,2\%$ of picture height* and blemishes with a contrast $\leq 6\%$ (of 150 nA peak signal current, as measured on a waveform oscilloscope), however, shall be neglected.

* Spots of this size are allowed unless concentration causes a smudgy appearance. The average contrast of the concentration is taken as the smudge contrast.

CAMERA TUBE

Vidicon TV camera tube with 25,4 mm (1 in) diameter, low heater power consumption, magnetic focusing and deflection, provided with a precision electron gun as in the 1 in diameter Plumbicon® tubes of the XQ1070 series.

The XQ1285 has a fibre optic faceplate and is mainly intended for use in medical or industrial X-ray equipment in which it is directly coupled to an X-ray image intensifier with a P11 or P20 phosphor on a fibre optic output window. For this purpose it is provided with a special photoconductive layer with a high sensitivity in the 450 to 500 nm spectral region and medium lag for proper X-ray noise integration.

QUICK REFERENCE DATA

Faceplate	fibre optic
Separate mesh	
Focusing	magnetic
Deflection	magnetic
Diameter	25,4 mm (1 in)
Length	159 mm (6¼ in)
Heater	6,3 V, 95 mA
Spectral response, max. at cut-off at approx.	450 to 500 nm 800 nm
Resolution	≥ 50 lp/mm

OPTICAL DATA

Dimensions of quality area on photoconductive target	circle of 15,8 mm dia (note 1)
Orientation of image on target The direction of the horizontal scan should be essentially parallel to the plane defined by pin 1 and the longitudinal axis of the tube.	
Photoconductive layer	type B
Spectral response, max. at cut-off	approx. 475 nm approx. 800 nm
Spectral response curve	see Fig. 1
Faceplate	
Centre to centre spacing of fibres	7,5 µm
Flat within	1,5 µm
Numerical aperture	1,0

MECHANICAL DATA

Dimensions in mm

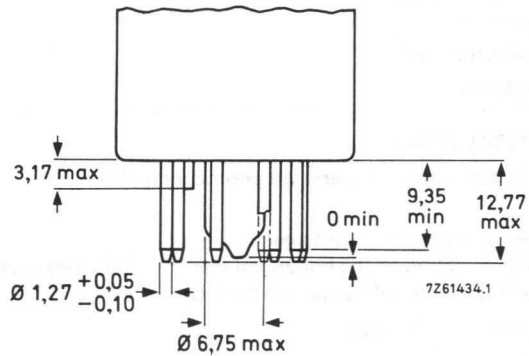
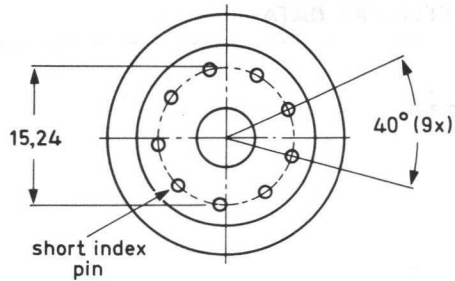
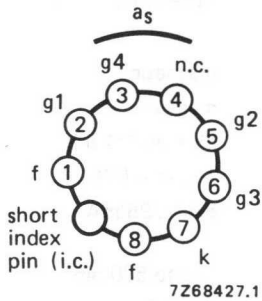
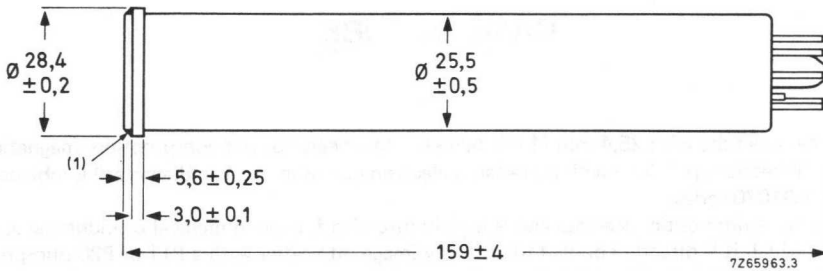

Base: JEDEC E8-11; IEC 67-I-33a

Mounting position: any

Weight: ≈ 55 g

ACCESSORIES

Socket

56098 or equivalent

Deflection and focusing coil unit

AT1102/01, AT1116S or equivalent

- (1) Epoxy resin. Proper coupling of the XQ1285 to the fibre optic output window of an image intensifier may be obtained by mechanical arrangements which either exert an evenly distributed axial forward pulling force on the signal-electrode ring or an axial forward pushing force on the base end or socket of the tube.
In either case the recommended force is in the order of 100 to 120 N.

ELECTRICAL DATA**Heating:** Indirect by a.c. or d.c.; parallel or series supply

Heater voltage	V_f	$6,3 \text{ V} \pm 10\%$
Heater current, at $V_f = 6,3 \text{ V}$	I_f	95 mA

When the tube is used in a series heater chain, the heater voltage must never exceed an r.m.s. value of 9,5 V when the supply is switched on.

Electron gun characteristics

Cut-off

grid 1 voltage for cut-off at $V_{g2} = 300 \text{ V}$	V_{g1}	-30 to -100 V
--	----------	---------------

Blanking voltage, peak-to-peak

on grid 1	V_{g1pp}	$50 \pm 10 \text{ V}$
on cathode	V_{kpp}	20 V

Grid 2 current at normally required beam currents	I_{g2}	max. 0,5 mA
---	----------	-------------

Focusing

magnetic

Deflection

magnetic

Capacitance

Signal electrode to all	C_{as}	3 to 5 pF
-------------------------	----------	-----------

This capacitance, which effectively is the output impedance of the tube, increases when the tube is inserted into the deflection and focusing coil unit.

LIMITING VALUES

(Absolute maximum rating system)

All voltages are referred to the cathode, unless otherwise stated.

Signal electrode voltage	V_{as}	max.	100 V
Grid 4 voltage	V_{g4}	max.	1100 V
Grid 3 voltage	V_{g3}	max.	800 V
Voltage between grid 4 and grid 3	$V_{g4,g3}$	max.	450 V
Grid 2 voltage	V_{g2}	max.	350 V
Grid 1 voltage, negative	$-V_{g1}$	max.	125 V
positive	V_{g1}	max.	0 V
Cathode-to-heater voltage, peak positive	V_{kfp}	max.	125 V
peak negative	$-V_{kfp}$	max.	50 V
External resistance between cathode and heater at $-V_{kfp} > 10 \text{ V}$	R_{kf}	min.	2 k Ω

Dark current, peak	I_{darkp}	max.	0,1	μA	notes
Output current, peak	I_{asp}	max.	0,6	μA	
Axial force on signal-electrode ring in forward direction (evenly distributed)		max.	200	N	
Faceplate illumination	E	max.	5000	lx	
Faceplate temperature, storage and operation	T	max.	80	$^{\circ}\text{C}$	
		min.	-30	$^{\circ}\text{C}$	

OPERATING CONDITIONS AND PERFORMANCE

For a target area of 15 mm diameter; faceplate temperature 30 ± 2 $^{\circ}\text{C}$.
All voltages are referred to the cathode, unless otherwise stated.

Typical operating conditions

		normal operation	operation for high resolution		
Grid 1 (control grid) voltage	V_{g1}	adjusted for sufficient beam current to stabilize a peak output current, I_{asp} , of 600 nA			
Grid 2 (accelerator) voltage	V_{g2}	300	300	V	
Grid 3 (collector) voltage	V_{g3}	375	600	V	
Grid 4 (mesh) voltage	V_{g4}	600	960	V	2
Peak signal current	I_{sp}	150	150	nA	8
Peak dark current	I_{darkp}	20	20	nA	
Blanking voltage, peak-to-peak when applied to grid 1	$V_{g1\text{pp}}$	50		V	
when applied to cathode	$V_{k\text{pp}}$	50		V	
Field strength at centre of focusing coil (nominal)	H	3200	4800	A/m	3, 4
Field strength of adjustable alignment coils	H	0 to 320	0 to 320	A/m	6
Deflection currents					6

Performance

		min.	typ.	max.		notes
Signal electrode voltage for a peak dark current of 20 nA	V_{as}	30	40	75	V	7, 9
Grid 1 voltage for picture cut-off, with no blanking applied	V_{g1}	-30	-55	-100	V	
Sensitivity						
Illumination required for a peak signal current of 150 nA						
P20	E		1,5 3×10^{-7}	3 6×10^{-7}	lx W/cm ²	
P11	E		0,3 $2,3 \times 10^{-7}$	0,6 $4,5 \times 10^{-7}$	lx W/cm ²	
Decay:						
Residual signal current 200 ms after cessation of the illumination			15	20	%	10
Limiting resolution at picture centre,						
normal operation			≥ 50		lp/mm	11
operation for high resolution			≥ 60		lp/mm	11
Modulation transfer characteristic						
			see Fig. 4			
Average γ of transfer characteristic for						
signal currents between 10 nA and 300 nA			0,7			12
Spurious signals						
			see "Spurious signal specification for XQ1285"			

Notes see next page.

NOTES

1. a. The circular quality area of 15,8 mm diameter is concentric with the faceplate.
b. The scanning amplitudes are so adjusted that a target area of about 15 mm diameter is displayed on a standard monitor as a circular area with a diameter equal to the raster height. (15 mm x 20 mm scan).
c. The displayed circular area of approximately 15 mm diameter should fall within the quality area of 15,8 mm diameter but is generally not concentric with the latter due to eccentricities of the output window of the image intensifier and of the optical system.
d. Underscanning of the chosen target area, or failure of scanning, should be avoided, so as not to cause damage to the photoconductive layer.
2. The optimal grid 4 voltage for best uniformity of black and white level depends on the type of coil unit used and will be 1,5 to 1,6 times V_{g3} for the coil units mentioned under "Accessories". Under no circumstances should grid 4 (mesh) be allowed to operate at a voltage level below that of grid 3, as this may damage the target.
3. Focus current adjusted for optimal electrical focus.
4. The polarity of the focusing coil should be such that its image end attracts an external north-seeking pole.
5. The alignment coil unit should be so positioned that its centre is at a distance of approx. 94 mm (3 11/16 in) from the face of the tube and that its axis coincides with the axis of the tube, the deflecting yoke and the focusing coil.
6. See chapter "Deflection units".
7. The dark current is dependent on the signal electrode voltage and the temperature. This is shown in Figs 2 and 3.
8. Signal current is output current minus dark current.
9. As measured on a waveform oscilloscope.
10. Measured with a 100% peak signal current of 150 nA.
11. Obtained with a video amplifier system with adequate bandwidth.

Measured with a transparent square-wave test pattern applied directly to the faceplate and which is illuminated with P20 light of a lambertian distribution. The average transmission of the test transparency is about 50% of the transmission of the transparency's whites.

No aperture correction or gamma correction is applied.

12. For typical transfer characteristics with P20 and P11 light input see Figs 5 and 6.

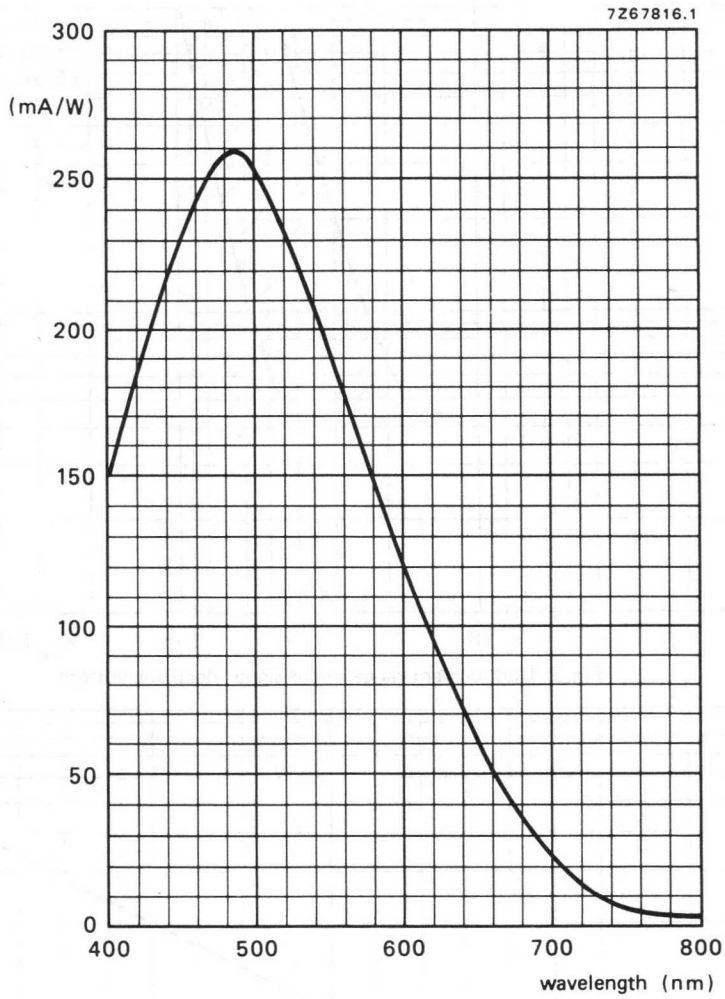

Fig. 1 Spectral response curve.

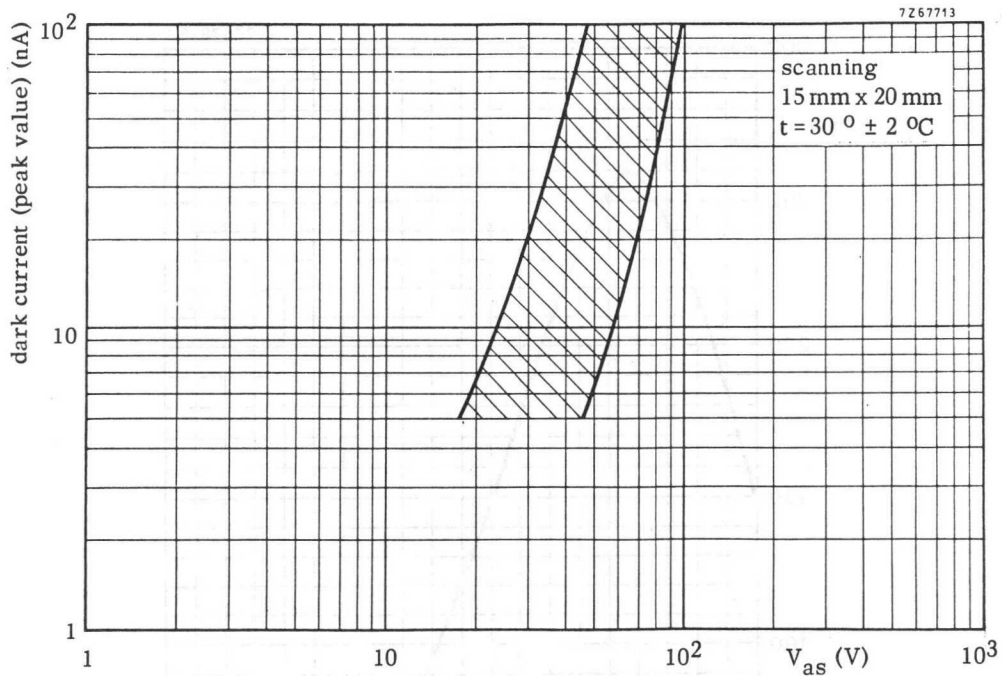

Fig. 2 Dark current range versus signal electrode voltage.

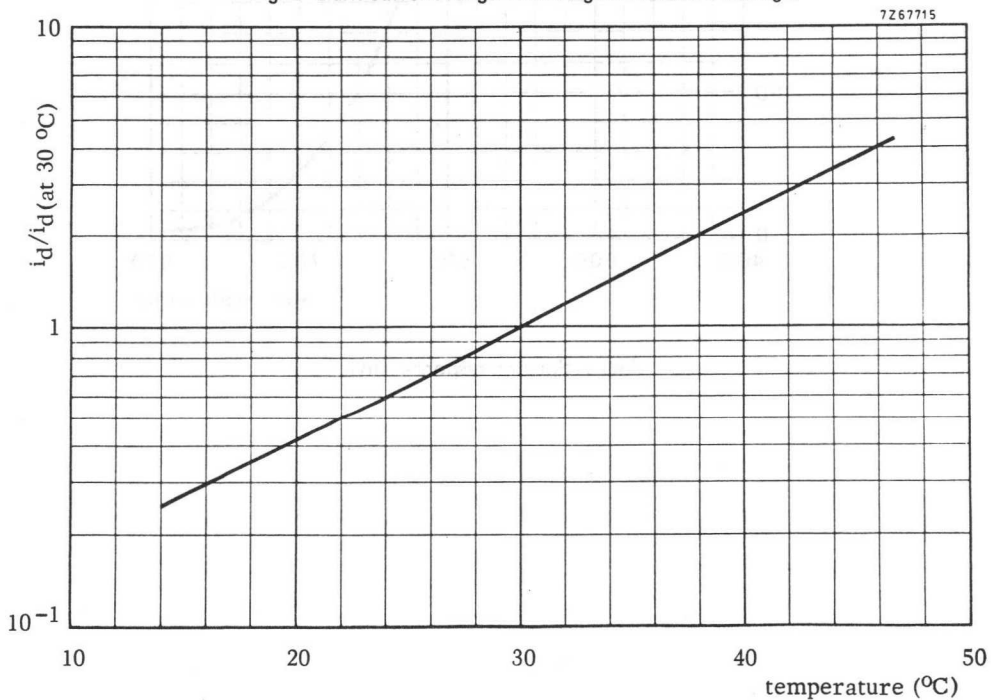

Fig. 3 Temperature dependence of dark current.

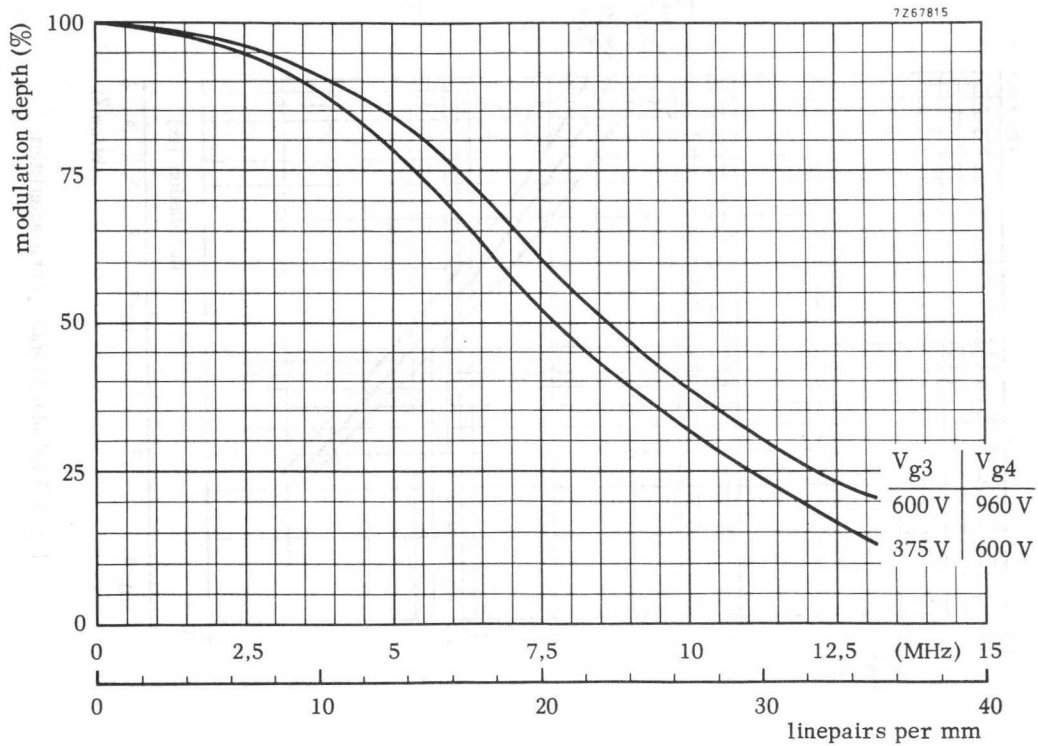

Fig. 4 Square wave modulation transfer characteristic.

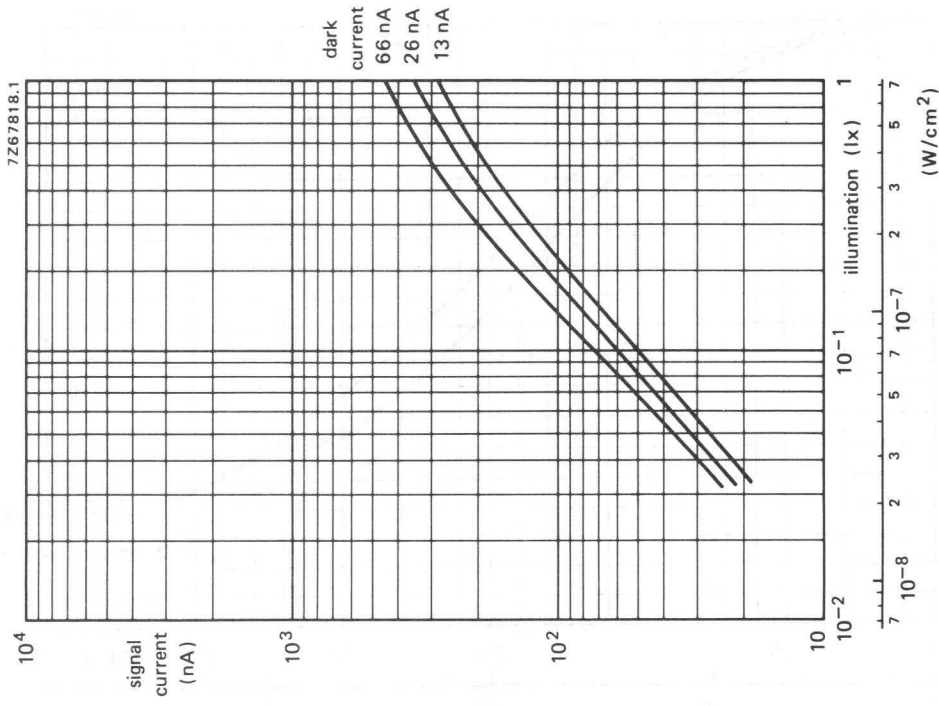

Fig. 6 Typical light transfer characteristics.

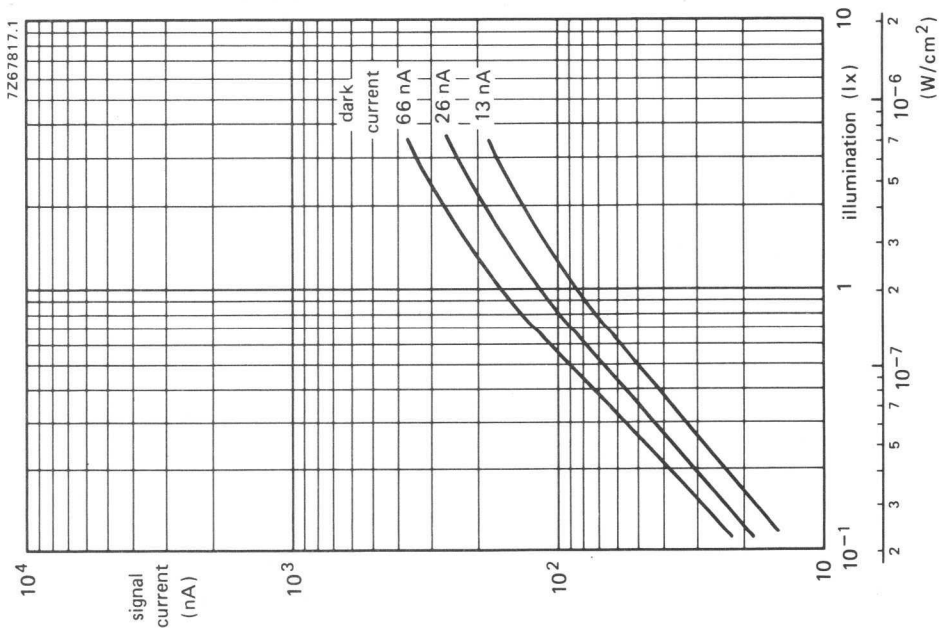
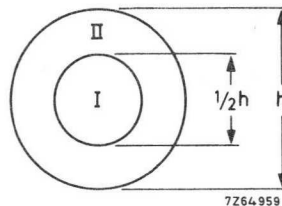

Fig. 5 Typical light transfer characteristics.

Spurious signal specification

TEST CONDITIONS

- The tube shall be operated in a test chain under the voltage conditions as shown in the data sheet.
- The scanning amplitudes shall be adjusted to overscan the target such that it is displayed as a circle on the monitor.
- A test transparency, back illuminated with lambertian light of c.t. = 2856 K, with two quality zones (see Fig. below) is applied directly to the faceplate and positioned such that it is concentric with the target as observed on the monitor.
- The tube shall be aligned and focused.
- The scanning amplitudes shall be slightly reduced, horizontal and vertical centring controls be adjusted such that the circular area of 15,8 mm dia just fits in the picture height of the monitor and is displayed as a circle.
- The temperature of the faceplate shall be 30 ± 2 °C.
The signal electrode voltage shall be adjusted for a peak dark current of 20 nA.
The light level shall be adjusted to produce a peak signal current of 150 nA, the beam current shall be adjusted to just stabilize a peak signal current of 600 nA.
- The video amplifier shall have a bandwidth (-3 dB) of at least 7 MHz.
- The monitor shall be adjusted for a non-blooming white.



$h = 15,8$ mm on target
 $1/2h = 7,9$ mm on target

Permitted number, size and location of blemishes

The table below shows what number of blemishes, black or white, are permitted per size, per zone and total (notes 1 and 2).

Dimensions of blemishes in % of picture height	Zone I		Zone II		Total I + II
	white	black	white	black	
> 0,8	0	0	0	0	0
≤ 0,8 but > 0,5	0	1	0	2	2
≤ 0,5 but > 0,4	1	2	2	3	4
≤ 0,4 but > 0,2	2	3	4	5	6
≤ 0,2 (note 3)					
total	3		6		8

Background structure (e.g. chicken wire pattern) originating from the fibre-optic faceplate shall not have a contrast exceeding 2%. (note 2)

NOTES

- Both black and white blemishes as observed on the monitor shall be counted, however, blemishes ≤ 0,2% of picture height and black blemishes with a contrast ≤ 6%, and white blemishes with a contrast ≤ 3% shall be ignored.
- The contrast is measured as a percentage of 150 nA peak signal current on a waveform oscilloscope. The dimensions of blemishes are determined on the monitor with a transparent blemish gauge, calibrated in percent of picture height.
- If such blemishes form a concentration this will be evaluated as a blemish with as contrast the average contrast of the concentration.

CAMERA TUBE

Small size vidicon television camera tube with low heater consumption, separate mesh construction, electrostatic focusing and magnetic deflection and mechanically interchangeable with vidicons such as XQ1272. Overall length 108 mm (4 1/4 in) and diameter 17,7 mm (2/3 in).

The XQ1590 is intended for use in ultra compact TV cameras for industrial and consumer applications in which a minimum of size, weight and power consumption is essential.

QUICK REFERENCE DATA

Separate mesh	
Focusing (bipotential focusing lens)	electrostatic
Deflection	magnetic
Diameter	17,7 mm
Length	max. 108 mm
Heater	6,3 V, 95 mA
Limiting resolution	550 TV lines

OPTICAL

Diagonal of quality rectangle on photoconductive layer
(aspect ratio 3 : 4) 11 mm

Orientation of image on photoconductive layer:

The direction of the horizontal scan should be essentially parallel to the plane passing through pin 4 and the longitudinal axis of the tube.

Photoconductive layer		type A
Special response, max. response at	approx.	550 nm
Faceplate thickness		1,5 mm
refractive index		1,487

HEATING

Indirect by a.c. or d.c. parallel or series supply

Heater voltage	V_f	6,3 V \pm 10%
Heater current, at $V_f = 6,3$ V	I_f	95 mA

When the tube is used in a series heater chain, the heater voltage must not exceed an r.m.s. value of 9,5 V when the supply is switched on.

CAPACITANCES

Signal electrode to all

$$C_{as} \approx 2 \text{ pF}$$

This capacitance, which is effectively the output impedance of the tube, increases when the tube is inserted into the deflection coil unit.

MECHANICAL DATA

Dimensions in mm

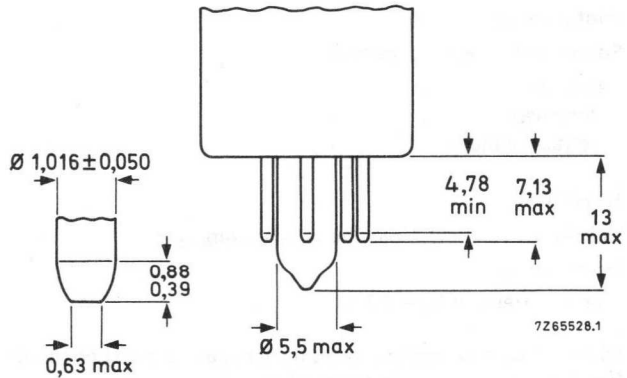
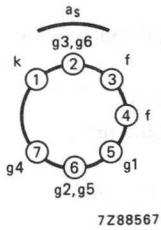
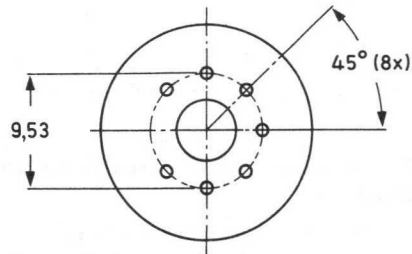
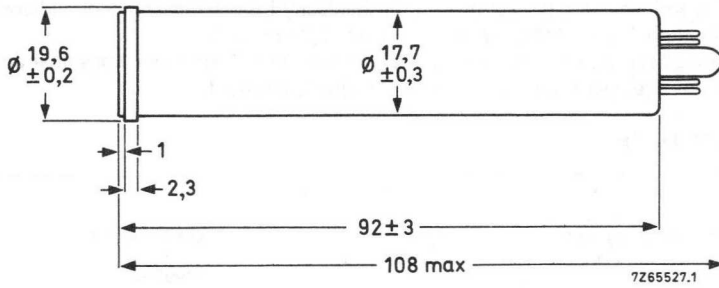

Base: JEDEC no. E7-91

Mounting position: any

Net mass: ≈ 25 g

ACCESSORIES

Socket	special miniature 7-pin, type 56049 or equivalent
Deflection coil unit	KV19G or equivalent

DEFLECTION

magnetic

FOCUSING

electrostatic

LIMITING VALUES

(Absolute maximum rating system) for scanned area of 6,6 mm x 8,8 mm.

"Full-size scanning" i.e. scanning of a 6,6 mm x 8,8 mm area of the photoconductive layer should always be applied. Underscanning, i.e. scanning of an area smaller than 6,6 mm x 8,8 mm, may cause permanent damage to the specified full-size area.

Signal electrode voltage	V_{as}	max.	80 V
Grid 3 and 6 voltage	$V_{g3,g6}$	max.	750 V
Grid 4 (beam focus electrode) voltage	V_{g4}	max.	350 V
Grid 2 and 5 voltage	$V_{g2,g5}$	max.	350 V
Grid 1 voltage, negative	$-V_{g1}$	max.	300 V
positive	V_{g1}	max.	0 V
Cathode-to-heater voltage peak positive	V_{kfp}	max.	125 V
peak negative	$-V_{kfp}$	max.	10 V
Dark current, peak	I_{dp}	max.	150 nA
Output current, peak	I_{asp}	max.	500 nA*
Faceplate illumination	E	max.	10 000 lx
Faceplate temperature, storage and operation	T	max.	70 °C**
Cathode heating time before drawing cathode current	t_h	min.	1 min

* Video amplifiers should be capable of handling signal-electrode currents of this magnitude without overloading the amplifier or distorting the picture.

** Under difficult environmental conditions a flow of cooling air directed at the faceplate is recommended. When televising flames and furnaces, appropriate infrared absorbing filters should be used.

OPERATING CONDITIONS AND PERFORMANCE

For a scanned area of 6,6 mm x 8,8 mm and a faceplate temperature of 25 to 35 °C.

CONDITIONS

			notes
Grid 3 and 6 (decelerator) voltage	$V_{g3,g6}$	500 V	1
Grid 4 (beam focus electrode) voltage	V_{g4}	60 to 85 V	2
Grid 2 and 5 voltage	$V_{g2,g5}$	300 V	3
Grid 1 voltage for picture cut-off (no blanking applied)	V_{g1}	-80 to -30 V	
Blanking voltage, peak-to-peak when applied to grid 1		75 V	
when applied to the cathode		20 V	
Flux density of adjustable alignment magnets		0 to 0,4 mT	

PERFORMANCE

	min.	typ.	max.	
Signal electrode voltage for dark current of 20 nA	V_{as} 15	30	V	
Signal current faceplate illumination 10 lx c.t. 2856 K, dark current 20 nA	I_s 130	200	nA	
Decay: residual signal current 60 ms after cessation of the illumination (c.t. 2858 K, initial signal current 200 nA, dark current 20 nA)		17	%	
Limiting resolution at picture centre		550	TV lines 4	
at picture corners		475	TV lines 4	
Average γ of transfer characteristic for signal currents between 20 and 200 nA (see Fig. 1)	0,55	0,74	0,85	
Spurious signals (spots and blemishes)				5

Notes see next page.

Notes

1. Grids 3 and 6 voltage must always be higher than grids 2 and 5 voltage. The recommended voltage ratio of grids 3 and 6 to grids 2 and 5 both for best geometry and most uniform signal output current depends upon the type of coil used and will be 5 : 3 for the recommended type (see "Accessories").
2. Adjusted for correct electrical focus. This voltage range is higher than that of unipotential electrostatic focus types, such as XQ1272.
3. Grids 2 and 5 voltage must be > 250 V to provide sufficient beam current.
4. On EIA resolution test chart, faceplate illumination adjusted for peak signal current of 200 nA and dark current of 20 nA.

5. Conditions:

The camera focused on a uniformly illuminated two-zone test pattern, the diameter of the centre zone (1) being equal to the raster height. Zone (2) being defined as the remained of the scanned area. Signal electrode voltage adjusted for a dark current of 20 nA, illumination (c.t. 2856K) adjusted to provide a signal current of 200 nA. Beam current adjusted for correct stabilization.

Scanning amplitudes of the monitor adjusted to obtain a raster aspect ratio of 3 : 4.

Monitor set-up and contrast control adjusted for faint raster when lens of camera is capped, and for non-blooming bright raster when lens of camera is uncapped.

Under the above conditions the number and size of the spots visible in the monitor picture will not exceed the limits stated below. Both black and white spots must be counted. Only white and black spots with contrasts $\geq 50\%$ and $\geq 100\%$ respectively (of peak white signal) are taken into account.

Spot size in % of raster height	Maximum number of spots	
	zone 1	zone 2
$> 0,8$	none	none
$\leq 0,8$ to 0,6	none	1
$\leq 0,6$ to 0,2	2	3
$\leq 0,2$	*	*
total (max.)	4	

* Do not count spots of this size unless concentration causes a smudgy appearance.

- a) Minimum separation between any 2 spots greater than 0,4% of raster height a limited to a distance equivalent to 3% of raster height.
- b) Tubes are rejected for smudge, lines, streaks, mottled, grainy or uneven background having contrasts $> 50\%$.

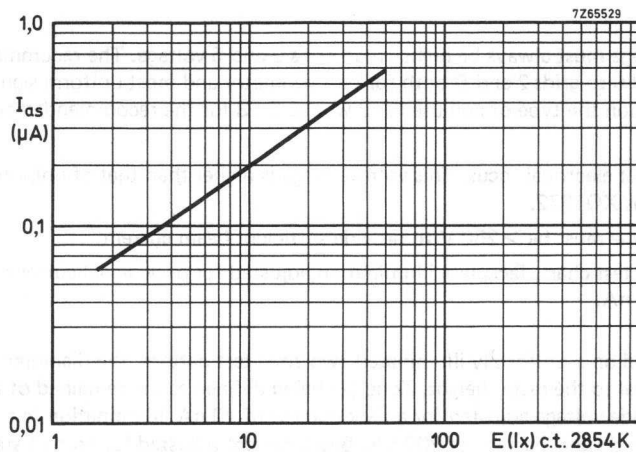

Fig. 1. Typical light transfer characteristic. Scanned area 6,6 mm x 8,8 mm.
Faceplate temperature ≈ 30 °C.

CAMERA TUBE

Extremely small size vidicon television camera tube with very low heater consumption, separate mesh construction, electrostatic focusing and magnetic deflection. Overall length 85 mm (3½ in) and diameter 13,5 mm (½ in).

The XQ1600 is intended for use in ultra-compact TV cameras for industrial and consumer applications in which a minimum of size, weight and power consumption is essential.

QUICK REFERENCE DATA

Separate mesh	
Focusing	electrostatic
Deflection	magnetic
Diameter	13,5 mm
Length	max. 85 mm
Heater	2,8 V, 107 mA
Limiting resolution	450 TV lines

OPTICAL

Diagonal of quality rectangle on photoconductive layer
(aspect ratio 3 : 4) 7,75 mm

Orientation of image on photoconductive layer:

The direction of the horizontal scan should be essentially parallel to the plane passing through the short index pin and the longitudinal axis of the tube.

Photoconductive layer	type A
Spectral response, max. response at	approx. 550 nm
Faceplate thickness	1,6 mm
refractive index	1,474

HEATING

Indirect by a.c. or d.c. parallel or series supply

Heater voltage	V_f 2,8 V \pm 5%
Heater current, at $V_f = 2,8$ V	I_f 107 mA \pm 10%

When the tube is used in a series heater chain, the heater voltage must not exceed an r.m.s. value of 3,5 V when the supply is switched on.

CAPACITANCES

Signal electrode to all

$$C_{as} \approx 1,5 \text{ pF}$$

This capacitance, which is effectively the output impedance of the tube, increases when the tube is inserted into the deflection coil unit.

MECHANICAL DATA

Dimensions in mm

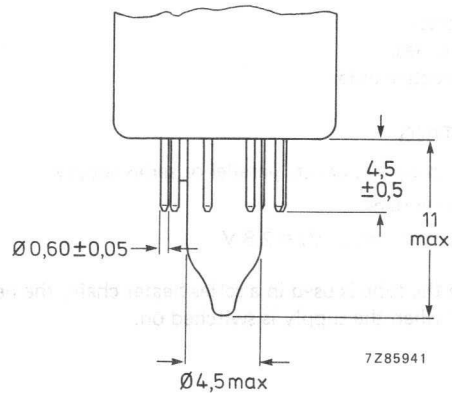
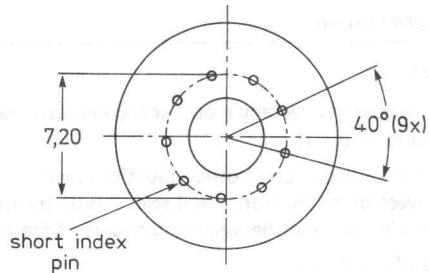
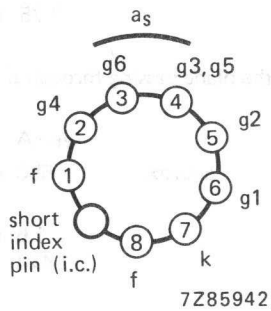
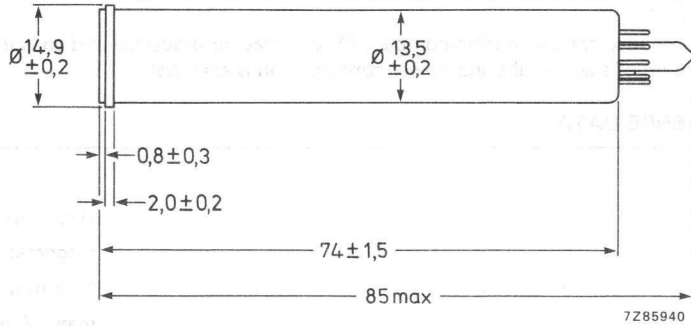

Mounting position: any

Net mass: $\approx 12 \text{ g}$

ACCESSORIES

Socket	special miniature 8-pin type 56600 or equivalent
Deflection coil unit	KV29E or equivalent

DEFLECTION

magnetic

FOCUSING

electrostatic

LIMITING VALUES

(Absolute maximum rating system) for scanned area of 4,65 mm x 6,2 mm.

"Full-size scanning" i.e. scanning of a 4,65 mm x 6,2 mm area of the photoconductive layer should always be applied. Underscanning, i.e. scanning of an area smaller than 4,65 mm x 6,2 mm, may cause permanent damage to the specified full-size area.

Signal electrode voltage	V_{as}	max.	70 V
Grid 6 voltage	V_{g6}	max.	600 V
Grid 4 (beam focus electrode) voltage	V_{g4}	max.	350 V
Grid 3 and 5 voltage	$V_{g3,5}$	max.	450 V
Grid 2 voltage	V_{g2}	max.	400 V
Grid 1 voltage, negative	$-V_{g1}$	max.	300 V
positive	V_{g1}	max.	0 V
Cathode-to-heater voltage peak positive	V_{kfp}	max.	125 V
peak negative	$-V_{kfp}$	max.	10 V
Dark current, peak	I_{dp}	max.	80 nA
Output current, peak	I_{asp}	max.	500 nA*
Faceplate illumination	E	max.	10 000 lx
Faceplate temperature, storage and operation	T	max.	70 °C**
Cathode heating time before drawing cathode current	t_h	min.	1 min

* Video amplifiers should be capable of handling signal-electrode currents of this magnitude without overloading the amplifier or distorting the picture.

** Under difficult environmental conditions a flow of cooling air directed at the faceplate is recommended. When televising flames and furnaces, appropriate infrared absorbing filters should be used.

OPERATING CONDITIONS AND PERFORMANCE

For a scanned area of 4,65 mm x 6,2 mm and a faceplate temperature of 25 to 35 °C and standard TV scanning rate.

CONDITIONS

			notes
Grid 6 (decelerator) voltage	V_{g6}	500 V	1
Grid 4 (beam focus electrode) voltage	V_{g4}	31 to 55 V	
Grid 3 and 5 voltage	$V_{g3,g5}$	250 V	2
Grid 2 voltage	V_{g2}	300 V	
Grid 1 voltage for picture cut-off (no blanking applied)	V_{g1}	-100 to -40 V	
Blanking voltage, peak-to-peak when applied to grid 1		75 V	
when applied to the cathode		20 V	
Flux density of adjustable alignment magnets		0 to 0,4 mT	

PERFORMANCE

	min.	typ.	max.	
Signal electrode voltage for dark current of 10 nA	V_{as} 10		V	
Signal current faceplate illumination 10 lx c.t. 2856 K, dark current 10 nA	I_s	120	nA	
Decay: residual signal current 60 ms after cessation of the illumination (c.t. 2858 K, initial signal current 100 nA, dark current 10 nA)		20	%	
Limiting resolution at picture centre		480	TV lines	2
Average γ of transfer characteristic for signal currents between 10 and 100 nA (see Fig. 1)	0,55	0,74	0,85	
Spurious signals (spots and blemishes)				3

Notes see next page.

Notes

- Grid 6 voltage must always be higher than grids 3 + 5 voltage. The recommended voltage ratio of grid 6 to grids 3 + 5 both for best geometry and most uniform signal output current depends upon the type of coil used and will be 2 : 1 for the recommended type (see "Accessories").
- On EIA resolution test chart, faceplate illumination adjusted for peak signal current of 100 nA and dark current of 10 nA.
- Conditions:

The camera focused on a uniformly illuminated two-zone test pattern, the diameter of the centre zone (1) being equal to the raster height. Zone (2) being defined as the remainder of the scanned area. Signal electrode voltage adjusted for a dark current of 10 nA, illumination (c.t. 2856K) adjusted to provide a signal current of 100 nA. Beam current adjusted for correct stabilization.

Scanning amplitudes of the monitor adjusted to obtain a raster aspect ratio of 3 : 4.

Monitor set-up and contrast control adjusted for faint raster when lens of camera is capped, and for non-blooming bright raster when lens of camera is uncapped.

Under the above conditions the number and size of the spots visible in the monitor picture will not exceed the limits stated below. Both black and white spots must be counted. Only white and black spots with contrasts $\geq 50\%$ and $\geq 100\%$ respectively (of peak white signal) are taken into account.

Spot size in % of raster height	Maximum number of spots	
	zone 1	zone 2
> 0,8	none	none
$\leq 0,8$ to 0,6	none	1
$\leq 0,6$ to 0,2	2	3
$\leq 0,2$	*	*
total (max.)	4	

* Do not count spots of this size unless concentration causes a smudgy appearance.

a) Minimum separation between any 2 spots greater than 0,4% of raster height a limited to a distance equivalent to 3% of raster height.

b) Tubes are rejected for smudge, lines, streaks, mottled, grainy or uneven background having contrasts $> 50\%$

NEWVICON TUBES

SURVEY NEWVICON[®] TUBES

1 inch - magnetic focusing and deflection

All types 95 mA; 6,3 V

type	mesh	photo conductive layer	quality grade			application
			HI	Ind	MS	
XQ1440	S	Nw	●	●	●	
XQ1442*	S	Nw	—	●	●	* Fibre-optic faceplate
XQ1443**	S	Nw	—	●	●	** Extended near IR response
XQ1444▲	S	Nw	—	●	●	▲ Radiation resistant faceplate
XQ1445	S	Nw	—	●	●	

2/3 inch - magnetic focusing and deflection

XQ1274	S	Nw	●	●	●	
XQ1276**	S	Nw	—	●	●	
XQ1380▲	S	Nw	—	●	●	

2/3 inch - electrostatic focusing and magnetic deflection

XQ1275	S	Nw	●	●	●	
XQ1277▲▲	S	Nw	—	●	●	▲▲ Bipotential electrostatic focusing lens
XQ1278▲▲	S	Nw	●	●	●	
XQ1381▲	S	Nw	—	●	●	▲ Radiation resistant faceplate

½ inch - electrostatic focusing and magnetic deflection

XQ1601	S	Nw	—	●	●	107 mA; 2,8 V
XQ1602▲	S	Nw	—	●	●	▲ Radiation resistant faceplate

Accessories for Newvicon tubes

type	deflection (and focusing) coil unit	sockets
XQ1440, XQ1442, XQ1443 XQ1444 XQ1445	KV9G AT1116/06S or equivalent	} 56098 } or equivalent
XQ1274, XQ1276, XQ1380 XQ1275, XQ1277, XQ1278 XQ1381	KV12S or equivalent KV19G or equivalent	} 56098 } or equivalent
XQ1601, XQ1602	KV29E or equivalent	56600

Abbreviations used in the tables

S = separate mesh

Nw = cadmium and zinc telluride layer (Newvicon tubes)

HI = for high-quality black and white and colour cameras in sub-broadcast, medical, educational and industrial applications

Ind = for black and white and colour cameras in non-critical industrial applications

MS = in cameras for military, surveillance, and scientific applications

® Newvicon is a registered trade mark for television camera tubes.

GENERAL OPERATIONAL NOTES

1 PROPERTIES OF THE NEWVICON PHOTOCONDUCTIVE LAYER

The Newvicon photoconductive layer is a heterojunction layer, consisting of a sublayer of zinc selenide (ZnSe) and a sublayer formed by a mixture of zinc telluride (ZnTe) and cadmium telluride (CdTe). In the Newvicon tubes described in this Data Handbook two layer variants are found, differing mainly in spectral response and sensitivity in the infrared region.

1.1 Sensitivity

The Newvicon tube has a high sensitivity in the entire visible spectral region. The sensitivity for white light (colour temperature 2856 K) filtered by an infrared eliminating filter, type B1/K1, is 3 to 4 times as high as that of a Plumbicon® tube.

The light transfer characteristic of the Newvicon tube is linear, except for a slight saturation in the high signal current region.

1.2 Spectral response

Typical spectral responses of the two Newvicon layers are found in Fig. 1.

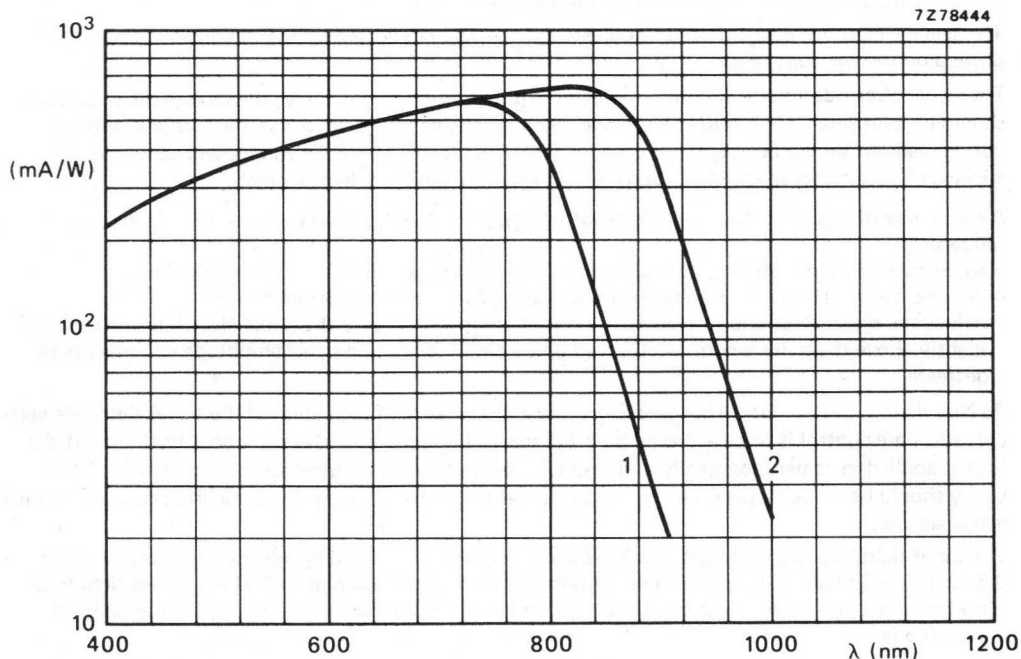

Fig. 1 Typical Newvicon spectral response curves. Curve 1: XQ1274, XQ1275, XQ1278, XQ1380, XQ1381, XQ1440, XQ1442, XQ1444. Curve 2: XQ1276, XQ1277, XQ1443.

® Registered trade mark for television camera tubes.

1.3 Dark current

The dark current in a Newwicon tube is lower than in a vidicon, but it is not negligible. A typical value at 30 °C for a 2/3-inch tube is 5 nA; for a 1-inch tube: 10 nA.

Roughly, the dark current doubles with every 7 to 8 °C temperature increase.

1.4 Resolution

The resolution of a Newwicon tube is determined mainly by the construction of the electron gun and by the operating conditions. Typical modulation transfer characteristics are given in the data sheets.

1.5 Lag

Because of its much larger target capacitance, the lag of a Newwicon tube is significantly higher than that of a Plumbicon tube. As it does not show photoconductive lag like vidicons, however, a Newwicon tube is faster than a vidicon.

Typical values of decay at 200 nA signal current can be found in the data sheets.

1.6 Stray light

The reflectance of the photoconductive layer in a Newwicon tube being low, halation effects in the faceplate of the tube are practically negligible.

1.7 Burn-in

In normal operating conditions, Newwicon tubes show negligible burn-in.

2 EQUIPMENT DESIGN AND OPERATING CONDITIONS

The signal electrode voltage should be adjusted to the value indicated by the tube manufacturer as printed on the envelope ($E_{sj} = \dots V$).

The signal electrode voltage should be adjusted within a tolerance of $\pm 2 V$; the voltage drop across R_1 should be kept small. In the case of cathode blanking, the voltage drop across the cathode resistor during read-out should be taken into account. Too low a signal electrode voltage will cause picture sticking effects, whereas too high a voltage may result in picture defects (spots).

A ready way of adjusting the signal electrode voltage, which usually gives satisfactory results, is as follows:

- apply an even illumination to the target, resulting in a signal current of about 150 nA;
- increase the signal electrode voltage until a grainy structure just becomes visible;
- reduce the signal electrode voltage by 5 V, or, alternatively, reduce the signal electrode voltage until slightly above the point where, as observed on an oscilloscope, the signal amplitude commences to decrease.

As Newwicon tubes do not permit sensitivity control by means of regulation of the signal electrode voltage, adequate control is to be achieved by other means (iris control and neutral density filters). If the tube is applied in cameras originally designed for vidicon tubes, the automatic sensitivity control circuitry should be made inoperative and the signal electrode voltage set to the value indicated by the tube manufacturer.

The input light level on the target of a 2/3-inch Newwicon tube should be adjusted at approximately 0,8 lx at the highlight level of the scene. This means that a signal current of 200 nA at highlight level is preferred for optimum operation. For a 1-inch tube the input light level should be set at approximately 0,5 lx.

If the solar image, or a spot image of similar intensity, is focused on the target through a lens opening wider than $f : 11$, instantaneous breakdown of the target will occur. If it is possible that such a situation may arise, protection measures are necessary, e.g. a lens cap, a neutral density filter or a shutter.

The temperature of the faceplate should not exceed 70 °C, neither during operation nor storage. Whilst dark current doubles at every 7 to 8 °C temperature increase, lag decreases and resolution remains practically constant.

CAMERA TUBE

NEWVICON® television camera tube with a photoconductive target composed of cadmium and zinc tellurides featuring high resolution and an extremely high sensitivity.

The XQ1274 is a 2/3 in diameter camera tube with low heater power, separate mesh, magnetic focusing and deflection, and is mechanically interchangeable with vidicons like the XQ1271 and has the same pin connections.

The XQ1274 is intended for use in ultra-compact cameras for security and surveillance applications, for example, where its high sensitivity and resolution, small size and low power consumption are essential.

QUICK REFERENCE DATA

Separate mesh	
Focusing	magnetic
Deflection	magnetic
Diameter	17,7 mm
Length	max. 108 mm
Special response, max. at	approx. 750 nm
cut-off at	approx. 900 nm
Heater	6,3 V, 95 mA
Limiting resolution	650 TV lines

OPTICAL

Diagonal of quality rectangle on photoconductive layer (aspect ratio 3 : 4) 11 mm

Orientation of image on photoconductive layer:

The direction of the horizontal scan should be essentially parallel to the plane passing through the longitudinal tube axis and pin 4.

Spectral response, curve see Fig. 1

Faceplate thickness	1,5 mm
refractive index	1,61

HEATING Indirect by a.c. or d.c.; parallel or series supply

Heater voltage	V_f	6,3 V \pm 10%
Heater current, at $V_f = 6,3$ V	I_f	95 mA

When the tube is used in a series heater chain, the heater voltage must not exceed an r.m.s. value of 9,5 V when the supply is switched on.

XQ1274

CAPACITANCES

Signal electrode to all

$$C_{as} \approx 2 \text{ pF}$$

This capacitance, which is effectively the output impedance of the tube, increases when the tube is inserted into the deflection and focusing coil unit.

MECHANICAL DATA

Dimensions in mm

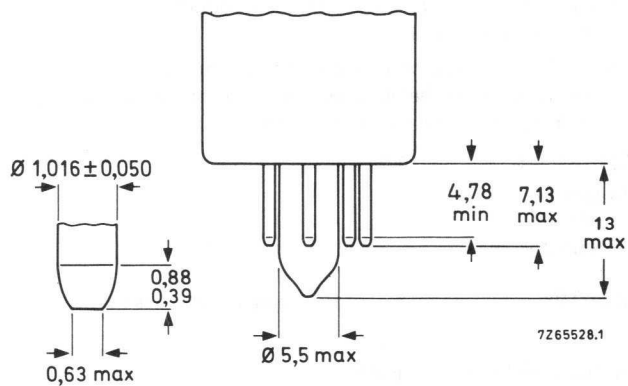
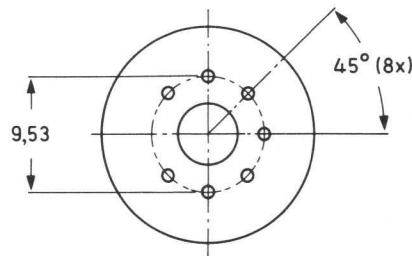
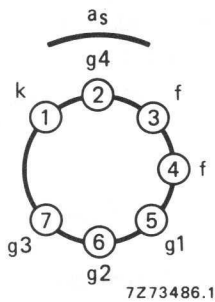
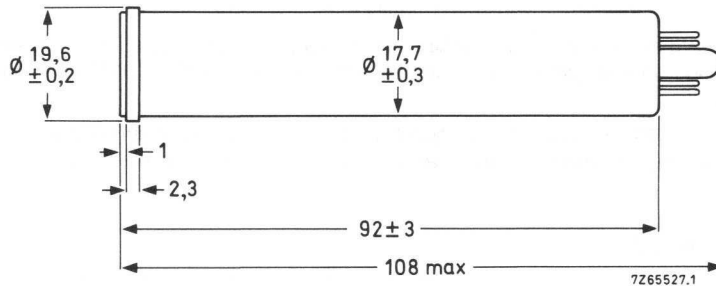

Mounting position: any

Net mass: $\approx 23 \text{ g}$

Base: JEDEC no. E7-91

ACCESSORIES

Socket	special miniature 7-pin, type 56049 or equivalent
Deflection and focusing coil unit	KV12S or equivalent

DEFLECTION

magnetic

FOCUSING

magnetic

LIMITING VALUES (Absolute maximum rating system)

for a scanned area of 6,6 mm x 8,8 mm.

"Full-size scanning" i.e. scanning of a 6,6 mm x 8,8 mm area of the photoconductive layer should always be applied. Underscanning, i.e. scanning of an area smaller than 6,6 mm x 8,8 mm, may cause permanent damage to the specified full-size area.

Signal electrode voltage	V_{as}	max.	50 V *
Grid 4 voltage	V_{g4}	max.	750 V
Grid 3 voltage	V_{g3}	max.	750 V
Grid 2 voltage	V_{g2}	max.	350 V
Grid 1 voltage, negative	$-V_{g1}$	max.	300 V
positive	V_{g1}	max.	0 V
Cathode-to-heater voltage, peak positive	V_{kfp}	max.	125 V
peak negative	$-V_{kfp}$	max.	10 V
Output current, peak	I_{asp}	max.	800 nA**
Faceplate illumination	E	max.	10 000 lx ▲
Faceplate temperature, storage and operation	T	max.	70 °C
Cathode heating time before drawing cathode current	t_h	min.	1 min

* Newvicon tubes do not permit automatic sensitivity control by means of regulation of the signal electrode voltage. Adequate control is therefore to be achieved by other means (iris control and neutral density filters). If the tube is applied in cameras originally designed for vidicon tubes, the automatic sensitivity control circuitry should be made inoperative and the signal electrode voltage set to the value indicated by the tube manufacturer, see also General Operational Notes.

** Video amplifiers should be capable of handling signal-electrode currents of this magnitude without overloading the amplifier or distorting the picture.

▲ White light, uniformly diffused over entire tube face.

Care must be taken not to focus the solar image on the target through a lens opening wider than $f : 11$ to avoid instantaneous breakdown.

OPERATING CONDITIONS AND PERFORMANCE

for a scanned area of 6,6 mm x 8,8 mm, a faceplate temperature of 25 to 35 °C
and standard TV scanning rate

Conditions			notes
Signal electrode voltage	V_{as}	10 to 35 V	1
Grid 4 (decelerator) voltage	V_{g4}	400 V	2
Grid 3 (beam focus electrode) voltage	V_{g3}	300 V	3
Grid 2 (accelerator) voltage	V_{g2}	300 V	
Grid 1 voltage for picture cut-off (no blanking applied)	V_{g1}	-80 to -35 V	
Blanking voltage, peak to peak			
when applied to grid 1		75 V	
when applied to cathode		20 V	
Flux density at centre of focusing coil		5,0 to 5,6 mT	
Flux density of adjustable alignment coils or magnets		0 to 0,4 mT	
Performance		min.	typ.
Dark current (at 25 °C)			2
Signal current, white light faceplate illumination 1 lx c.t. 2856 K	I_s	200	260
Decay: residual signal current 60 ms after cessation of the illumination initial signal current 200 nA			8
Limiting resolution, at picture centre		550	650
at picture corners		350	450
Average γ of transfer characteristic, see Fig. 2			≈ 1
Spurious signals (spots and blemishes)			5

Notes

1. The signal electrode voltage should be adjusted to the value indicated by the tube manufacturer as printed on the envelope ($E_{sj} = \dots V$). To minimize picture sticking effects the signal electrode should be adjusted within a tolerance of $\pm 2 V$; the voltage drop across R_1 should be kept small. In case of cathode blanking the voltage drop across the cathode resistor during read-out should be taken into account.
2. Grid 4 voltage must always be higher than grid 3 voltage. The recommended ratio of grid 4 voltage to grid 3 voltage both for best geometry and most uniform signal output depends upon the type of coil unit used and will be 4 : 3 for the recommended type (see 'Accessories').
3. Resolution decreases with decreasing grid 3 voltage. In general grid 3 should be operated above 250 V.
4. On EIA resolution test chart; faceplate illumination adjusted for a peak output current of 200 nA.
5. **Conditions**

The camera focused on a uniformly illuminated two-zone test pattern, the diameter of the centre zone (1) being equal to the raster height. Zone (2) being defined as the remainder of the scanned area.

Faceplate illumination adjusted to produce 200 nA signal current, beam current adjusted for correct stabilization.

Monitor set-up and contrast control adjusted for faint raster when lens of camera is capped and for non-blooming bright raster when lens of camera is uncapped.

Under above conditions the number and size of spots per zone visible in the monitor picture will not exceed the limits stated below. Both black and white spots must be counted, unless their contrast is less than 50% of peak white signal as observed on a waveform oscilloscope. Spots having a contrast $\geq 100\%$ are fully counted, spots having a contrast $> 50\%$ but $< 100\%$ will be considered as having half their actual size.

Spot size in % of raster height	Maximum number of spots	
	zone 1	zone 2
$> 1,2$	none	none
$\leq 1,0$ to 0,8	none	1
$\leq 0,8$ to 0,4	4	4
$\leq 0,4$ to 0,2	4	4
$\leq 0,2$	*	*
total (max.)	8	

* Do not count spots of this size unless concentration causes a smudgy appearance.
Tubes are rejected for: smudges, lines, streaks, mottled, grainy or uneven background having contrast $> 50\%$.

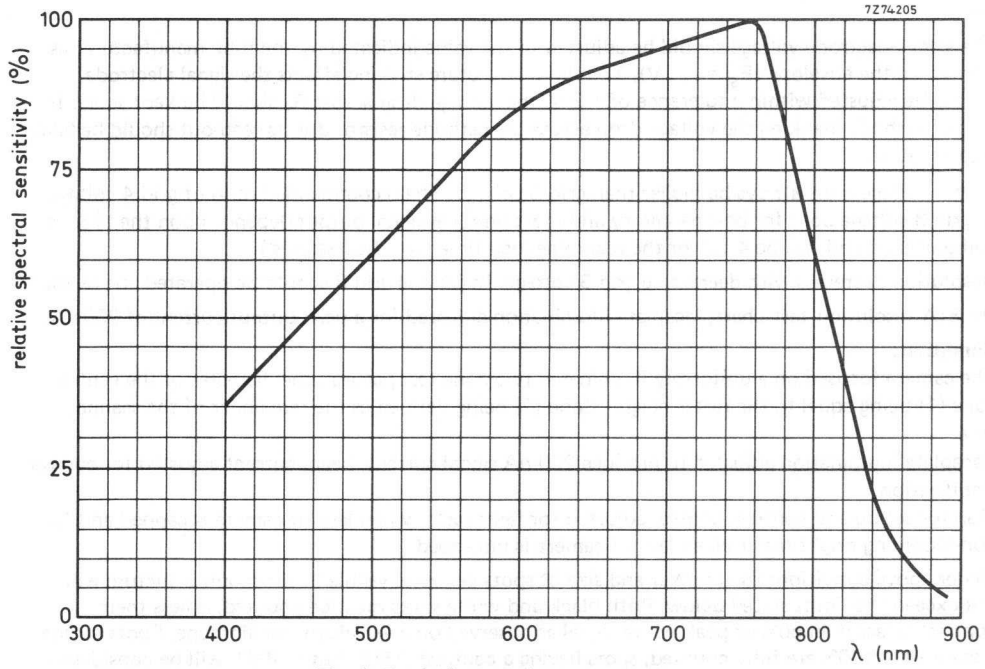

Fig. 1 Typical spectral response curve.

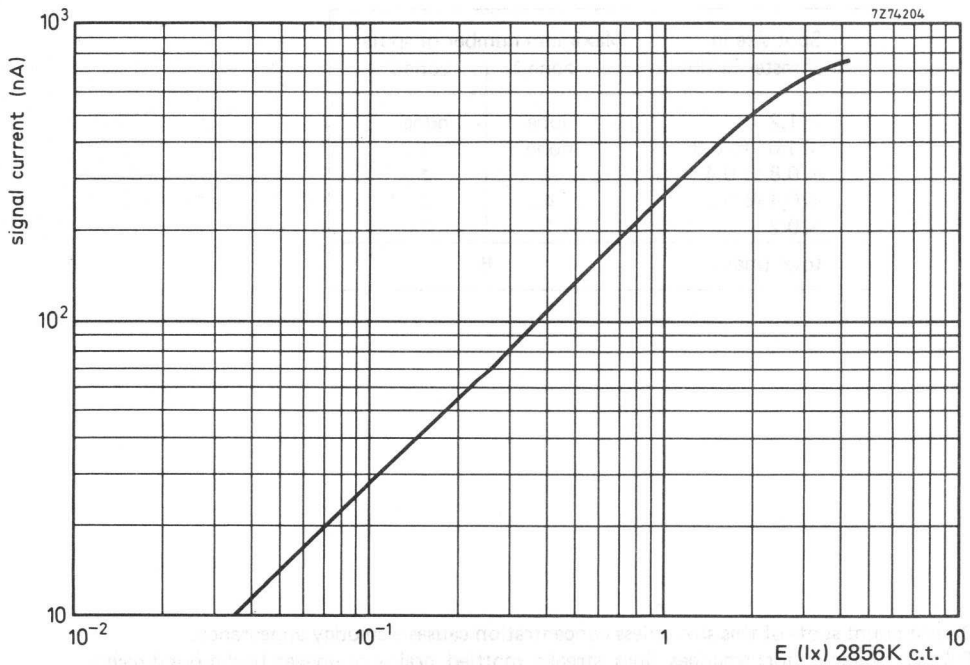

Fig. 2 Typical light transfer characteristic.

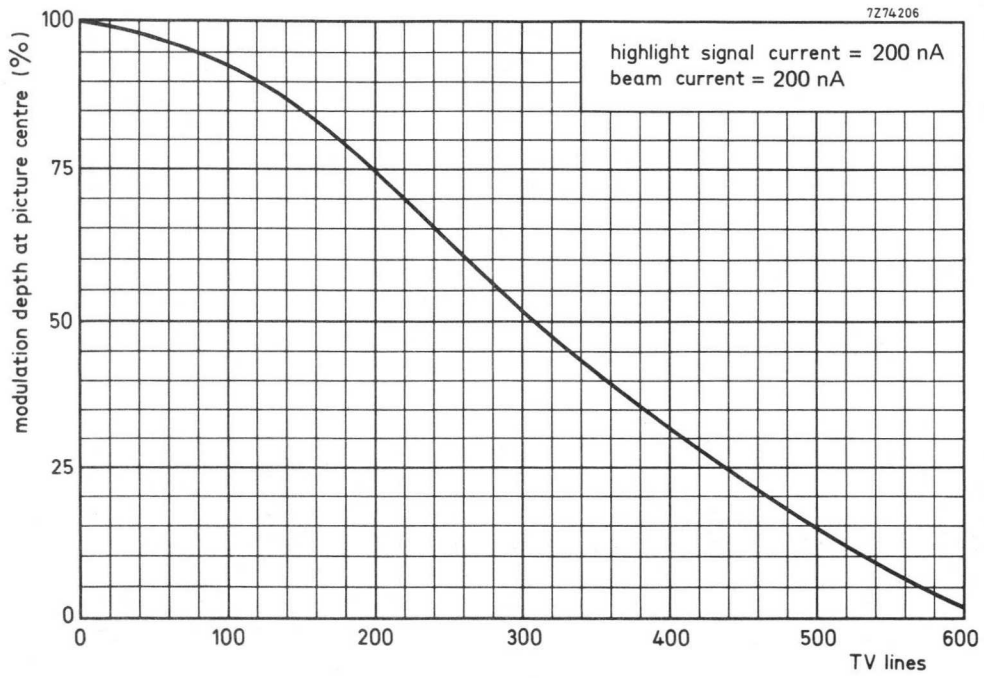

Fig. 3 Typical uncompensated square wave response curve.

CAMERA TUBE

NEWVICON® television camera tube with a photoconductive target composed of cadmium and zinc tellurides featuring high resolution and an extremely high sensitivity.

The XQ1275 is a 2/3 in diameter camera tube with low heater power, separate mesh, electrostatic focusing and magnetic deflection. It is mechanically interchangeable with vidicons like XQ1272 and has the same pin connections.

The XQ1275 is intended for use in ultra-compact cameras for security and surveillance applications, for example, where its high sensitivity and resolution, small size and low power consumption are essential.

QUICK REFERENCE DATA

Separate mesh	
Focusing	electrostatic
Deflection	magnetic
Diameter	17,7 mm
Length	max. 108 mm
Spectral response, max. at	approx. 750 nm
cut-off at	approx. 900 nm
Heater	6,3 V, 95 mA
Limiting resolution	600 TV lines

OPTICAL

Diagonal of quality rectangle on photoconductive layer (aspect ratio 3 : 4) 11 mm

Orientation of image on photoconductive layer:

The direction of the horizontal scan should be essentially parallel to the plane passing through the longitudinal tube axis and pin 4.

Spectral response, curve see Fig. 1

Faceplate thickness	1,5 mm
refractive index	1,61

HEATING Indirect by a.c. or d.c.; parallel or series supply

Heater voltage	V_f	6,3 V \pm 10%
Heater current, at $V_f = 6,3$ V	I_f	95 mA

When the tube is used in a series heater chain, the heater voltage must not exceed an r.m.s. value of 9,5 V when the supply is switched on.

® Registered trade mark for television camera tubes.

CAPACITANCES

Signal electrode to all

$$C_{as} \approx 2 \text{ pF}$$

This capacitance, which is effectively the output impedance of the tube, increases when the tube is inserted into the deflection unit.

MECHANICAL DATA

Dimensions in mm

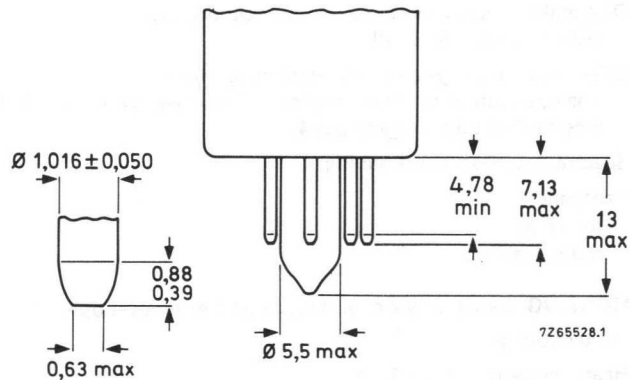
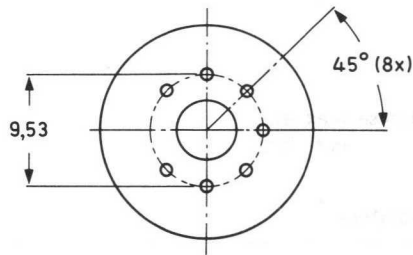
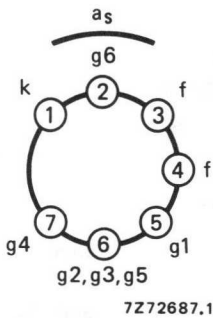
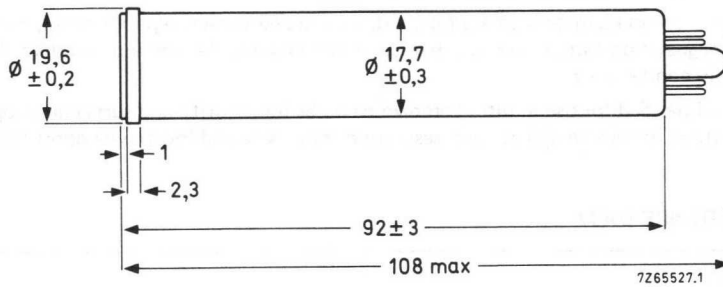

Mounting position: any

Net mass: $\approx 25 \text{ g}$

Base: JEDEC no. E7-91

ACCESSORIES

Socket	special miniature 7-pin, type 56049 or equivalent
Deflection coil unit	KV19G or equivalent

DEFLECTION

magnetic

FOCUSING

electrostatic (unipotential focusing electron optics)

LIMITING VALUES (Absolute max. rating system)
for a scanned area of 6,6 mm x 8,8 mm.

"Full-size scanning" i.e. scanning of a 6,6 mm x 8,8 mm area of the photoconductive layer should always be applied. Underscanning, i.e. scanning of an area smaller than 6,6 mm x 8,8 mm, may cause permanent damage to the specified full-size area.

Signal electrode voltage	V_{as}	max.	50 V *
Grid 6 voltage	V_{g6}	max.	600 V
Grid 4 (beam focus electrode) voltage	V_{g4}	max.	350 V
Grid 2, 3 and 5 voltage	$V_{g2, 3 + 5}$	max.	350 V
Grid 1 voltage, negative	$-V_{g1}$	max.	300 V
	V_{g1}	max.	0 V
Cathode-to-heater voltage, peak positive	V_{kfp}	max.	125 V
	$-V_{kfp}$	max.	10 V
Output current, peak	I_{asp}	max.	800 nA **
Faceplate illumination	E	max.	10 000 lx ▲
Faceplate temperature, storage and operation	T	max.	70 °C
Cathode heating time before drawing cathode current	t_h	min.	1 min

* Newwicon tubes do not permit automatic sensitivity control by means of regulation of the signal electrode voltage. Adequate control is therefore to be achieved by other means (iris control and neutral density filters). If the tube is applied in cameras originally designed for vidicon tubes, the automatic sensitivity control circuitry should be made inoperative and the signal electrode voltage set to the value indicated in the test sheet. See General Operational Notes.

** Video amplifiers should be capable of handling signal electrode currents of this magnitude without overloading the amplifier or distorting the picture.

▲ White light, uniformly diffused over entire tube face.
Care must be taken not to focus the solar image on the target through a lens opening wider than $f : 11$ to avoid instantaneous breakdown.

OPERATING CONDITIONS AND PERFORMANCE

for a scanned area of 6,6 mm x 8,8 mm, a faceplate temperature of 25 to 35 °C and standard TV scanning rate.

Conditions

			notes
Signal electrode voltage	V_{as}	10 to 35 V	1
Grid 6 (decelerator) voltage	V_{g6}	500 V	2
Grid 4 (beam focus electrode) voltage	V_{g4}	35 to 55 V	3
Grid 2, 3 and 5 voltage	V_{g2+3+5}	300 V	2,4
Grid 1 voltage for picture cut off (no blanking applied)	V_{g1}	-80 to -30 V	
Blanking voltage, peak to peak			
when applied to grid 1		75 V	
when applied to cathode		20 V	
Flux density of adjustable alignment coil or magnet		0 to 0,4 mT	

Performance

		min.	typ.	max.	
Dark current (at 25 °C)			2	4	nA
Signal current, white light faceplate illumination 1 lx c.t. 2856 K	I_s	200	260		nA
Decay: residual signal current 60 ms after cessation of the illumination initial signal current 200 nA			10	15	%
Limiting resolution, at picture centre		500	600		TV lines 5
at picture corners		350	450		TV lines 5
Average γ of transfer characteristic, see Fig. 2			≈ 1		
Spurious signals (spots and blemishes)					6

Notes

1. The signal electrode voltage should be adjusted to the value indicated by the tube manufacturer as printed on the envelope ($E_{sj} = \dots V$). To minimize picture sticking effects the signal electrode should be adjusted within a tolerance of $\pm 2 V$; the voltage drop across R_1 should be kept small. In the case of cathode blanking the voltage drop across the cathode resistor during read-out should be taken into account.
2. Grid 6 voltage must always be higher than grids 2 + 3 + 5 voltage.
The recommended ratio of grid 6 voltage to grids 2 + 3 + 5 voltage for best geometry and most uniform signal output depends upon the type of coil used and will be 5 : 3 for the recommended type (see "Accessories").
3. Adjusted for correct electrical focus.
4. Grids 2 + 3 + 5 voltage should be $> 250 V$ to provide sufficient beam current.
5. On EIA resolution test chart: faceplate illumination adjusted for a peak output current of 200 nA. The resolution is highly dependent on the coil used; the indicated figures are only valid for the recommended coil.

6. Conditions

The camera focused on a uniformly illuminated two-zone test pattern, the diameter of the centre zone (1) being equal to the raster height. Zone (2) being defined as the remainder of the scanned area.

Faceplate illumination adjusted to produce 200 nA signal current, beam current adjusted for correct stabilization.

Monitor set-up and contrast control adjusted for faint raster when lens of camera is capped and for non-blooming bright raster when lens of camera is uncapped.

Under above conditions the number and size of spots per zone visible in the monitor picture will not exceed the limits stated below. Both black and white spots must be counted, unless their contrast is less than 50% of peak white signal as observed on a waveform oscilloscope. Spots having a contrast $\geq 100\%$ are fully counted, spots having a contrast $> 50\%$ but $< 100\%$ will be considered as having half their actual size.

Spot size in % of raster height	Maximum number of spots	
	zone 1	zone 2
$> 1,2$	none	none
$\leq 1,0$ to 0,8	none	1
$\leq 0,8$ to 0,4	4	4
$\leq 0,4$ to 0,2	4	4
$\leq 0,2$	*	*
total (max.)	8	

* Do not count spots of this size unless concentration causes a smudgy appearance.

Tubes are rejected for: smudges, lines, streaks, mottled, grainy or uneven background having contrast $> 50\%$.

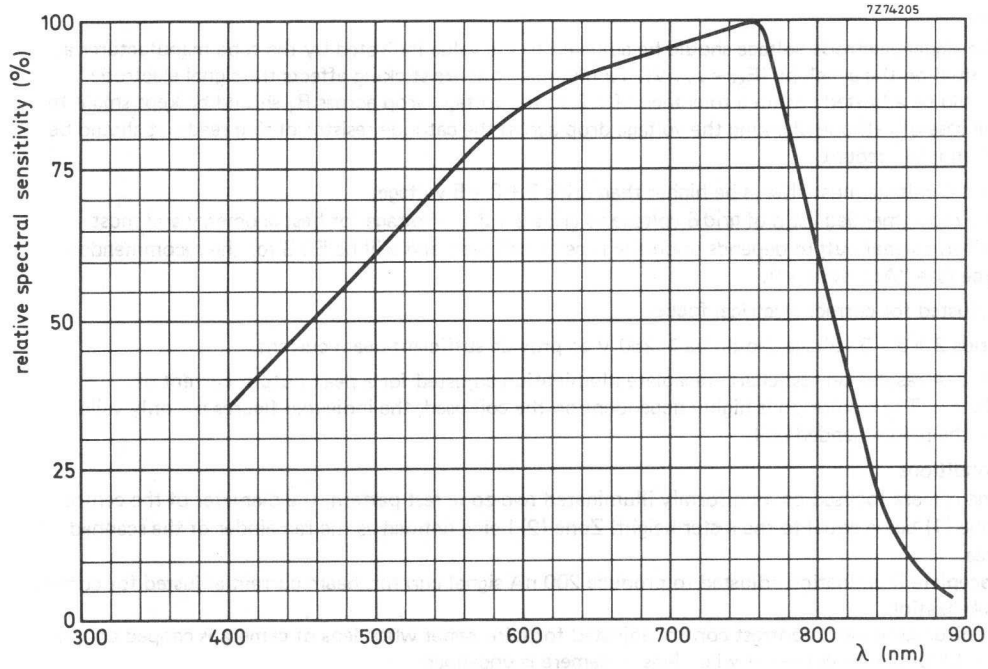

Fig. 1 Typical spectral response curve.

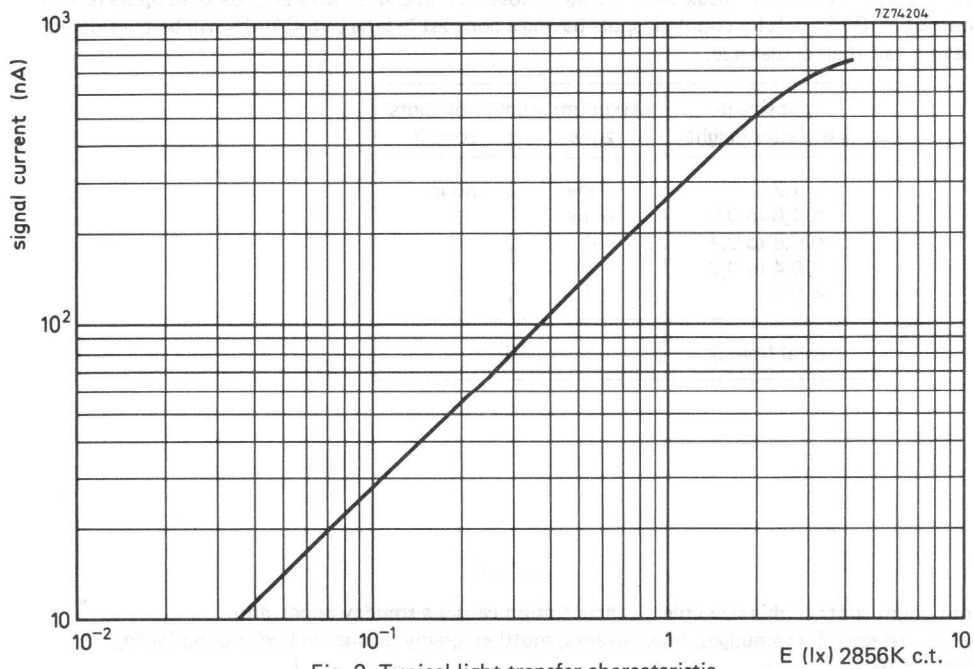

Fig. 2 Typical light transfer characteristic.

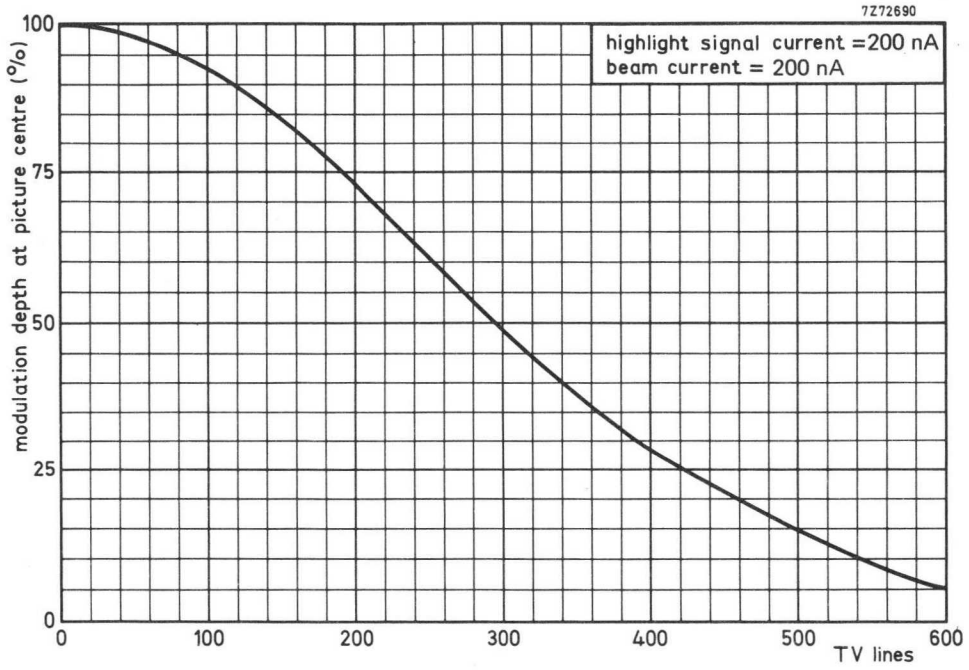

Fig. 3 Typical uncompensated square wave response curve.
 Focusing electrostatic and magnetic combined.

CAMERA TUBE

NEWVICON® television camera tube with a photoconductive target composed of cadmium and zinc tellurides featuring high resolution and an extremely high sensitivity extending into the near infrared region.

The XQ1276 is a 2/3 in diameter camera tube with low heater power, separate mesh, magnetic focusing and deflection, and is mechanically interchangeable with vidicons like the XQ1271 and Newvicon tubes XQ1274 and has the same pin connections.

The XQ1276 is intended for use in ultra-compact cameras for security and surveillance applications, for example, where its high sensitivity extending into the near infrared, and its high resolution, small size and low power consumption are essential.

QUICK REFERENCE DATA

Separate mesh	
Focusing	magnetic
Deflection	magnetic
Diameter	17,7 mm
Length	max. 108 mm
Spectral response, max. at	approx. 775 nm
cut-off at	approx. 1000 nm
Heater	6,3 V, 95 mA
Limiting resolution	650 TV lines

OPTICAL

Diagonal of quality rectangle on photoconductive layer
(aspect ratio 3 : 4) 11 mm

Orientation of image on photoconductive layer:

The direction of the horizontal scan should be essentially parallel to the plane passing through the longitudinal tube axis and pin 4.

Spectral response curve see Fig. 1.

Face plate thickness	1,5 mm
refractive index	1,61

HEATING Indirect by a.c. or d.c.; parallel or series supply

Heater voltage	V_f	6,3 V \pm 10%
Heater current at $V_f = 6,3$ V	I_f	95 mA

When the tube is used in a series heater chain, the heater voltage must not exceed an r.m.s. value of 9,5 V when the supply is switched on.

® Registered trade mark for television camera tubes.

CAPACITANCES

Signal electrode to all

$$C_{as} \approx 2 \text{ pF}$$

This capacitance, which is effectively the output impedance of the tube, increases when the tube is inserted into the deflection and focusing coil unit.

MECHANICAL DATA

Dimensions in mm

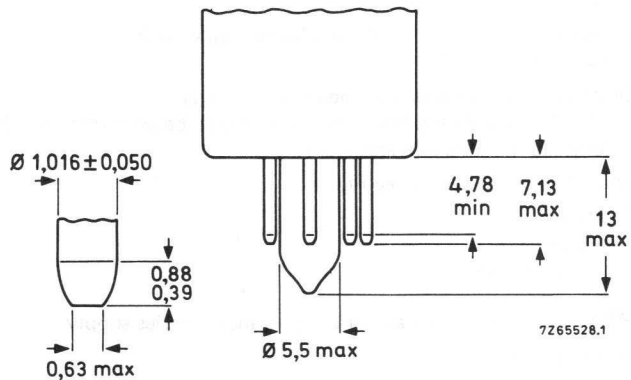
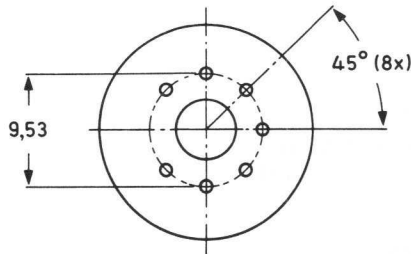
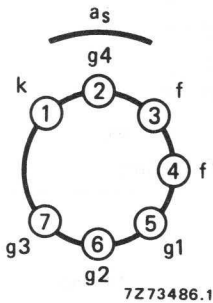
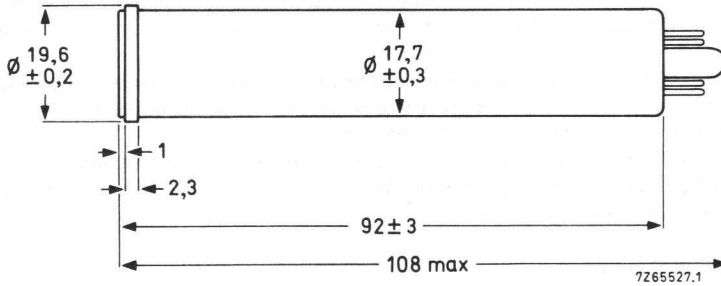

Mounting position: any

Net mass: $\approx 23 \text{ g}$

Base: JEDEC no. E7-91.

ACCESSORIES

Socket	special miniature 7-pin, type 56049 or equivalent
Deflection and focusing coil unit	KV12S or equivalent

DEFLECTION

magnetic

FOCUSING

magnetic

LIMITING VALUES (Absolute maximum rating system)

for a scanned area of 6,6 mm x 8,8 mm.

"Full-size scanning" i.e. scanning of a 6,6 mm x 8,8 mm area of the photoconductive layer should always be applied. Underscanning, i.e. scanning of an area smaller than 6,6 mm x 8,8 mm, may cause permanent damage to the specified full-size area.

Signal electrode voltage	V_{as}	max.	50 V*
Grid 4 voltage	V_{g4}	max.	750 V
Grid 3 voltage	V_{g3}	max.	750 V
Grid 2 voltage	V_{g2}	max.	350 V
Grid 1 voltage, negative	$-V_{g1}$	max.	300 V
positive	V_{g1}	max.	0 V
Cathode-to-heater voltage, peak positive	V_{kfp}	max.	125 V
peak negative	$-V_{kfp}$	max.	10 V
Output current, peak	I_{asp}	max.	800 nA**
Faceplate illumination	E	max.	10 000 lx ▲
Faceplate temperature, storage and operation	T	max.	60 °C
Cathode heating time before drawing cathode current	t_h	min.	1 min

* Newwicon tubes do not permit automatic sensitivity control by means of regulation of the signal electrode voltage. Adequate control is therefore to be achieved by other means (iris control and neutral density filters). If the tube is applied in cameras originally designed for vidicon tubes, the automatic sensitivity control circuitry should be made inoperative and the signal electrode voltage set to the value indicated by the tube manufacturer. See General Operational Notes.

** Video amplifiers should be capable of handling signal-electrode currents of this magnitude without overloading the amplifier or distorting the picture.

▲ White light, uniformly diffused over entire tube face.

Care must be taken not to focus the solar image on the target through a lens opening wider than $f : 11$ to avoid instantaneous breakdown.

OPERATING CONDITIONS AND PERFORMANCE

for a scanned area of 6,6 mm x 8,8 mm, a faceplate temperature of 25 to 35 °C and standard TV scanning rate.

Conditions

			notes
Signal electrode voltage	V_{as}	10 to 25 V	1
Grid 4 (decelerator) voltage	V_{g4}	400 V	2
Grid 3 (beam focus electrode) voltage	V_{g3}	300 V	3
Grid 2 (accelerator) voltage	V_{g2}	300 V	
Grid 1 voltage for picture cut-off (no- blanking applied)	V_{g1}	-80 to -35 V	
Blanking voltage, peak to peak			
when applied to grid 1		75 V	
when applied to cathode		20 V	
Flux density at centre of focusing coil		5,0 to 5,6 mT	
Flux density of adjustable alignment coil or magnet		0 to 0,4 mT	

Performance

	min.	typ.	max.	
Dark current (at 25 °C)		5	10 nA	
Signal current, white light faceplate illumination 1 lx c.t. 2856 K	I_s 250	320	nA	
Signal current, near infrared illumination 1 lx, c.t. 2856 K infrared transmitting filter interposed (transmission curve see Fig. 2)	I_s 50	80	nA	
Decay: residual signal current 60 ms after cessation of the illumination initial signal current 200 nA		8	13 %	
Limiting resolution, at picture centre	550	650	TV lines 4	
at picture corners	350	450	TV lines 4	
Average γ of transfer characteristic, see Fig. 3		≈ 1		
Spurious signals (spots and blemishes)				5

Notes

- The signal electrode voltage should be adjusted to the value indicated by the tube manufacturer as printed on the envelope ($E_{sj} = \dots V$).
To minimize picture sticking effects the signal electrode voltage should be adjusted within a tolerance of $\pm 2 V$; the voltage drop across R_1 should be kept small. In case of cathode blanking the voltage drop across the cathode resistor during read-out should be taken into account.
 - Grid 4 voltage must always be higher than grid 3 voltage. The recommended ratio of grid 4 voltage to grid 3 voltage both for best geometry and most uniform signal output depends upon the type of coil unit used and will be 4:3 for the recommended type (see 'Accessories').
 - Resolution decreases with decreasing grid 3 voltage. In general grid 3 should be operated above 250 V.
 - On EIA resolution test chart; faceplate illumination adjusted for a peak output current of 200 nA.
5. Conditions

The camera focused on a uniformly illuminated two-zone test pattern, the diameter of the centre zone (1) being equal to the raster height. Zone (2) being defined as the remainder of the scanned area.

Faceplate illumination adjusted to produce 200 nA signal current, beam current adjusted for correct stabilization.

Monitor set-up and contrast control adjusted for faint raster when lens of camera is capped and for non-blooming bright raster when lens of camera is uncapped.

Under above conditions the number and size of spots per zone visible in the monitor picture will not exceed the limits stated below. Both black and white spots must be counted, unless their contrast is less than 50% of peak white signal as observed on a waveform oscilloscope. Spots having a contrast $\geq 100\%$ are fully counted, spots having a contrast $> 50\%$ but $< 100\%$ will be considered as having half their actual size.

spot size in % of raster height	maximum number of spots	
	zone 1	zone 2
$> 1,2$	none	none
$\leq 1,2$ to 0,8	none	1
$\leq 0,8$ to 0,4	4	5
$\leq 0,4$ to 0,2	5	5
$\leq 0,2$	*	*
total (max.)	5	7

* Do not count spots of this size unless concentration causes a smudgy appearance.

Tubes are rejected for: smudges, lines, streaks, mottled, grainy or uneven background having contrast $> 50\%$.

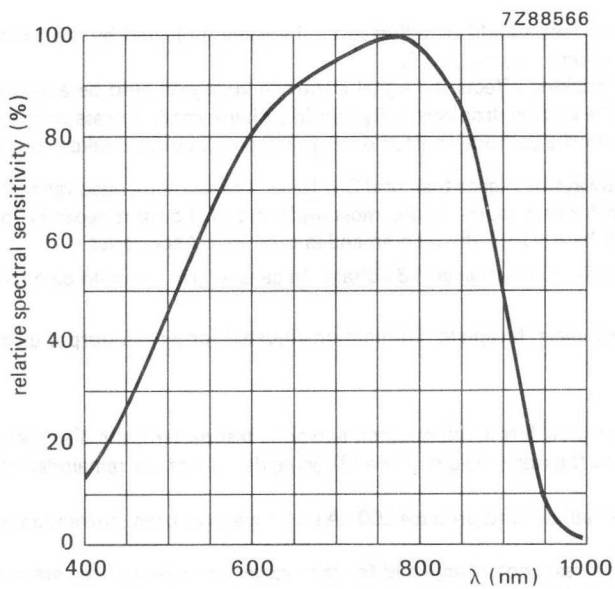

Fig.1 Typical spectral response curve.

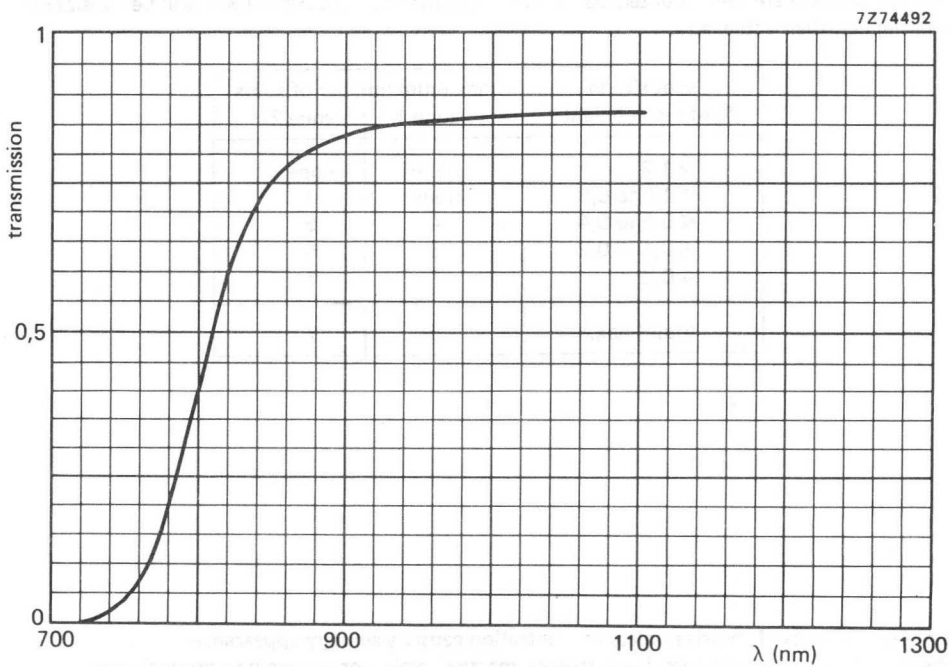

Fig.2 Transmission curve of infrared filter.

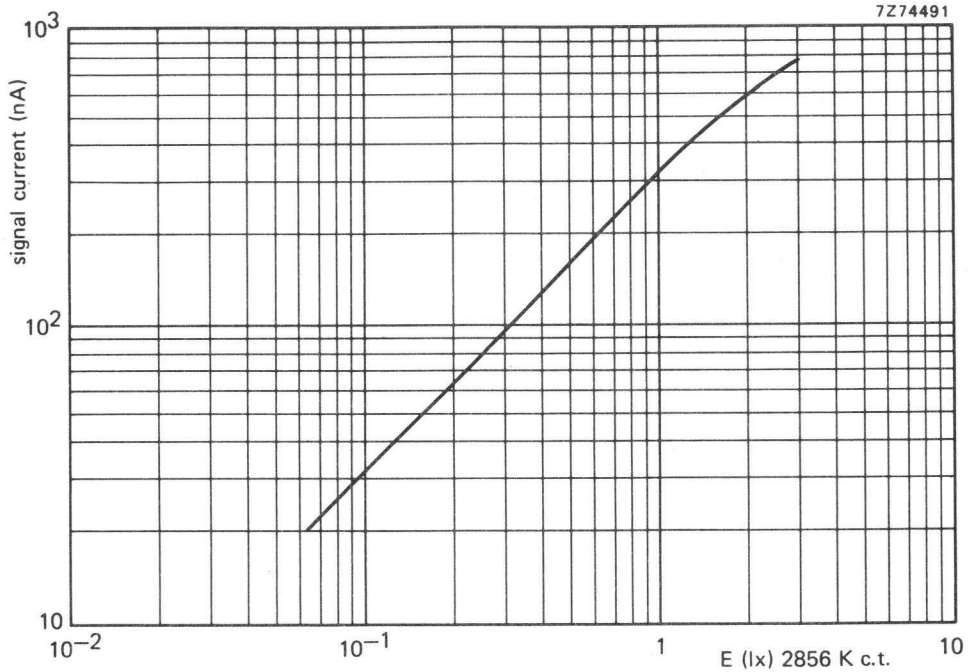

Fig.3 Typical light transfer characteristic.

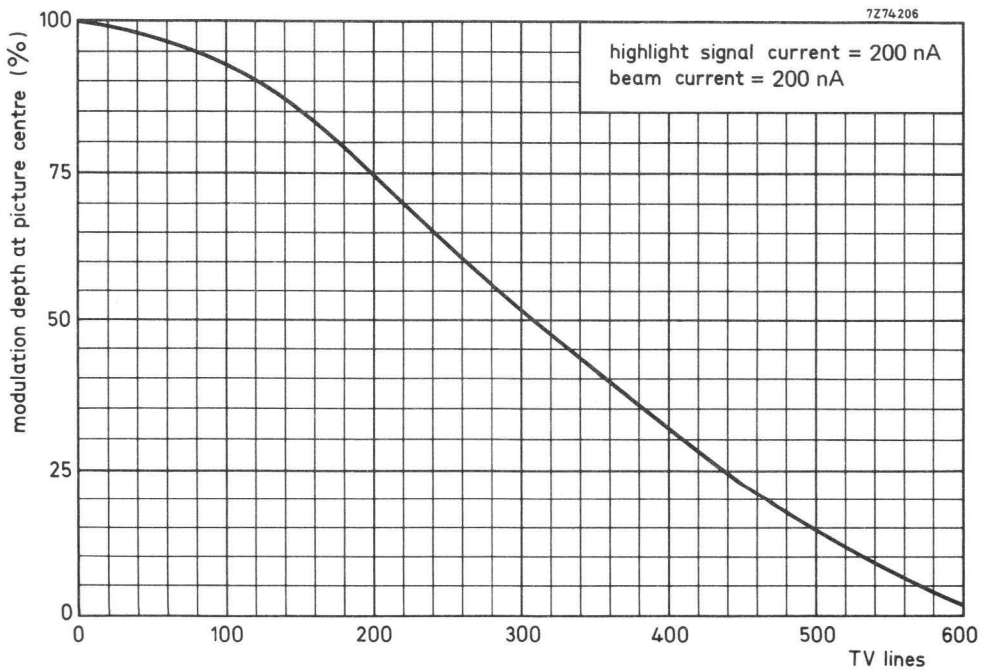

Fig.4 Typical uncompensated square wave response curve.

CAMERA TUBE

NEWVICON® television camera tube with a photoconductive target composed of cadmium and zinc tellurides featuring high resolution and an extremely high sensitivity extending into the near infrared region.

The XQ1277 is a 2/3 in diameter camera tube with low heater power, separate mesh, electrostatic focusing and magnetic deflection and is mechanically interchangeable with vidicons such as XQ1272, XQ1590 and newvicons XQ1275. Pin configuration is similar.

The XQ1277 is intended for use in ultra-compact cameras for security and surveillance applications, for example, where its high sensitivity extending into the near infrared, small size and low power consumption are essential.

QUICK REFERENCE DATA

Separate mesh	
Focusing (bi-potential focusing lens)	electrostatic
Deflection	magnetic
Diameter	17,7 mm
Length	max. 108 mm
Spectral response, max. at	approx. 775 nm
cut-off at	approx. 1000 nm
Heater	6,3 V, 95 mA
Limiting resolution	550 TV lines

OPTICAL

Diagonal of quality rectangle on photoconductive layer (aspect ratio 3 : 4)	11 mm
Orientation of image on photoconductive layer: The direction of the horizontal scan should be essentially parallel to the plane passing through the longitudinal tube axis and pin 4.	
Face plate thickness	1,5 mm
refractive index	1,61
Spectral response, curve see Fig. 1	

HEATING Indirect by a.c. or d.c.; parallel or series supply

Heater voltage	V_f	6,3 V \pm 10%
Heater current at $V_f = 6,3$ V	I_f	95 mA

When the tube is used in a series heater chain, the heater voltage must not exceed an r.m.s. value of 9,5 V when the supply is switched on.

® Registered trade mark for television camera tubes.

CAPACITANCES

Signal electrode to all

$C_{as} \approx 2 \text{ pF}$

This capacitance, which is effectively the output impedance of the tube increases when the tube is inserted into the deflection unit.

MECHANICAL DATA

Dimensions in mm

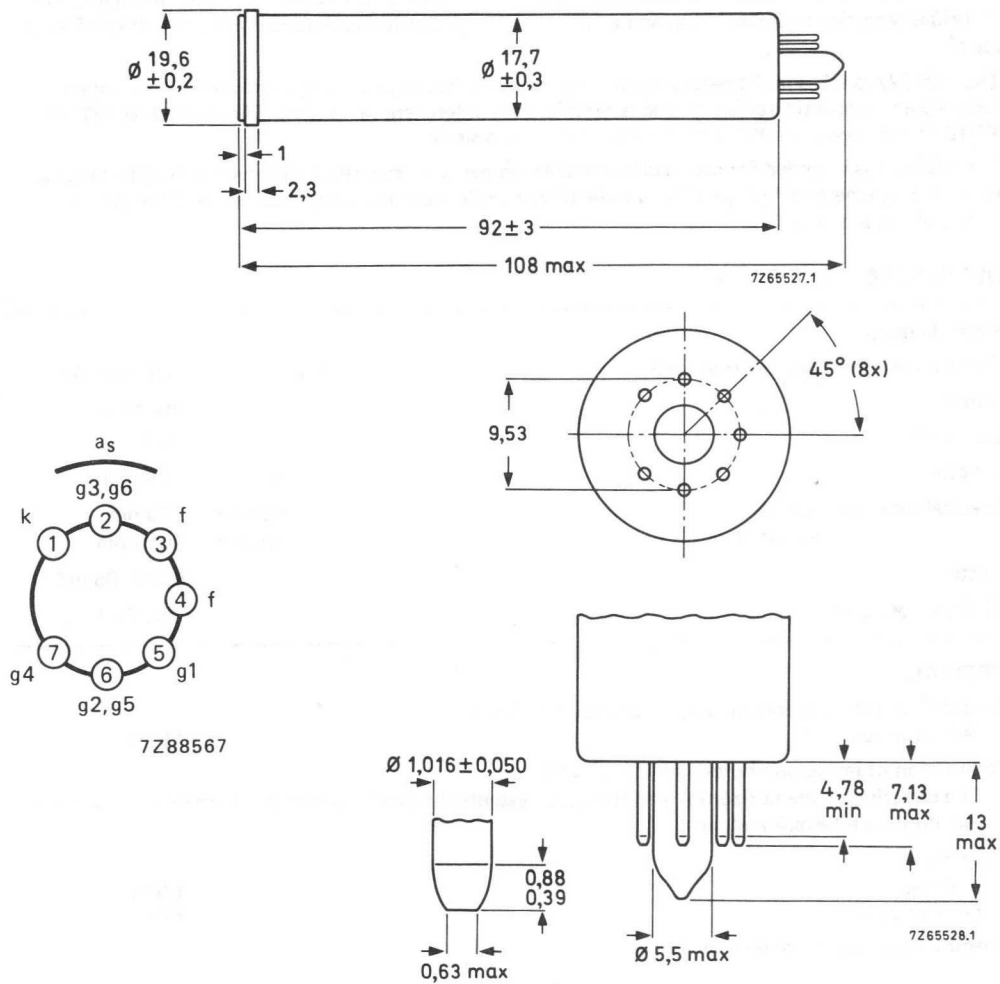

7288567

Mounting position: any

Net mass: $\approx 25 \text{ g}$

Base: JEDEC no. E7-91

ACCESSORIES

Socket

special miniature 7-pin,
type 56049 or equivalent

Deflection coil unit

KV19G or equivalent

DEFLECTION

magnetic

FOCUSINGelectrostatic (bipotential focusing
electron optics)**LIMITING VALUES** (Absolute maximum rating system)

for a scanned area of 6,6 mm x 8,8 mm.

"Full-size scanning" i.e. scanning of a 6,6 mm x 8,8 mm area of the photoconductive layer should always be applied. Underscanning, i.e. scanning of an area smaller than 6,6 mm x 8,8 mm, may cause permanent damage to the specified full-size area.

Signal electrode voltage	V_{as}	max.	50 V*
Grid 3 and 6 voltage	$V_{g3,6}$	max.	750 V
Grid 4 voltage	V_{g4}	max.	350 V
Grid 2 and 5 voltage	$V_{g2,5}$	max.	350 V
Grid 1 voltage, negative	$-V_{g1}$	max.	300 V
positive	V_{g1}	max.	0 V
Cathode-to-heater voltage, peak positive	V_{kfp}	max.	125 V
peak negative	$-V_{kfp}$	max.	10 V
Output current, peak	I_{asp}	max.	800 nA**
Faceplate illumination	E	max.	10 000 lx ▲
Faceplate temperature, storage and operation	T	max.	60 °C
Cathode heating time before drawing cathode current	t_h	min.	1 min

* Newvicon tubes do not permit automatic sensitivity control by means of regulation of the signal electrode voltage. Adequate control is therefore to be achieved by other means (iris control and neutral density filters). If the tube is applied in cameras originally designed for vidicon tubes, the automatic sensitivity control circuitry should be made inoperative and the signal electrode voltage set to the value indicated on the tube. See General Operational Notes.

** Video amplifiers should be capable of handling signal electrode currents of this magnitude without overloading the amplifier or distorting the picture.

▲ White light, uniformly diffused over entire tube face.

Care must be taken not to focus the solar image on the target through a lens opening wider than $f : 11$ to avoid instantaneous breakdown.

OPERATING CONDITIONS AND PERFORMANCE

for a scanned area of 6,6 mm x 8,8 mm, a faceplate temperature of 25 to 35 °C and standard TV scanning rate.

Conditions

			notes
Signal electrode voltage	V_{as}	10 to 25 V	1
Grid 3 and 6 (decelerator) voltage	$V_{g3,6}$	500 V	2
Grid 4 (beam focus electrode) voltage	V_{g4}	60 to 85 V	3
Grid 2 and 5 voltage	$V_{g2,5}$	300 V	2, 4
Grid 1 voltage for picture cut-off (no blanking applied)	V_{g1}	-80 to -30 V	
Blanking voltage, peak to peak			
when applied to grid 1		75 V	
when applied to cathode		20 V	
Flux density of adjustable alignment coils or magnets		0 to 0,4 mT	

Performance

		min.	typ.	max.	
Dark current (at 25 °C)			5	10 nA	
Signal current, white light faceplate illumination 1 lx c.t. 2856 K	I_s	250	320	nA	
Signal current, near infrared illumination 1 lx, c.t. 2856 K infrared transmitting filter imposed (transmission curve, see Fig. 2)	I_s	50	80	nA	
Decay: residual signal current 60 ms after cessation of the illumination initial signal current 200 nA			10	15 %	
Limiting resolution					
at picture centre		500	550	TV lines	5
at corner of picture		400	450	TV lines	5
Average γ of transfer characteristic, see Fig. 3			≈ 1		
Spurious signals (spots and blemishes)					6

Notes

1. The signal electrode voltage should be adjusted to the value indicated by the tube manufacturer as printed on the envelope ($E_{sj} = \dots V$). To minimize picture sticking effects the signal electrode should be adjusted within a tolerance of $\pm 2 V$; the voltage drop across R_1 should be kept small. In the case of cathode blanking the voltage drop across the cathode resistor during read-out should be taken into account.
2. Grids 3 + 6 voltage must always be higher than grids 2 + 5 voltage.
The recommended ratio of grids 3 + 6 voltage to grids 2 + 5 voltage for best geometry and most uniform signal output depends upon the type of coil used and will be 5 : 3 for the recommended types (see "Accessories").
3. Adjusted for correct electrical focus. This voltage range is higher than that of unipotential electrostatic focus, such as XQ1275.
4. Grids 2 + 5 voltage should be $> 250 V$ to provide sufficient beam current.
5. On EIA resolution test chart: faceplate illumination adjusted for a peak output current of 200 nA. The resolution is highly dependent on the coil used; the indicated figures are only valid for the recommended coil.

6. Conditions

The camera focused on a uniformly illuminated two-zone test pattern, the diameter of the centre zone (1) being equal to the raster height. Zone (2) being defined as the remainder of the scanned area.

Faceplate illumination adjusted to produce 200 nA signal current, beam current adjusted for correct stabilization.

Monitor set-up and contrast control adjusted for faint raster when lens of camera is capped and for non-blooming bright raster when lens of camera is uncapped.

Under above conditions the number and size of spots per zone visible in the monitor picture will not exceed the limits stated below. Both black and white spots must be counted, unless their contrast is less than 50% of peak white signal as observed on a waveform oscilloscope. Spots having a contrast $\geq 100\%$ are fully counted, spots having a contrast $> 50\%$ but $< 100\%$ will be considered as having half their actual size.

Spot size in % of raster height	Maximum number of spots	
	zone 1	zone 2
$> 1,2$	none	none
$\leq 1,2$ to 0,8	none	1
$\leq 0,8$ to 0,4	4	5
$\leq 0,4$ to 0,2	5	5
$\leq 0,2$	*	*
total (max.)	5	7

- * Do not count spots of this size unless concentration causes a smudgy appearance.
Tubes are rejected for: smudges, lines, streaks, mottled, grainy or uneven background having contrast $> 50\%$.

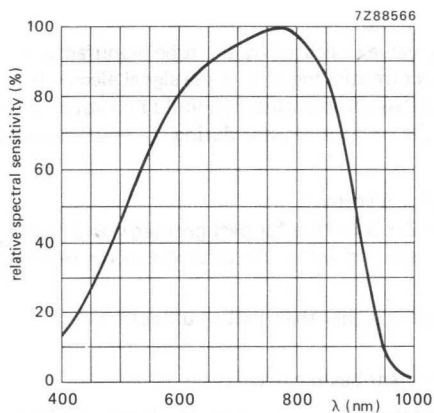

Fig. 1 Typical spectral response curve.

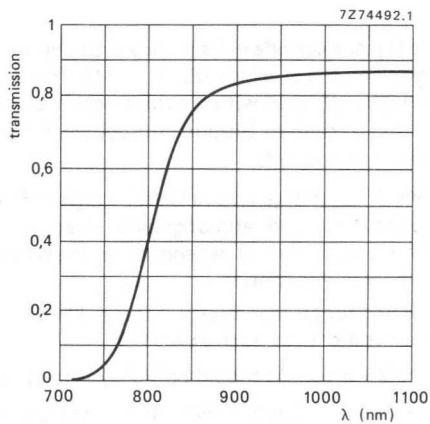

Fig. 2 Transmission curve of infrared filter.

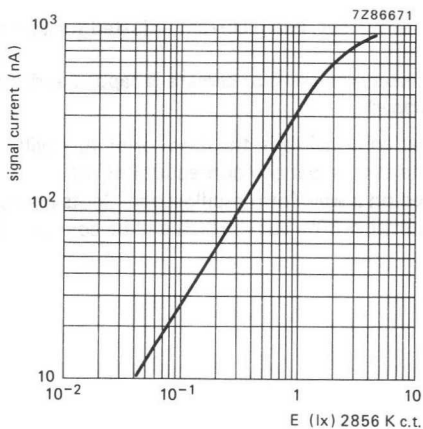

Fig. 3 Typical light transfer characteristic.

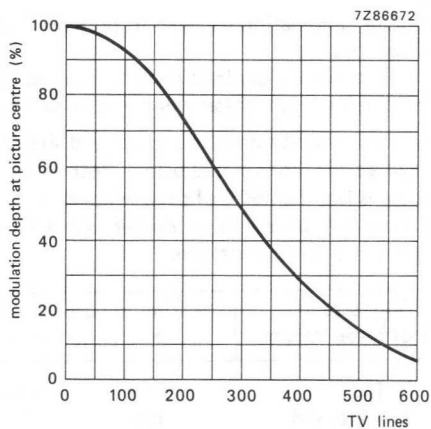

Fig. 4 Typical uncompensated square wave response curve. Highlight signal current 200 nA; beam current 200 nA. Focusing electrostatic and magnetic combined.

CAMERA TUBE

NEVVICON[®] television camera tube with a photoconductive target composed of cadmium and zinc tellurides featuring high resolution and an extremely high sensitivity.

The XQ1278 is a 2/3 in diameter camera tube with low heater power, separate mesh, electrostatic focusing and magnetic deflection and is mechanically interchangeable with vidicons such as XQ1272, XQ1590 and newvicons XQ1275. Pin configuration is similar.

The XQ1278 is intended for use in ultra-compact cameras for security and surveillance applications, for example, where its high sensitivity, small size and low power consumption are essential.

QUICK REFERENCE DATA

Separate mesh	
Focusing (bi-potential focusing lens)	electrostatic
Deflection	magnetic
Diameter	17,7 mm
Length	max. 108 mm
Spectral response, max. at	approx. 750 nm
cut-off at	approx. 900 nm
Heater	6,3 V, 95 mA
Limiting resolution	550 TV lines

OPTICAL

Diagonal of quality rectangle on photoconductive layer
(aspect ratio 3 : 4)

11 mm

Orientation of image on photoconductive layer:

The direction of the horizontal scan should be essentially parallel to the plane passing through the longitudinal tube axis and pin 4.

Face plate

thickness

1,5 mm

refractive index

1,61

Spectral response, curve see Fig. 1

HEATING Indirect by a.c. or d.c.; parallel or series supply

Heater voltage

V_f 6,3 V \pm 10%

Heater current at $V_f = 6,3$ V

I_f 95 mA

When the tube is used in a series heater chain, the heater voltage must not exceed an r.m.s. value of 9,5 V when the supply is switched on.

[®] Registered trade mark for television camera tubes.

CAPACITANCES

Signal electrode to all

$C_{as} \approx 2 \text{ pF}$

This capacitance, which is effectively the output impedance of the tube increases when the tube is inserted into the deflection unit.

MECHANICAL DATA

Dimensions in mm

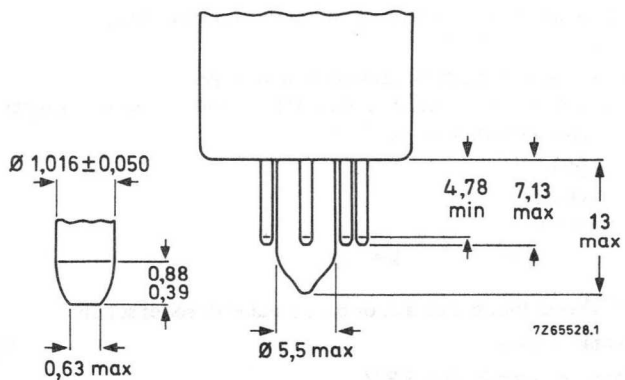
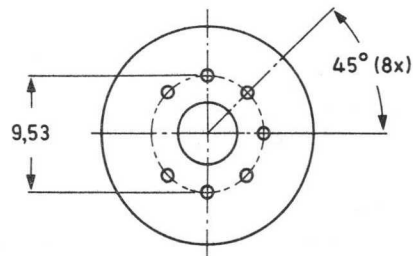
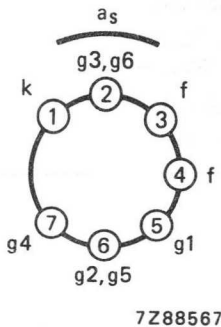
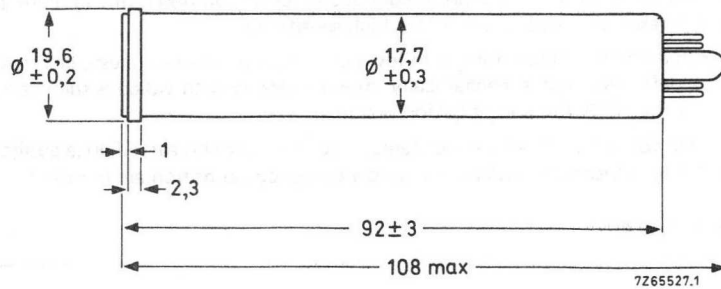

Mounting position: any

Net mass: $\approx 25 \text{ g}$

Base: JEDEC no. E7-91

ACCESSORIES

Socket	special miniature 7-pin, type 56049 or equivalent
Deflection coil unit	KV19G or equivalent

DEFLECTION

magnetic

FOCUSING

electrostatic (bipotential focusing
electron optics)

LIMITING VALUES (Absolute maximum rating system)

for a scanned area of 6,6 mm x 8,8 mm.

"Full-size scanning" i.e. scanning of a 6,6 mm x 8,8 mm area of the photoconductive layer should always be applied. Underscanning, i.e. scanning of an area smaller than 6,6 mm x 8,8 mm, may cause permanent damage to the specified full-size area.

Signal electrode voltage	V_{as}	max.	50 V*
Grid 3 and 6 voltage	$V_{g3,6}$	max.	750 V
Grid 4 voltage	V_{g4}	max.	350 V
Grid 2 and 5 voltage	$V_{g2,5}$	max.	350 V
Grid 1 voltage, negative	$-V_{g1}$	max.	300 V
	V_{g1}	max.	0 V
Cathode-to-heater voltage, peak positive	V_{kfp}	max.	125 V
	$-V_{kfp}$	max.	10 V
Output current, peak	I_{asp}	max.	800 nA**
Faceplate illumination	E	max.	10 000 lx [▲]
Faceplate temperature, storage and operation	T	max.	70 °C
Cathode heating time before drawing cathode current	t_h	min.	1 min

* Newvicon tubes do not permit automatic sensitivity control by means of regulation of the signal electrode voltage. Adequate control is therefore to be achieved by other means (iris control and neutral density filters). If the tube is applied in cameras originally designed for vidicon tubes, the automatic sensitivity control circuitry should be made inoperative and the signal electrode voltage set to the value indicated on the tube. See General Operational Notes.

** Video amplifiers should be capable of handling signal electrode currents of this magnitude without overloading the amplifier or distorting the picture.

▲ White light, uniformly diffused over entire tube face.

Care must be taken not to focus the solar image on the target through a lens opening wider than $f : 11$ to avoid instantaneous breakdown.

OPERATING CONDITIONS AND PERFORMANCE

for a scanned area of 6,6 mm x 8,8 mm, a faceplate temperature of 25 to 35 °C
and standard TV scanning rate.

Conditions			notes
Signal electrode voltage	V_{as}	10 to 35 V	1
Grid 3 and 6 (decelerator) voltage	$V_{g3,6}$	500 V	2
Grid 4 (beam focus electrode) voltage	V_{g4}	60 to 85 V	3
Grid 2 and 5 voltage	$V_{g2,5}$	300 V	2, 4
Grid 1 voltage for picture cut-off (no blanking applied)	V_{g1}	-80 to -30 V	
Blanking voltage, peak to peak		75 V	
when applied to grid 1		20 V	
when applied to cathode			
Flux density of adjustable alignment coil or magnet		0 to 0,4 mT	

Performance

	min.	typ.	max.	
Dark current (at 25 °C)		2	4 nA	
Signal current, white light faceplate illumination 1 lx c.t. 2856 K	I_s 200	260	nA	
Decay: residual signal current 60 ms after cessation of the illumination initial signal current 200 nA		10	15 %	
Limiting resolution, at picture centre	500	550	TV lines	5
at corner of picture	400	450	TV lines	5
Average γ of transfer characteristic, see Fig. 2		≈ 1		
Spurious signals (spots and blemishes)				6

Notes

1. The signal electrode voltage should be adjusted to the value indicated by the tube manufacturer as printed on the envelope ($E_{sj} = \dots V$). To minimize picture sticking effects the signal electrode should be adjusted within a tolerance of $\pm 2 V$; the voltage drop across R_1 should be kept small. In the case of cathode blanking the voltage drop across the cathode resistor during read-out should be taken into account.
2. Grids 3 + 6 voltage must always be higher than grids 2 + 5 voltage.
The recommended ratio of grids 3 + 6 voltage to grids 2 + 5 voltage for best geometry and most uniform signal output depends upon the type of coil used and will be 5 : 3 for the recommended types (see "Accessories").
3. Adjusted for correct electrical focus. This voltage range is higher than that of unipotential electrostatic focus, such as XQ1275.
4. Grids 2 + 5 voltage should be $> 250 V$ to provide sufficient beam current.
5. On EIA resolution test chart: faceplate illumination adjusted for a peak output current of 200 nA. The resolution is highly dependent on the coil used; the indicated figures are only valid for the recommended coil.

6. Conditions

The camera focused on a uniformly illuminated two-zone test pattern, the diameter of the centre zone (1) being equal to the raster height. Zone (2) being defined as the remainder of the scanned area.

Faceplate illumination adjusted to produce 200 nA signal current, beam current adjusted for correct stabilization.

Monitor set-up and contrast control adjusted for faint raster when lens of camera is capped and for non-blooming bright raster when lens of camera is uncapped.

Under above conditions the number and size of spots per zone visible in the monitor picture will not exceed the limits stated below. Both black and white spots must be counted, unless their contrast is less than 50% of peak white signal as observed on a waveform oscilloscope. Spots having a contrast $\geq 100\%$ are fully counted, spots having a contrast $> 50\%$ but $< 100\%$ will be considered as having half their actual size.

Spot size in % of raster height	Maximum number of spots	
	zone 1	zone 2
$> 1,2$	none	none
$\leq 1,0$ to $0,8$	none	1
$\leq 0,8$ to $0,4$	4	4
$\leq 0,4$ to $0,2$	4	4
$\leq 0,2$	*	*
total (max.)	8	

* Do not count spots of this size unless concentration causes a smudgy appearance.

Tubes are rejected for: smudges, lines, streaks, mottled, grainy or uneven background having contrast $> 50\%$.

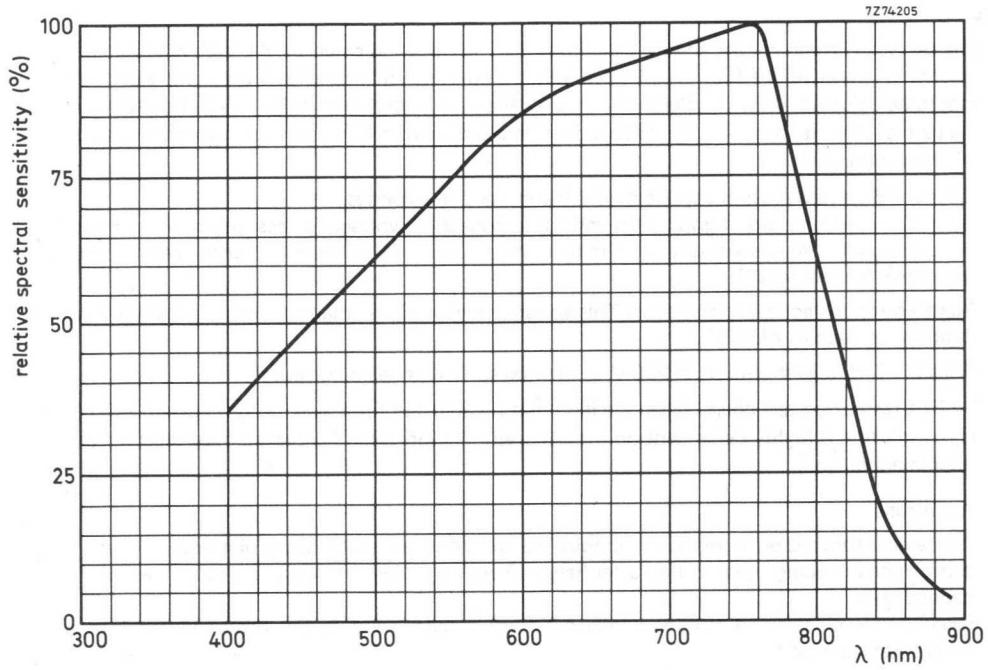

Fig. 1 Typical spectral response curve.

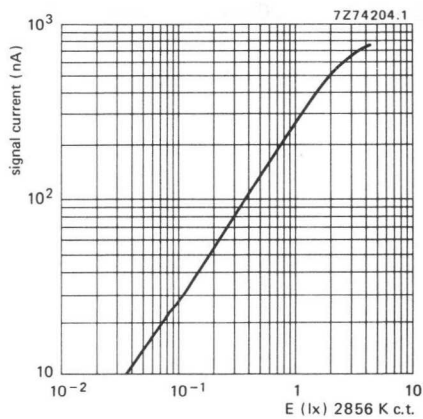

Fig. 2 Typical light transfer characteristic.

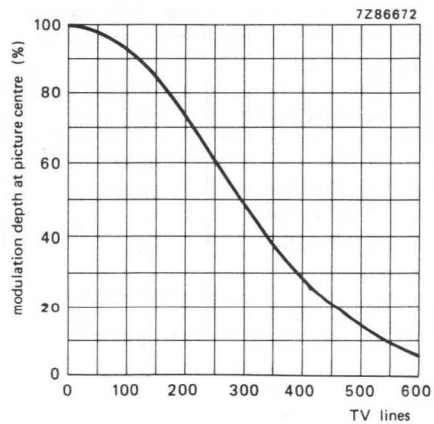

Fig. 3 Typical uncompensated square wave response curve. Highlight signal current 200 nA; beam current 200 nA. Focusing electrostatic and magnetic combined.

CAMERA TUBE

Newvicon® camera tube, mechanically and electron-optically identical to the XQ1274, the major difference being the radiation resistant (anti-browning) faceplate.

The XQ1380 is intended for use in compact cameras which are subjected to high doses of ionizing radiation.

RADIATION RESISTANT FACEPLATE

The faceplate of the XQ1380 is made of a special type of glass and does not turn brown under the influence of high doses of gamma radiation.

- Maximum dose rate per hour: 5×10^5 Röntgen/hour
- Maximum cumulative dose: 5×10^7 Röntgen
- Maximum decrease of transmission of faceplate:

Maximum decrease	After a cumulative dose of
3%	10^5 Röntgen
10%	10^6 Röntgen
15%	5×10^7 Röntgen

- Maximum increase of dark current at 25 °C after a cumulative dose of 5×10^7 Röntgen: 75%

SENSITIVITY

The typical sensitivity of the XQ1380 is approximately 10% less than for the XQ1274.

For all other information see data of XQ1274.

CAMERA TUBE

Newvicon® camera tube, mechanically and electron-optically identical to the XQ1275, the major difference being the radiation resistant (anti-browning) faceplate.

The XQ1381 is intended for use in compact cameras which are subjected to high doses of ionizing radiation.

RADIATION RESISTANT FACEPLATE

The faceplate of the XQ1381 is made of a special type of glass and does not turn brown under the influence of high doses of gamma radiation.

- Maximum dose rate per hour: 5×10^5 Röntgen/hour
- Maximum cumulative dose: 5×10^7 Röntgen
- Maximum decrease of transmission of faceplate:

Maximum decrease	After a cumulative dose of
3%	10^5 Röntgen
10%	10^6 Röntgen
15%	5×10^7 Röntgen
- Maximum increase of dark current at 25 °C after a cumulative dose of 5×10^7 Röntgen: 75%

SENSITIVITY

The typical sensitivity of the XQ1381 is approximately 10% less than for the XQ1275.

For all other information see data of XQ1275.

CAMERA TUBE

NEWVICON® television camera tube with a photoconductive target composed of cadmium and zinc tellurides featuring high resolution and an extremely high sensitivity.

The XQ1440 is a 1 in diameter camera tube with low heater power, separate mesh, magnetic focusing and deflection, and is mechanically interchangeable with vidicons like the XQ1240 and has the same pin connections.

The XQ1440 is intended for use in cameras for security and surveillance applications, for example, where its high sensitivity and resolution are essential.

QUICK REFERENCE DATA

Separate mesh			
Focusing		magnetic	
Deflection		magnetic	
Diameter		25,9	mm
Length		159	mm
Spectral response, max. at cut-off at	approx.	750	nm
	approx.	900	nm
Heater		6,3 V, 95	mA
Limiting resolution		750	TV lines

OPTICAL

Diagonal of quality rectangle on photoconductive layer (aspect ratio 3 : 4) 16 mm

Orientation of image on photoconductive layer:

The direction of the horizontal scan should be essentially parallel to the plane passing through the longitudinal tube axis and the short index pin.

Spectral response curve see Fig. 1

Faceplate	
thickness	2,5 mm
refractive index	1,61

HEATING

Indirect by a.c. or d.c.; parallel or series supply

Heater voltage	V_f	6,3 V \pm 10%
----------------	-------	-----------------

Heater current, at $V_f = 6,3$ V	I_f	95 mA
----------------------------------	-------	-------

When the tube is used in a series heater chain, the heater voltage must not exceed an r.m.s. value of 9,5 V when the supply is switched on.

XQ1440

CAPACITANCES

Signal electrode to all

$$C_{as} \approx 4,6 \text{ pF}$$

This capacitance, which is effectively the output impedance of the tube, increases when the tube is inserted into the deflection and focusing coil unit.

MECHANICAL DATA

Dimensions in mm

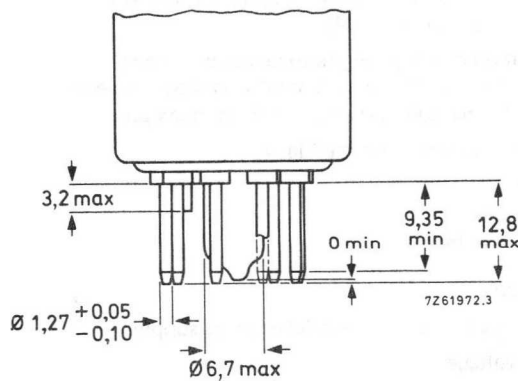
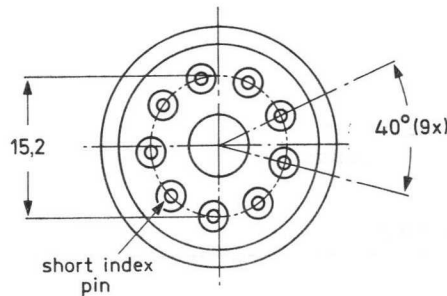
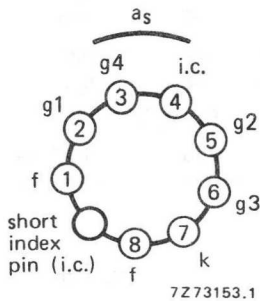
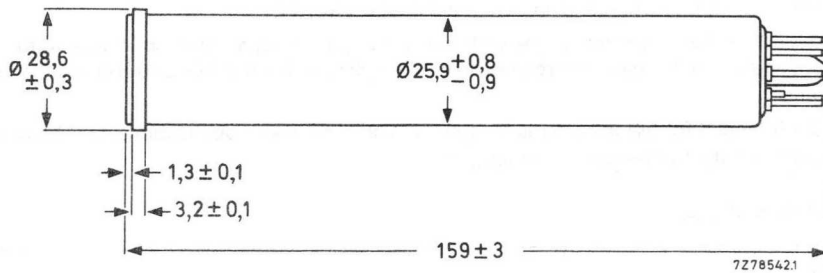

Base: JEDEC no. E8-11
 Mounting position: any
 Net mass: ≈ 62 g

ACCESSORIES

Socket	56098 or equivalent
Deflection and focusing coil unit	KV9G or equivalent

DEFLECTION

magnetic

FOCUSING

magnetic

LIMITING VALUES (Absolute maximum rating system)
for a scanned area of 9,6 mm x 12,8 mm.

"Full-size scanning" i.e. scanning of a 9,6 mm x 12,8 mm area of the photoconductive layer should always be applied. Underscanning, i.e. scanning of an area smaller than 9,6 mm x 12,8 mm, may cause permanent damage to the specified full-size area.

Signal electrode voltage	V_{as}	max.	50 V *
Grid 4 voltage	V_{g4}	max.	1000 V
Grid 3 voltage	V_{g1}	max.	1000 V
Grid 2 voltage	V_{g2}	max.	750 V
Grid 1 voltage, negative	$-V_{g1}$	max.	300 V
positive	V_{g1}	max.	0 V
Cathode-to-heater voltage, peak positive	V_{kfp}	max.	125 V
peak negative	$-V_{kfp}$	max.	10 V
Output current, peak	I_{asp}	max.	800 nA**
Faceplate illumination	E	max.	10 000 lx [▲]
Faceplate temperature, storage and operation	T	max.	70 °C
Cathode heating time before drawing cathode current	t_h	min.	1 min

* Newwicon tubes do not permit automatic sensitivity control by means of regulation of the signal electrode voltage. Adequate control is therefore to be achieved by other means (iris control and neutral density filters). If the tube is applied in cameras originally designed for vidicon tubes, the automatic sensitivity control circuitry should be made inoperative and the signal electrode voltage set to the value indicated by the tube manufacturer. See General Operational Notes.

** Video amplifiers should be capable of handling signal electrode currents of this magnitude without overloading the amplifier or distorting the picture.

▲ White light, uniformly diffused over entire tube face.

Care must be taken not to focus the solar image on the target through a lens opening wider than $f : 11$ to avoid instantaneous breakdown.

OPERATING CONDITIONS AND PERFORMANCE

for a scanned area of 9,6 mm x 12,8 mm, a faceplate temperature of 25 to 35 °C and standard TV scanning rate.

Conditions

			notes
Signal electrode voltage	V_{as}	10 to 35 V	1
Grid 4 (decelerator) voltage	V_{g4}	500 V	2
Grid 3 (beam focus electrode) voltage	V_{g3}	300 V	3
Grid 2 (accelerator) voltage	V_{g2}	300 V	
Grid 1 voltage for picture cut-off (no blanking applied)	V_{g1}	-100 to -45 V	
Blanking voltage, peak to peak			
when applied to grid 1		75 V	
when applied to cathode		20 V	
Flux density at centre of focusing coil		3,8 to 4,4 mT	
Flux density of adjustable alignment coil or magnet		0 to 0,4 mT	

Performance

	min.	typ.	max.
Dark current (at 25 °C)		3,5	7 nA
Signal current, white light faceplate illumination 0,5 lx c.t. 2856 K	I_s 200	240	nA
Decay: residual signal current 60 ms after cessation of the illumination (c.t. 2856 K), initial signal current 200 nA		17	25%
Limiting resolution, at picture centre	650	750	TV lines 4
at picture corners	400	500	TV lines 4
Average γ of transfer characteristic		≈ 1	
Spurious signals (spots and blemishes)			5

Notes

1. The signal electrode voltage should be adjusted to the value indicated by the tube manufacturer as printed on the envelope ($E_{sj} = \dots V$).
To minimize picture sticking effects the signal electrode voltage should be adjusted within a tolerance of $\pm 2 V$; the voltage drop across R_1 should be kept small. In the case of cathode blanking the voltage drop across the cathode resistor during read-out should be taken into account.
2. Grid 4 voltage must always be higher than grid 3 voltage. The recommended ratio of grid 4 voltage to grid 3 voltage both for best geometry and most uniform signal output depends upon the type of coil unit used and will be 5 : 3 for the recommended type (see "Accessories").
3. Resolution decreases with decreasing grid 3 voltage. In general grid 3 should be operated above 250 V.
4. On EIA resolution test chart: faceplate illumination adjusted for a peak output current of 200 nA.

5. Conditions

The camera focused on a uniformly illuminated two-zone test pattern, the diameter of the centre zone (1) being equal to the raster height. Zone (2) being defined as the remainder of the scanned area. Faceplate illumination adjusted to produce 200 nA signal current, beam current adjusted for correct stabilization.

Monitor set-up and contrast control adjusted for faint raster when lens of camera is capped and for non-blooming bright raster when lens of camera is uncapped.

Under above conditions the number and size of spots per zone visible in the monitor picture will not exceed the limits stated below. Both black and white spots must be counted, unless their contrast is less than 50% of peak white signal as observed on a waveform oscilloscope. Spots having a contrast $\geq 100\%$ are fully counted, spots having a contrast $> 50\%$ but $< 100\%$ will be considered as having half their actual size.

Spot size in % of raster height	Maximum number of spots	
	zone 1	zone 2
$> 1,2$	none	none
$\leq 1,0$ to 0,8	none	1
$\leq 0,8$ to 0,4	4	4
$\leq 0,4$ to 0,2	4	4
$\leq 0,2$	*	*
total (max.)	8	

* Do not count spots of this size unless concentration causes a smudgy appearance.

Tubes are rejected for: smudges, lines, streaks, mottled, grainy or uneven background having contrast $> 50\%$.

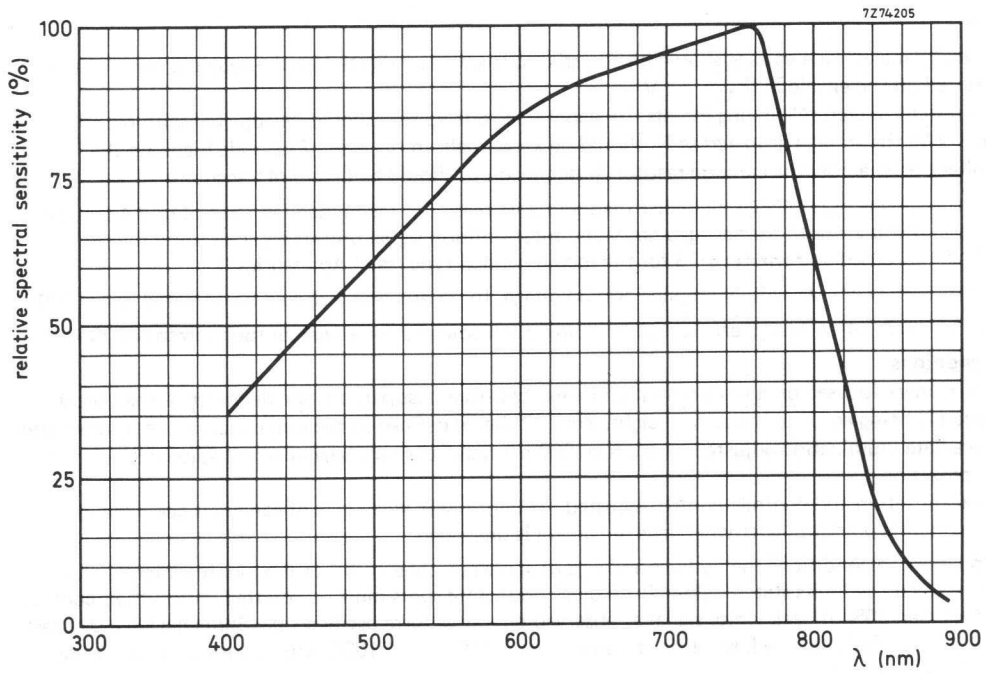

Fig. 1 Typical spectral response curve.

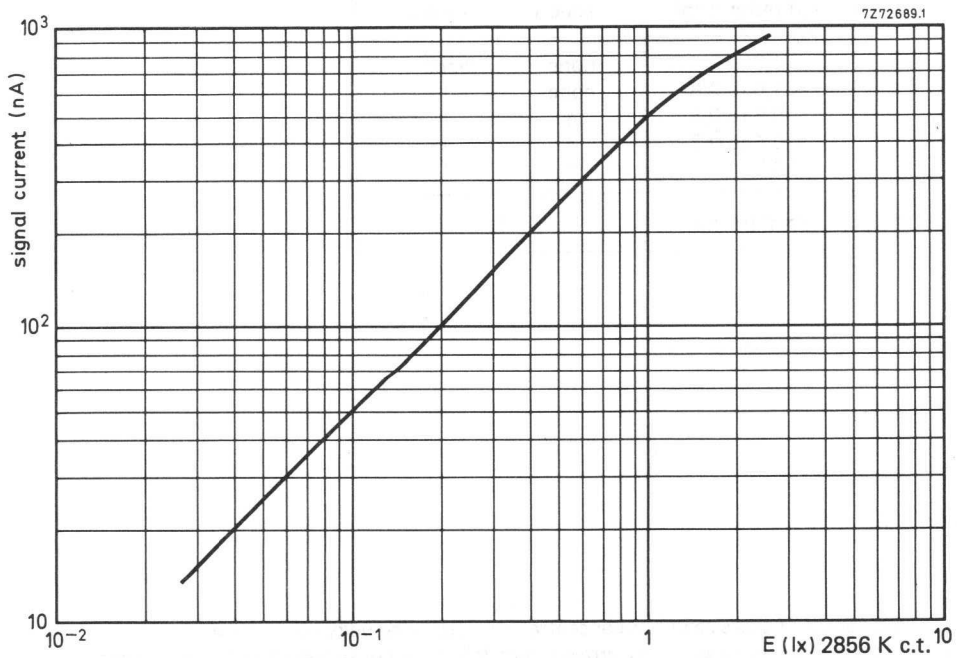

Fig. 2 Typical light transfer characteristic.

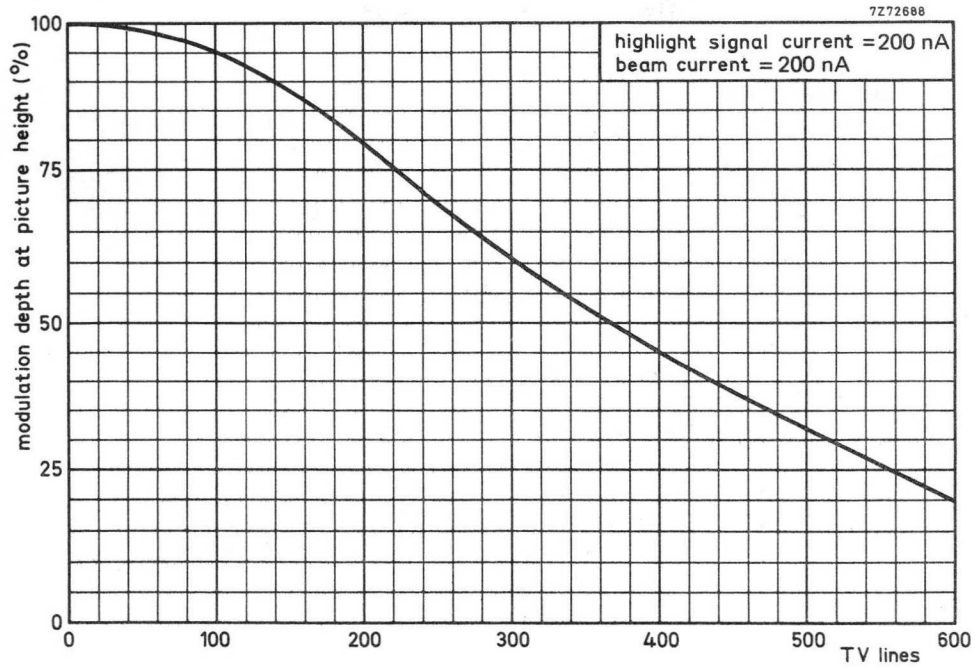

Fig. 3 Typical uncompensated square wave response curve.

CAMERA TUBE

NEWVICON[®] television camera tube with a photoconductive target composed of cadmium and zinc tellurides featuring high resolution and an extremely high sensitivity.

The XQ1442 is a 1 in diameter camera tube with low heater power, separate mesh, magnetic focusing and deflection, a fibre optic faceplate, and is mechanically and electrically interchangeable with the Newvicon tube type XQ1440.

The XQ1442 is intended for use in low light level cameras, in which it is coupled directly to a fibre optic output window of an image intensifier, for scientific, industrial, surveillance and security applications.

QUICK REFERENCE DATA

Separate mesh		
Focusing		magnetic
Deflection		magnetic
Diameter		25,9 mm
Length		159 mm
Faceplate		fibre optic
Spectral response, max. at	approx.	750 nm
cut-off at	approx.	900 nm
Heater		6,3 V, 95 mA
Limiting resolution		650 TV lines

OPTICAL

Diagonal of quality rectangle on photoconductive layer (aspect ratio 3 : 4) 16 mm

Orientation of image on photoconductive layer

The direction of the horizontal scan should be essentially parallel to the plane passing through the longitudinal tube axis and the short index pin.

Spectral response curve see Fig. 1

Faceplate thickness	3,0 mm
refractive index	1,00

HEATING

Indirect by a.c. or d.c. parallel or series supply

Heater voltage	V_f	6,3 V \pm 10%
Heater current, at $V_f = 6,3$ V	I_f	95 mA

When the tube is used in a series heater chain, the heater voltage must not exceed an r.m.s. value of 9,5 V when the supply is switched on.

[®]Registered trade mark for television camera tubes.

CAPACITANCES

Signal electrode to all

$$C_{as} \approx 4,6 \text{ pF}$$

This capacitance, which is effectively the output impedance of the tube, increases when the tube is inserted into the deflection and focusing coil unit.

MECHANICAL DATA

Dimensions in mm

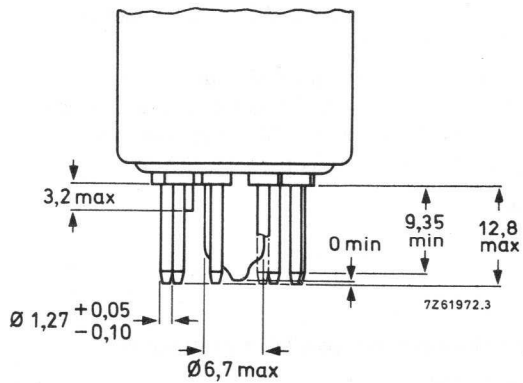
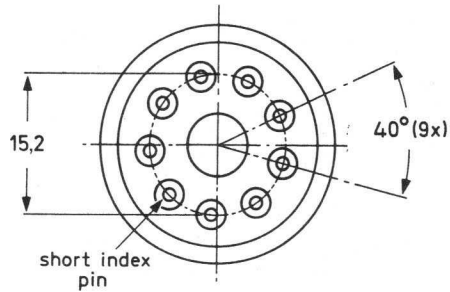
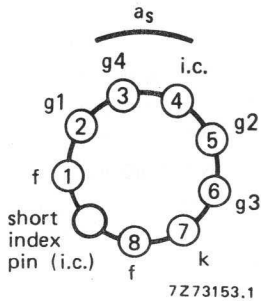
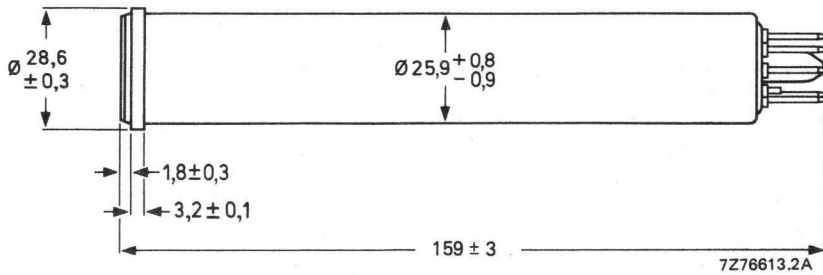

Base: JEDEC no. E8-11

Mounting position: any

Net mass: $\approx 62 \text{ g}$

ACCESSORIES

Socket	56098 or equivalent
Deflection and focusing coil unit	KV9G or equivalent

DEFLECTION

magnetic

FOCUSING

magnetic

LIMITING VALUES (Absolute maximum rating system)
for a scanned area of 9,6 mm x 12,8 mm.

'Full-size scanning' i.e. scanning of a 9,6 mm x 12,8 mm area of the photoconductive layer should always be applied. Underscanning i.e. scanning of an area smaller than 9,6 mm x 12,8 mm, may cause permanent damage to the specified full-size area.

Signal electrode voltage	V_{as}	max	50 V*
Grid 4 voltage	V_{g4}	max	1000 V
Grid 3 voltage	V_{g3}	max	1000 V
Grid 2 voltage	V_{g2}	max	750 V
Grid 1 voltage, negative	$-V_{g1}$	max	300 V
positive	V_{g1}	max	0 V
Cathode-to-heater voltage, peak positive	V_{kfp}	max	125 V
peak negative	$-V_{kfp}$	max	10 V
Output current, peak	I_{asp}	max	800 nA**
Faceplate illumination	E	max	10 000 lx [▲]
Faceplate temperature, storage and operation	T	max	70 °C
Cathode heating time before drawing cathode current	t_h	min	1 min

* Newwicon tubes do not permit automatic sensitivity control by means of regulation of the signal electrode voltage. Adequate control is therefore to be achieved by other means (iris control and neutral density filters). If the tube is applied in cameras originally designed for vidicon tubes, the automatic sensitivity control circuitry should be made inoperative and the signal electrode voltage set to the value indicated by the tube manufacturer. See General Operational Notes.

** Video amplifiers should be capable of handling signal electrode currents of this magnitude without overloading the amplifier or distorting the picture.

▲ White light, uniformly diffused over entire tube face. Care must be taken not to focus the solar image on the target through a lens opening wider than $f:11$ to avoid instantaneous breakdown.

OPERATING CONDITIONS AND PERFORMANCE

for a scanned area of 9,6 mm x 12,8 mm, a faceplate temperature of 25 to 35 °C and standard TV scanning rate.

Conditions

			notes
Signal electrode voltage	V_{as}	10 to 25 V	1
Grid 4 (decelerator) voltage	V_{g4}	500 V	2
Grid 3 (beam focus electrode) voltage	V_{g3}	300 V	3
Grid 2 (accelerator) voltage	V_{g2}	300 V	
Grid 1 voltage picture cut-off (no blanking applied)	V_{g1}	-100 to -45 V	
Blanking voltage, peak to peak			
when applied to grid 1		75 V	
when applied to cathode		20 V	
Flux density at centre of focusing coil		3,8 to 4,4 mT	
Flux density of adjustable alignment coil or magnet		0 to 0,4 mT	

Performance

	min.	typ.	max.	
Dark current (at 25 °C)		7	16	nA
Signal current, white light faceplate illuminance 0,5 lx, c.t. 2856 K	I_s 140	180		nA
Decay: residual signal current 60 ms after cessation of the illumination (c.t. 2856 K), initial signal current 200 nA		17	22	%
Limiting resolution, at picture centre	550	650		TV lines 4
at picture corners		450		TV lines 4
Average γ of transfer characteristic		≈ 1		
Spurious signals (spots and blemishes)				5

Notes

1. The signal electrode voltage should be adjusted to the value indicated by the tube manufacturer as printed on the envelope ($E_{sj} = \dots V$).
To minimize picture sticking effects the signal electrode voltage should be adjusted within a tolerance acy of $\pm 2 V$, the voltage drop across R_1 should be kept small. In the case of cathode blanking, the voltage drop across the cathode resistor during read-out should be taken into account.
2. Grid 4 voltage must always be higher than grid 3 voltage. The recommended ratio of grid 4 voltage to grid 3 voltage both for best geometry and most uniform signal output depends upon the type of coil unit used and will be 5 : 3 for the recommended types (see "Accessories").
3. Resolution decreases with decreasing grid 3 voltage. In general grid 3 should be operated above 250 V.
4. On EIA resolution test chart; faceplate illumination adjusted for a peak output current of 200 nA.

5. Conditions

The camera focused on a uniformly illuminated two-zone test pattern, the diameter of the centre zone (1) being equal to the raster height. Zone (2) being defined as the remainder of the scanned area.

Faceplate illumination adjusted to produce 200 nA signal current, beam current adjusted for correct stabilization.

Monitor set-up and contrast control adjusted for faint raster when lens of camera is capped and for non-blooming bright raster when lens of camera is uncapped.

Under the above conditions the number and size of spots per zone visible in the monitor picture, under both capped and uncapped conditions will not exceed the limits stated below. Both black and white spots must be counted unless their contrast is less than 10% of peak white signal as observed on a waveform oscilloscope.

Background lines, originating from the structure of the fibre optic faceplate will have a contrast of $\leq 25\%$ of peak white signal and will not exceed a width of 0,4%, or a length of 6% of picture height.

	spot size in % of raster height	maximum number of spots	
		zone 1	zone 2
white and black spots	$> 1,4$	none	none
	$\leq 1,4$ to 0,8	none	1
	$\leq 0,8$ to 0,6	2	3
white spots	$\leq 0,6$ to 0,2	4	6
	$\leq 0,2$	*	*
black spots	$\leq 0,6$ to 0,4	8	10
	$\leq 0,4$	*	*

* Do not count spots of this size unless concentration causes a smudgy appearance.

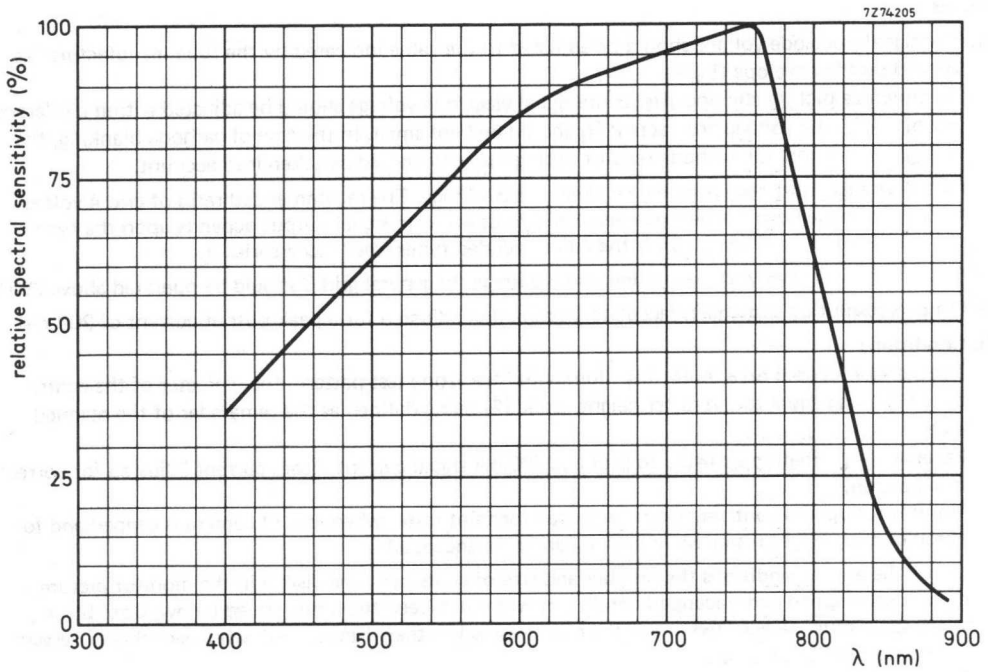

Fig.1 Typical spectral response curve.

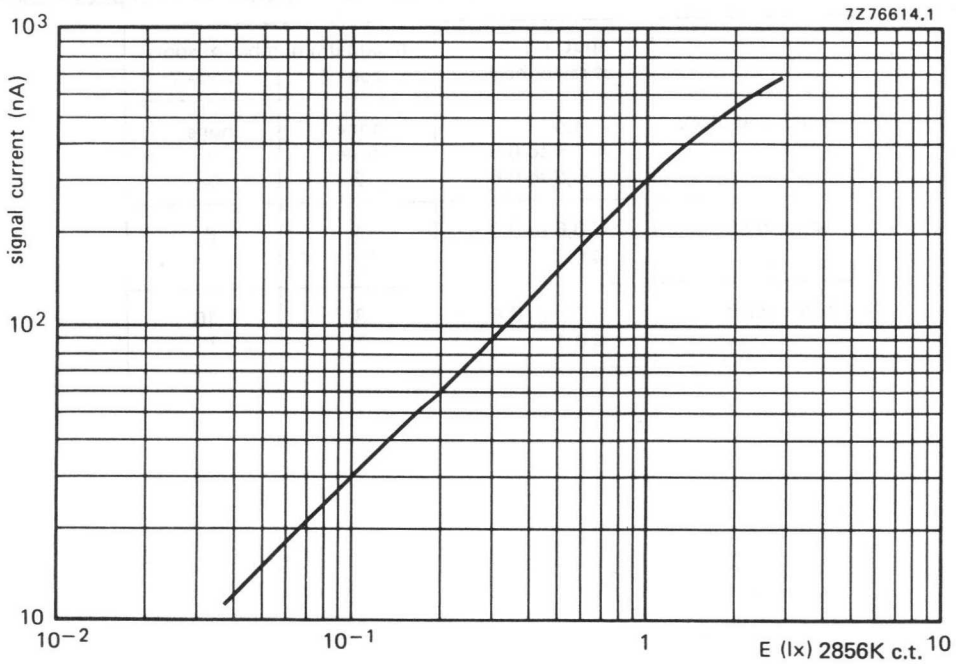

Fig.2 Typical light transfer characteristic.

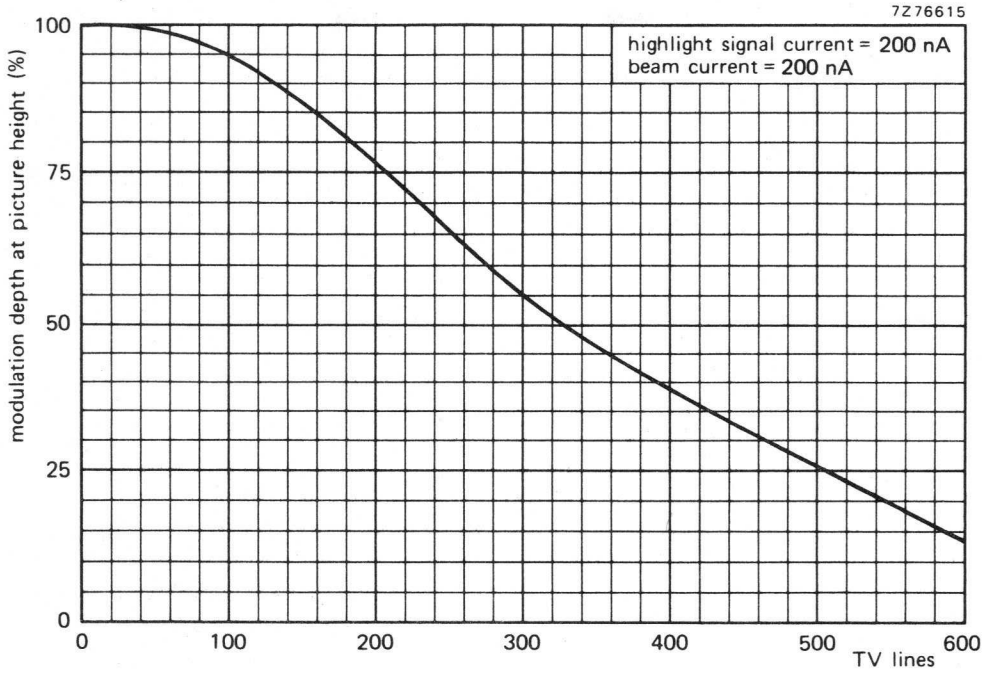

Fig.3 Typical uncompensated square-wave response curve.

CAMERA TUBE

NEWVICON® television camera tube with a photoconductive target composed of cadmium and zinc tellurides featuring high resolution and an extremely high sensitivity extending into the near infrared region.

The XQ1443 is a 1 in diameter camera tube with low heater power, separate mesh, magnetic focusing and deflection, and is mechanically interchangeable with vidicons like the XQ1240/XQ1241 and Newvicon tube XQ1440 and has the same pin connections.

The XQ1443 is intended for use in ultra-sensitive cameras for security and surveillance applications, for example, where its high sensitivity extending into the near infrared, and its high resolution, small size and low power consumption are essential.

QUICK REFERENCE DATA

Separate mesh	
Focusing	magnetic
Deflection	magnetic
Diameter	25,9 mm
Length	159 mm
Spectral response, max. at	approx. 775 nm
Spectral response, cut-off at	approx. 1000 nm
Heater	6,3 V, 95 mA
Limiting resolution	750 TV lines

OPTICAL

Diagonal of quality rectangle on photoconductive layer (aspect ratio 3 : 4)	16 mm
Orientation of image on photoconductive layer: The direction of the horizontal scan should be essentially parallel to the plane passing through the longitudinal tube axis and the short index pin.	
Faceplate thickness	2,5 mm
refractive index	1,61
Spectral response curve see Fig. 1	

HEATING

Indirect by a.c. or d.c.; parallel or series supply

Heater voltage	V_f	6,3 V \pm 10%
Heater current at $V_f = 6,3$ V	I_f	95 mA

When the tube is used in a series heater chain, the heater voltage must not exceed an r.m.s. value of 9,5 V when the supply is switched on.

® Registered trade mark for television camera tubes.

CAPACITANCES

Signal electrode to all

$$C_{as} \approx 4,6 \text{ pF}$$

This capacitance, which is effectively the output impedance of the tube, increases when the tube is inserted in the deflection and focusing coil unit.

MECHANICAL DATA

Dimensions in mm

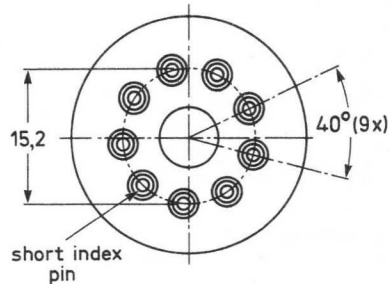
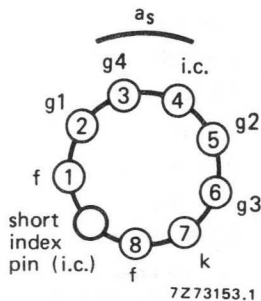
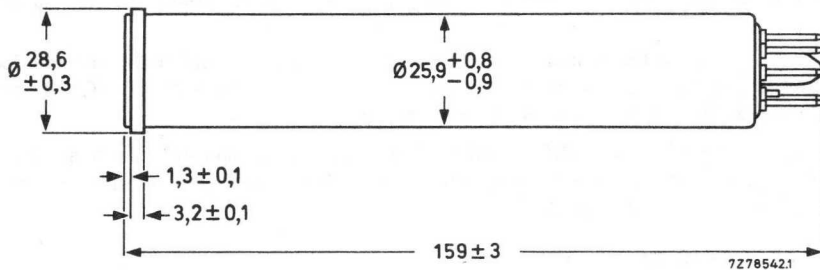

BASE PIN CONNECTIONS (Bottom view)

- Pin 1 heater
- Pin 2 grid 1
- Pin 3 grid 4
- Pin 4 i.c. (internally connected)
- Pin 5 grid 2
- Pin 6 grid 3
- Pin 7 cathode
- Pin 8 heater
- Short index pin i.c.
- Flange target (signal electrode)

Mounting position any

Net mass $\approx 70 \text{ g}$

Base JEDEC No. E8-11

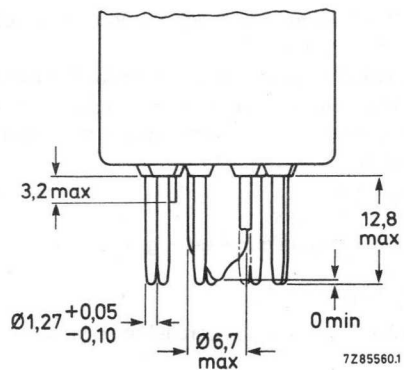

ACCESSORIES

Socket	type 56098 or equivalent
Deflection and focusing coil unit	KV9G or equivalent

DEFLECTION

magnetic

FOCUSING

magnetic

LIMITING VALUES (Absolute maximum rating system)
for a scanned area of 9,6 mm x 12,8 mm.

'Full-size scanning' i.e. scanning of a 9,6 mm x 12,8 mm area of the photoconductive layer should always be applied. Underscanning, i.e. scanning of an area smaller than 9,6 mm x 12,8 mm, may cause permanent damage to the specified full-size area.

Signal electrode voltage	V_{as}	max.	50 V *
Grid 4 voltage	V_{g4}	max.	1000 V
Grid 3 voltage	V_{g3}	max.	1000 V
Grid 2 voltage	V_{g2}	max.	750 V
Grid 1 voltage, negative	$-V_{g1}$	max.	300 V
Grid 1 voltage, positive	V_{g1}	max.	0 V
Cathode-to-heater voltage, peak positive	$V_{kf p}$	max.	125 V
Cathode-to-heater voltage, peak negative	$-V_{kf p}$	max.	10 V
Output current, peak	I_{asp}	max.	800 nA**
Faceplate illumination	E	max.	10 000 lx [▲]
Faceplate temperature, storage and operation	T	max.	60 °C
Cathode heating time before drawing cathode current	t_h	min.	1 min

* Newvicon tubes do not permit automatic sensitivity control by means of regulation of the signal electrode voltage. Adequate control is therefore to be achieved by other means (iris control and neutral density filters). If the tube is applied in cameras originally designed for vidicon tubes, the automatic sensitivity control circuitry should be made inoperative and the signal electrode voltage set to the value indicated by the tube manufacturer. See General Operational Notes.

** Video amplifiers should be capable of handling signal-electrode currents of this magnitude without overloading the amplifier or distorting the picture.

▲ White light, uniformly diffused over entire tube face.

Care must be taken not to focus the solar image on the target through a lens opening wider than $f : 11$ to avoid instantaneous breakdown.

OPERATING CONDITIONS AND PERFORMANCE

for a scanned area of 9,6 mm x 12,8 mm and a faceplate temperature of 25 to 35 °C and standard TV scanning rate.

Conditions				notes
Signal electrode voltage	V_{as}	10 to 25 V		1
Grid 4 (decelerator) voltage	V_{g4}	500 V		2
Grid 3 (beam focus electrode) voltage	V_{g3}	300 V		3
Grid 2 (accelerator) voltage	V_{g2}	300 V		
Grid 1 voltage for picture cut-off (no blanking applied)	V_{g1}	-100 to -45 V		
Blanking voltage, peak to peak				
when applied to grid 1			75 V	
when applied to cathode			25 V	
Flux density at centre of focusing coil			3,8 to 4,4 mT	
Flux density of adjustable alignment coil or magnet			0 to 0,4 mT	
Performance		min.	typ.	max.
Dark current (at 25 °C)			8	15 nA
Signal current, white light faceplate illumination 0,5 lx c.t. 2856 K	I_s	240	270	nA
Signal current, near infrared illumination 0,5 lx, c.t. 2856 K infrared transmitting filter interposed (transmission curve see Fig. 2)	I_s	50	75	nA
Decay: residual signal current 60 ms after cessation of the illumination (c.t. 2856 K) initial signal current 200 nA			17	%
Limiting resolution, at picture centre		650	750	TV lines 4
Limiting resolution, at picture corners		400	500	TV lines 4
Average γ of transfer characteristic			≈ 1	
Spurious signals (spots and blemishes)				5

Notes

1. The signal electrode voltage should be adjusted to the value indicated by the tube manufacturer as printed on the envelope ($E_{sj} = \dots V$).
To minimize picture sticking effects the signal electrode voltage should be adjusted within a tolerance of $\pm 2 V$; the voltage drop across R_1 should be kept small. In case of cathode blanking the voltage drop across the cathode resistor during read-out should be taken into account.
2. Grid 4 voltage must always be higher than grid 3 voltage. The recommended ratio of grid 4 voltage to grid 3 voltage both for best geometry and most uniform signal output depends upon the type of coil unit used and will be 5 : 3 for the recommended type (see 'Accessories').
3. Resolution decreases with decreasing grid 4 voltage. In general grid 3 should be operated above 250 V.
4. On EIA resolution test chart; faceplate illumination adjusted for a peak output current of 200 nA.

5. Conditions

The camera focused on a uniformly illuminated two-zone test pattern, the diameter of the centre zone (1) being equal to the raster height. Zone (2) being defined as the remainder of the scanned area.

Faceplate illumination adjusted to produce 200 nA signal current, beam current adjusted for correct stabilization.

Monitor set-up and contrast control adjusted for faint raster when lens of camera is capped and for non-blooming bright raster when lens of camera is uncapped.

Under above conditions the number and size of spots per zone as visible in the monitor picture will not exceed the limits stated below. Both black and white spots must be counted, unless their contrast is less than 50% of peak white signal as observed on a waveform oscilloscope. Spots having a contrast $\geq 100\%$ are fully counted, spots having a contrast $> 50\%$ but $< 100\%$ will be considered as having half their actual size.

spot size in % of raster height	maximum number of spots	
	zone 1	zone 2
$> 1,2$	none	none
$\leq 1,2$ to 0,8	none	1
$\leq 0,8$ to 0,4	4	5
$\leq 0,4$ to 0,2	5	5
$\leq 0,2$	*	*
total (max.)	5	7

* Do not count spots of this size unless concentration causes a smudgy appearance.
Tubes are rejected for: smudges, lines, streaks, mottled, grainy or uneven background having contrast $> 50\%$.

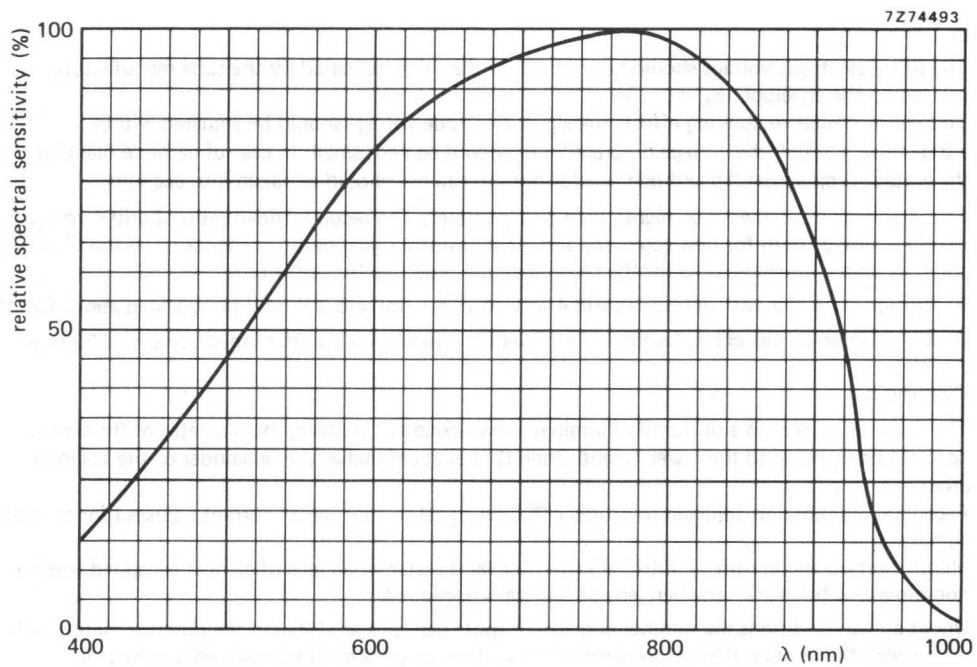

Fig. 1 Typical spectral response curve, C2.

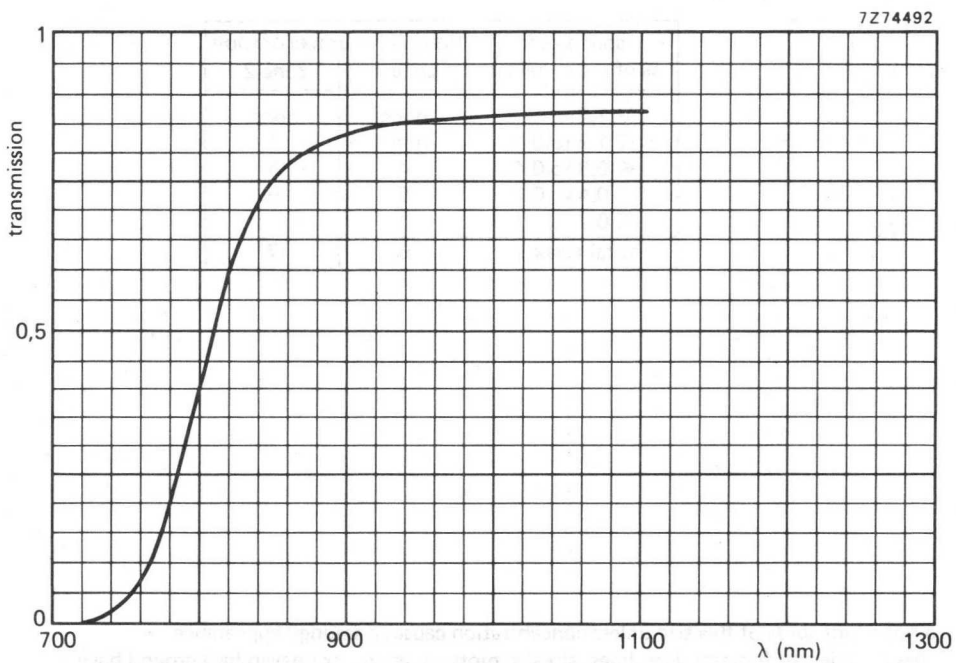

Fig. 2 Transmission curve of infrared filter (Hoya IR80).

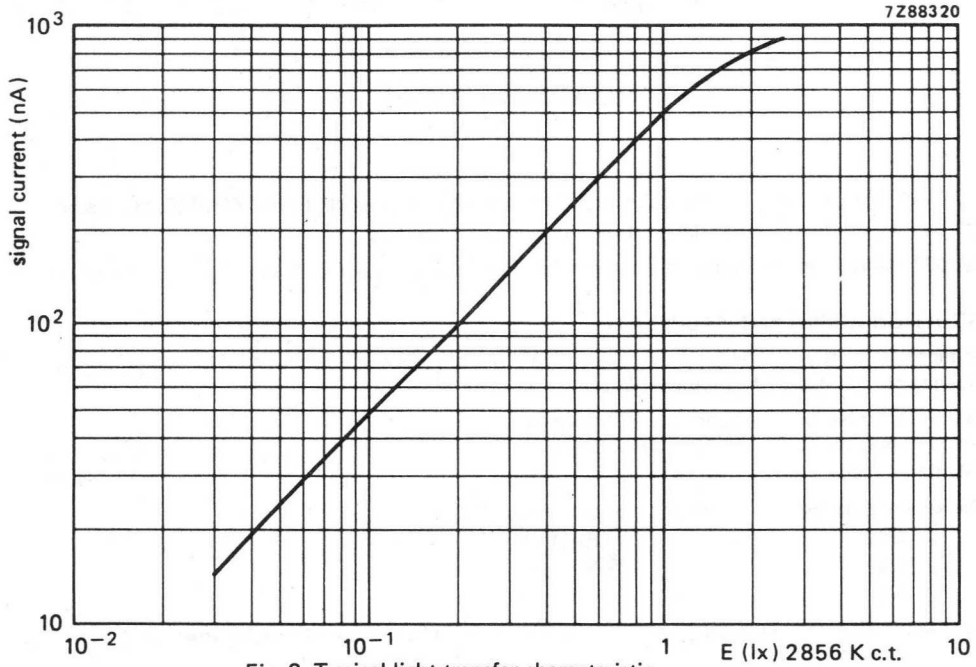

Fig. 3 Typical light transfer characteristic.

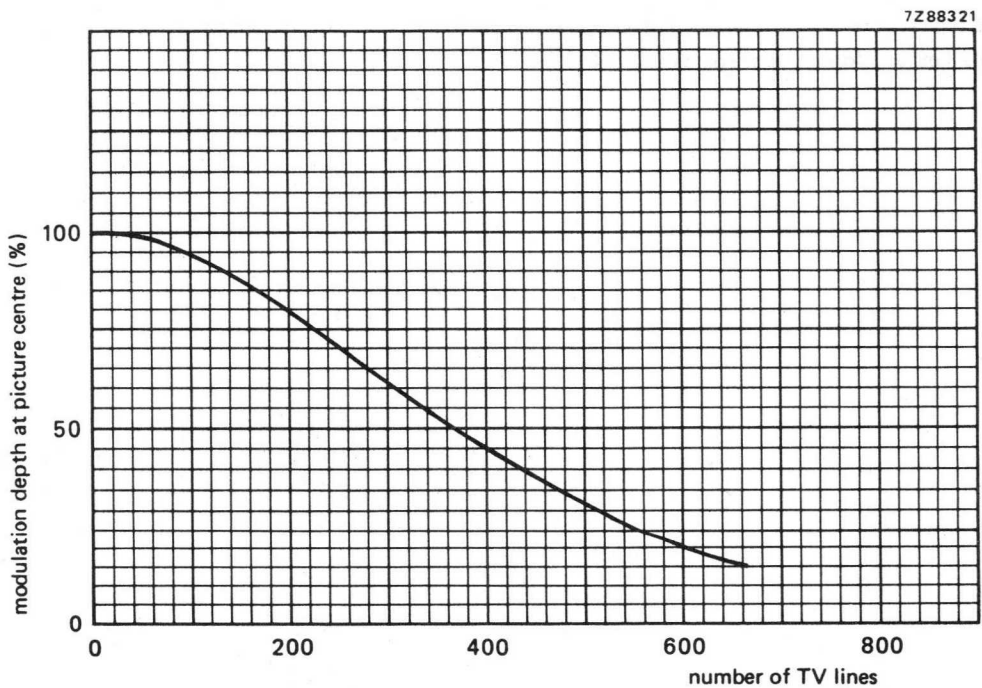

Fig. 4 Typical uncompensated square wave response curve. Highlight signal current 200 nA, beam current 200 nA.

CAMERA TUBE

Newwicon® camera tube, mechanically and electron-optically identical to the XQ1440, the major difference being the radiation resistant (anti-browning) faceplate.

The XQ1444 is intended for use in cameras which are subjected to high doses of ionizing radiation.

RADIATION RESISTANT FACEPLATE

The faceplate of the XQ1444 is made of a special type of glass and does not turn brown under the influence of high doses of gamma radiation.

- Maximum dose rate per hour: 5×10^5 Röntgen/hour
- Maximum cumulative dose: 5×10^7 Röntgen
- Maximum decrease of transmission of faceplate:

Maximum decrease	After a cumulative dose of
3%	10^5 Röntgen
10%	10^6 Röntgen
15%	5×10^7 Röntgen

- Maximum increase of dark current at 25 °C after a cumulative dose of 5×10^7 Röntgen: 75%

SENSITIVITY

The typical sensitivity of the XQ1444 is approximately 10% less than for the XQ1440.

For all other information see data of XQ1440.

CAMERA TUBE

Newvicon® camera tube, electrically and electron-optically identical to the XQ1440; the only difference being the overall length.

The XQ1445 is intended for use in cameras for security and surveillance, where its high sensitivity and resolution, low power consumption and short length are essential.

For the electrical and mechanical data of the XQ1445 refer to those of the XQ1440.

MECHANICAL DATA

Dimensions in mm

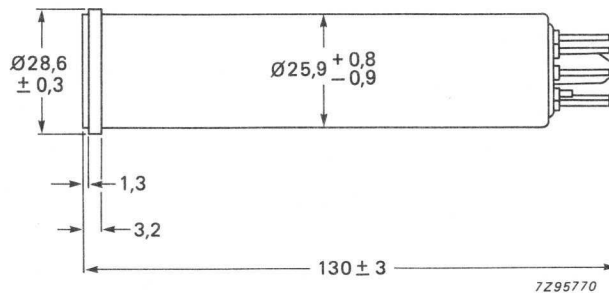

ACCESSORIES

Deflection and focusing coil unit

KV9G or equivalent

CAMERA TUBE

NEWVICON® television camera tube with a photoconductive target composed of cadmium and zinc tellurides featuring high resolution and an extremely high sensitivity.

The XQ1601 is a ½ in diameter camera tube with very low heater power, separate mesh, electrostatic focusing and magnetic deflection. It is mechanically interchangeable with vidicons like XQ1600 and has the same pin connections.

The XQ1601 is intended for use in ultra-compact cameras for security and surveillance applications, for example, where its high sensitivity and resolution, small size and low power consumption are essential.

QUICK REFERENCE DATA

Separate mesh		
Focusing		electrostatic
Deflection		magnetic
Diameter		13,5 mm
Length	max.	85 mm
Spectral response, max. at	approx.	750 nm
cut-off at	approx.	900 nm
Heater		2,8 V, 107 mA
Limiting resolution		450 TV lines

OPTICAL

Diagonal of quality rectangle on photoconductive layer (aspect ratio 3 : 4) 7,75 mm

Orientation of image on photoconductive layer:

The direction of the horizontal scan should be essentially parallel to the plane passing through the short index pin and the longitudinal axis of the tube.

Spectral response, curve see Fig. 1

Faceplate		
thickness		1,6 mm
refractive index		1,611

HEATING Indirect by a.c. or d.c.; parallel or series supply

Heater voltage	V_f	$2,8 \text{ V} \pm 5\%$
Heater current, at $V_f = 2,8 \text{ V}$	I_f	$107 \text{ mA} \pm 10\%$

When the tube is used in a series heater chain, the heater voltage must not exceed an r.m.s. value of 3,5 V when the supply is switched on.

® Registered Trade Mark for television camera tubes.

CAPACITANCES

Signal electrode to all

$$C_{as} \approx 1,5 \text{ pF}$$

This capacitance, which is effectively the output impedance of the tube, increases when the tube is inserted into the deflection coil unit.

MECHANICAL DATA

Dimensions in mm

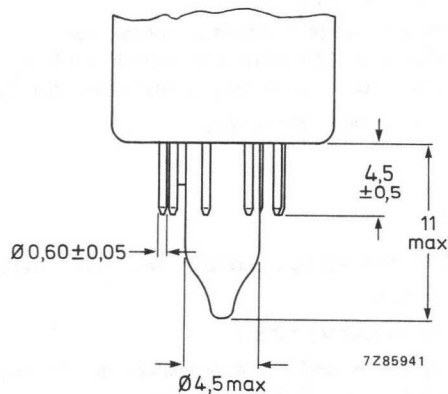
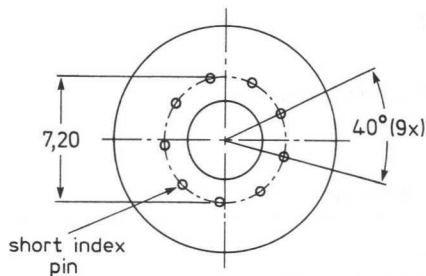
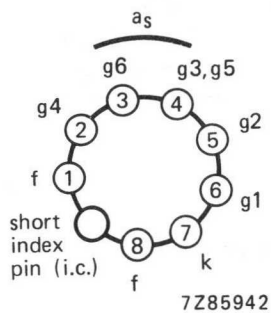
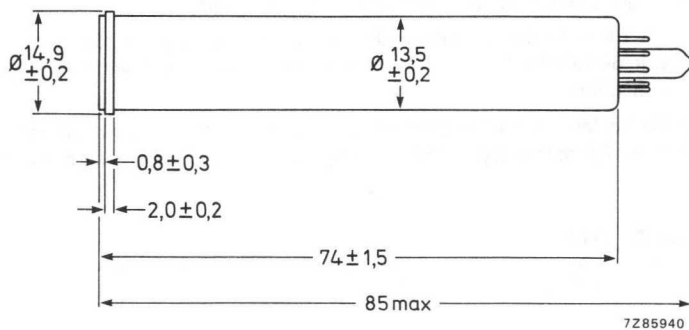

Mounting position: any

Net mass: $\approx 12 \text{ g}$

ACCESSORIES

Socket	special miniature 8-pin, type 56600 or equivalent
Deflection coil unit	KV29E or equivalent

DEFLECTION

magnetic

FOCUSING

electrostatic

LIMITING VALUES

(Absolute maximum rating system) for scanned area of 4,65 mm x 6,2 mm.

"Full-size scanning" i.e. scanning of a 4,65 mm x 6,2 mm area of the photoconductive layer should always be applied. Underscanning, i.e. scanning of an area smaller than 4,65 mm x 6,2 mm, may cause permanent damage to the specified full-size area.

Signal electrode voltage	V_{as}	max.	50 V*
Grid 6 voltage	V_{g6}	max.	600 V
Grid 4 (beam focus electrode) voltage	V_{g4}	max.	350 V
Grid 3 and 5 voltage	$V_{g3,g5}$	max.	450 V
Grid 2 voltage	V_{g2}	max.	400 V
Grid 1 voltage, negative	$-V_{g1}$	max.	300 V
positive	V_{g1}	max.	0 V
Cathode-to-heater voltage peak positive	V_{kfp}	max.	125 V
peak negative	$-V_{kfp}$	max.	10 V
Output current, peak	I_{asp}	max.	500 nA**
Faceplate illumination	E	max.	10 000 lx ▲
Faceplate temperature, storage and operation	T	max.	70 °C
Cathode heating time before drawing cathode current	t_h	min.	1 min

* Newvicon tubes do not permit automatic sensitivity control by means of regulation of the signal electrode voltage. Adequate control is therefore to be achieved by other means (iris control and neutral density filters). If the tube is applied in cameras originally designed for vidicon tubes, the automatic sensitivity control circuitry should be made inoperative and the signal electrode voltage set to the value indicated in the test sheet. See General Operational Notes.

** Video amplifiers should be capable of handling signal electrode currents of this magnitude without overloading the amplifier or distorting the picture.

▲ White light, uniformly diffused over entire tube face.

Care must be taken not to focus the solar image on the target through a lens opening wider than $f : 11$ to avoid instantaneous breakdown.

OPERATING CONDITIONS AND PERFORMANCE

For a scanned area of 4,65 mm x 6,2 mm, a faceplate temperature of 25 to 35 °C and standard TV scanning rate.

Conditions

			notes
Signal electrode voltage	V_{as}	10 to 35 V	1
Grid 6 (decelerator) voltage	V_{g6}	500 V	2
Grid 4 (beam focus electrode) voltage	V_{g4}	31 to 55 V	3
Grid 3 and 5 voltage	V_{g3+5}	250 V	2
Grid 2 voltage	V_{g2}	300 V	
Grid 1 voltage for picture cut off (no blanking applied)	V_{g1}	-100 to -40 V	
Blanking voltage, peak to peak			
when applied to grid 1		75 V	
when applied to cathode		20 V	
Flux density of adjustable alignment coil or magnet		0 to 0,4 mT	

Performance

		min.	typ.	max.	
Dark current (at 25 °C)			3	4,5	nA
Signal current, white light faceplate illumination 1 lx c.t. 2856 K	I_s	90	110		nA
Decay: residual signal current 60 ms after cessation of the illumination initial signal current 100 nA			10		%
Limiting resolution at picture centre			480		TV lines 4
Average γ of transfer characteristic			≈ 1		
Spurious signals (spots and blemishes)					5

Notes

1. The signal electrode voltage should be adjusted to the value indicated by the tube manufacturer as printed on the envelope ($V_{esi} = \quad V$). To minimize picture sticking effects the signal electrode should be adjusted within a tolerance of $\pm 2 V$; the voltage drop across R_1 should be kept small. In the case of cathode blanking the voltage drop across the cathode resistor during read-out should be taken into account.
2. Grid 6 voltage must always be higher than grids 3 + 5 voltage.
The recommended ratio of grid 6 voltage to grids 3 + 5 voltage for best geometry and most uniform signal output depends upon the type of coil used and will be 2 : 1 for the recommended type (see "Accessories").
3. Adjusted for correct electrical focus.
4. On EIA resolution test chart: faceplate illumination adjusted for a peak output current of 100 nA. The resolution is highly dependent on the coil used; the indicated figures are only valid for the recommended coil.

5. Conditions

The camera focused on a uniformly illuminated two-zone test pattern, the diameter of the centre zone (1) being equal to the raster height. Zone (2) being defined as the remainder of the scanned area.

Faceplate illumination adjusted to produce 100 nA signal current, beam current adjusted for correct stabilization.

Monitor set-up and contrast control adjusted for faint raster when lens of camera is capped and for non-blooming bright raster when lens of camera is uncapped.

Under above conditions the number and size of spots per zone visible in the monitor picture will not exceed the limits stated below. Both black and white spots must be counted, unless their contrast is less than 50% of peak white signal as observed on a waveform oscilloscope. Spots having a contrast $\geq 100\%$ are fully counted, spots having a contrast $> 50\%$ but $< 100\%$ will be considered as having half their actual size.

Spot size in % of raster height	Maximum number of spots	
	zone 1	zone 2
$> 1,2$	none	none
$\leq 1,2$ to 0,8	none	1
$\leq 0,8$ to 0,4	4	5
$\leq 0,4$ to 0,2	5	5
$\leq 0,2$	*	*
total (max.)	5	7

- * Do not count spots of this size unless concentration causes a smudgy appearance.
Tubes are rejected for: smudges, lines, streaks, mottled, grainy or uneven background having contrast $> 50\%$.

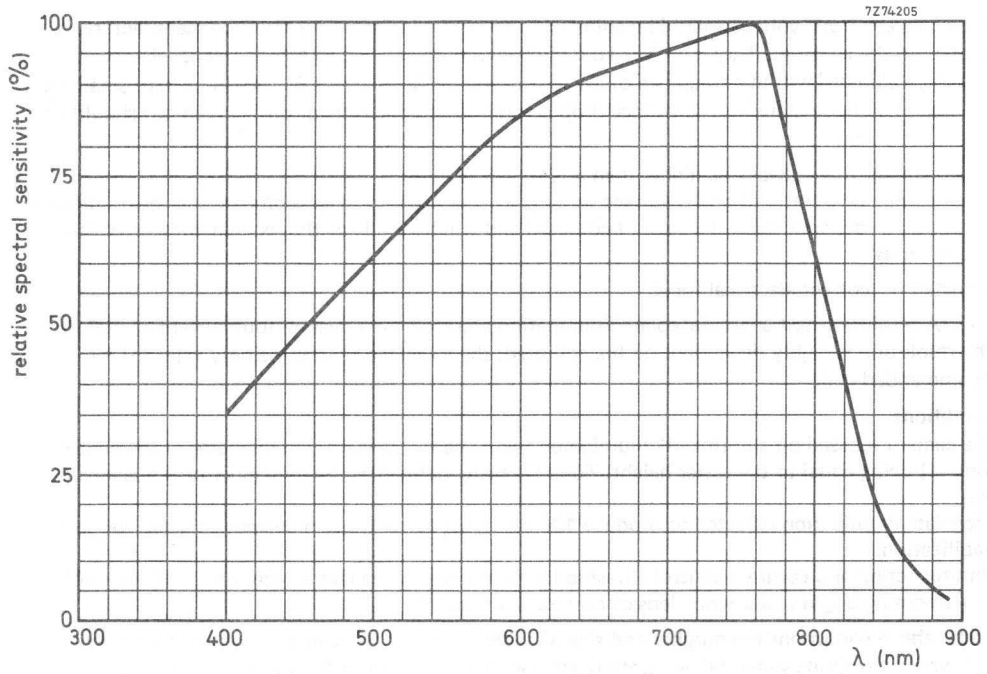

Fig. 1 Typical spectral response curve.

CAMERA TUBE

Newvicon® camera tube, mechanically and electron-optically identical to the XQ1601, the major difference being the radiation resistant (anti-browning) faceplate.

The XQ1602 is intended for use in cameras which are subjected to high doses of ionizing radiation.

RADIATION RESISTANT FACEPLATE

The faceplate of the XQ1602 is made of a special type of glass and does not turn brown under the influence of high doses of gamma radiation.

- Maximum dose rate per hour: 5×10^5 Röntgen/hour
- Maximum cumulative dose: 5×10^7 Röntgen
- Maximum decrease of transmission of faceplate:

Maximum decrease	After a cumulative dose of
3%	10^5 Röntgen
10%	10^6 Röntgen
15%	5×10^7 Röntgen

- Maximum increase of dark current at 25 °C after a cumulative dose of 5×10^7 Röntgen: 75%

SENSITIVITY

The typical sensitivity of the XQ1602 is approximately 10% less than for the XQ1601.

For all other information see data of XQ1601.

DEFLECTION UNITS

DEFLECTION UNIT FOR 1-inch VIDICON**QUICK REFERENCE DATA**

	inductance	resistance
Line deflection coils	1,6 mH	4,4 Ω
Frame deflection coils	70 mH	120 Ω
Focus coil	—	100 Ω

APPLICATION

The KV9G is for use in black and white cameras using front-loading 1-inch camera tubes.

DESCRIPTION

The deflection unit consists of deflection, focus coils and alignment ring magnets for 25 mm (1-inch) diameter vidicon, Newvicon® and similar television camera tubes (e.g. XQ1031, XQ1240, XQ1241 and XQ1440).

CATALOGUE NUMBER

The catalogue number is 9390 288 80000.

MECHANICAL DATA

Dimensions in mm

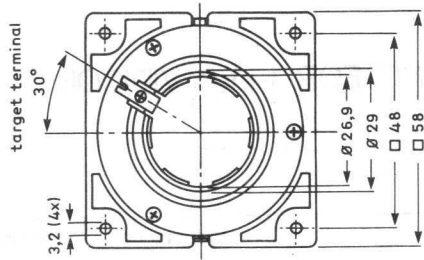

7Z86070A

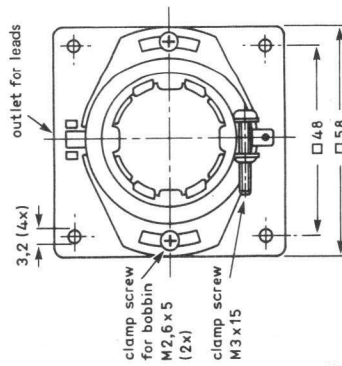
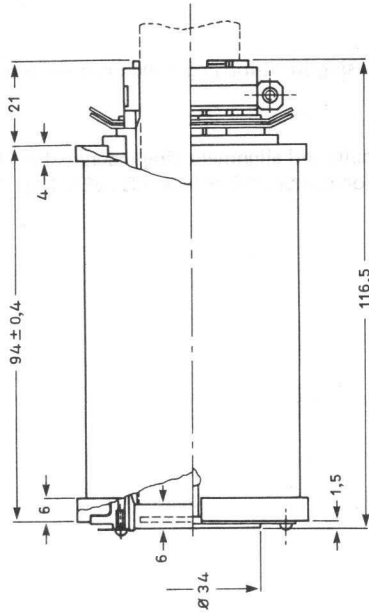
**Leads**

Line deflection coil red-blue
 Frame deflection coil green-yellow
 Focus coil brown-white
 Length from rear of unit 190 ± 10 mm
 The ends of the leads are stripped for 5 mm

Mass 500 g approx.**Alignment ring magnets**

Magnet rotation torque (with one ring fixed) 0,007 to 0,20 Nm

Flux density

max. 0,4 mT

min. 0,05 mT

Operating temperature -10 to +60 °C

ELECTRICAL DATA

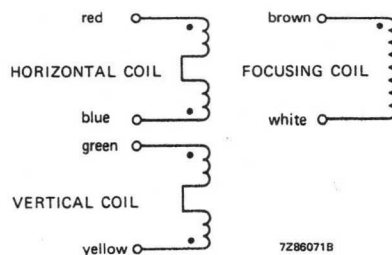

coils	inductance mH	resistance Ω
line deflection	$1,6 \pm 10\%$	$4,4 \pm 10\%$
frame deflection	$70 \pm 10\%$	$120 \pm 10\%$
focus*		$100 \pm 10\%$

Required currents for normal operation

Line deflection, peak-peak	$150 \text{ mA} \pm 5\%$
Frame deflection, peak-peak	$33 \text{ mA} \pm 5\%$
Focus current, at 4 mT	$90 \text{ mA} \pm 10\%$

Insulation resistance

Between coils, and between coils and earth, at 100 V d.c. $> 50 \text{ M}\Omega$

Geometric distortion

Barrel, keystone and pin cushion distortion are within 2% of picture height

Skew: $90^\circ \pm 2^\circ$ (4% of picture height).

* If a positive voltage is applied to the brown lead, the north-seeking pole of a compass should be attracted to the image end of the unit.

DEFLECTION UNIT FOR $\frac{2}{3}$ -inch CAMERA TUBES

QUICK REFERENCE DATA

	inductance	resistance
Line deflection coils	0,88 mH	2,9 Ω
Frame deflection coils	32 mH	146 Ω
Focus coil		55 Ω

APPLICATION

The KV12S is for use in black and white cameras using front loading $\frac{2}{3}$ -inch camera tubes.

DESCRIPTION

The deflection unit consists of deflection and focusing coils and alignment ring magnets for 17,7 mm ($\frac{2}{3}$ -inch) vidicon, Newvicon® and similar camera tubes (e.g. XQ1270, XQ1271, XQ1274).

CATALOGUE NUMBER

The catalogue number is 9390 258 20000.

MECHANICAL DATA

Dimensions in mm

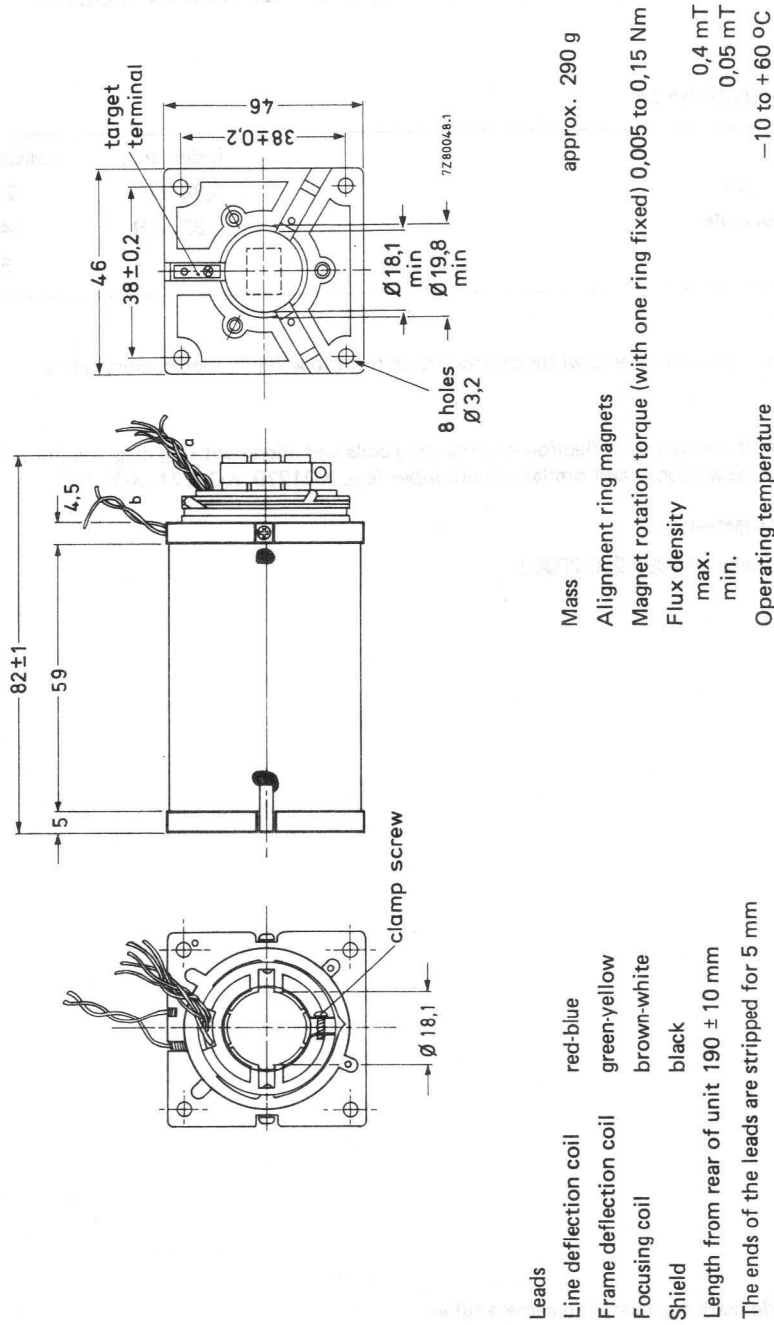

ELECTRICAL DATA

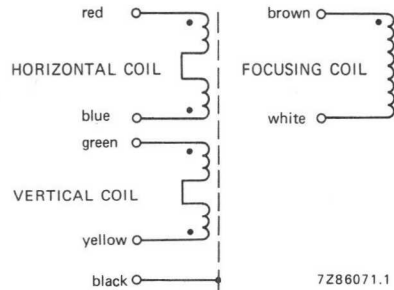

coils	inductance mH	resistance Ω
line deflection coils	$0,88 \pm 10\%$	$2,9 \pm 10\%$
frame deflection coils	$32 \pm 10\%$	$146 \pm 10\%$
focusing coil*		$55 \pm 10\%$

Required currents for normal operation

Line deflection, peak-peak	$150 \text{ mA} \pm 5\%$
Frame deflection, peak-peak	$20 \text{ mA} \pm 5\%$
Focusing, at 5 mT	$120 \text{ mA} \pm 10\%$

Insulation resistance

Between coils, and between coils and earth shield, at 100 V d.c.	$>50 \text{ M}\Omega$
--	-----------------------

Geometric distortion

Barrel, keystone and pin cushion distortion are within 2% at picture height.

Skew: $90^\circ \pm 2^\circ$ (4% of picture height).

* If a positive voltage is applied to the brown lead, the north-seeking pole of a compass should be attracted to the image end of the unit.

Faint, illegible text covering the majority of the page, likely bleed-through from the reverse side.

DEFLECTION UNIT FOR $\frac{2}{3}$ -inch CAMERA TUBES with electrostatic focusing

QUICK REFERENCE DATA

	inductance	resistance
Line deflection coils	0,9 mH	4,4 Ω
Frame deflection coils	26 mH	145 Ω

APPLICATION

The KV19G is for use in black and white cameras using front loading $\frac{2}{3}$ -inch camera tubes.

DESCRIPTION

The deflection unit consists of deflection coils and alignment ring magnets for 17,7 mm ($\frac{2}{3}$ -inch) vidicon, Newvicon[®] and similar camera tubes (e.g. XQ1272, XQ1275).

CATALOGUE NUMBER

The catalogue number is 9390 271 20000.

[®] Registered trade mark for television camera tubes.

MECHANICAL DATA

Dimensions in mm

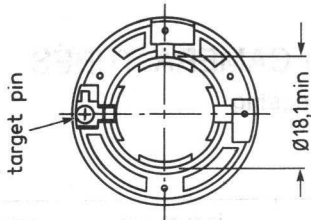
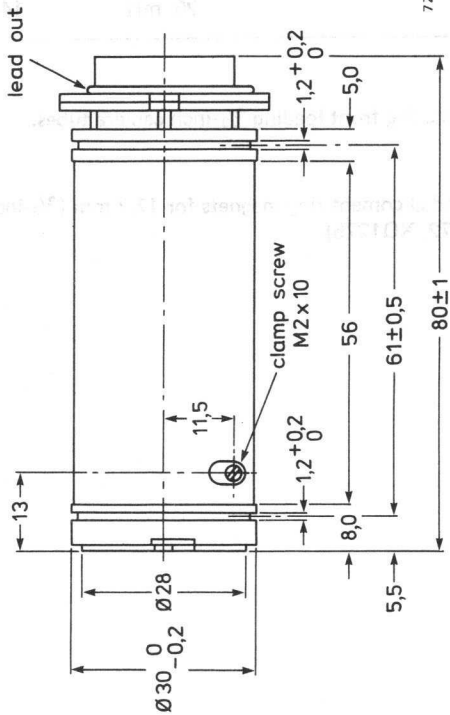
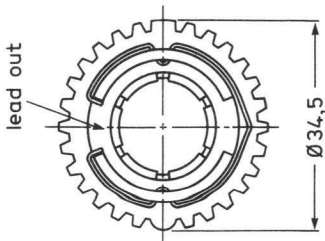

Leads

- Line deflection coil red-blue
- Frame deflection coil green-yellow
- Shield black
- Length from rear of unit 190 ± 10 mm
- The ends of the leads are stripped for 5 mm

Mass

approx. 50 g

Alignment ring magnets

Magnet rotation torque (with one ring fixed) 0,01 to 0,1 Nm

Flux density

max. 0,4 mT
min. 0,03 mT

Operating temperature

-10 to +60 °C

ELECTRICAL DATA

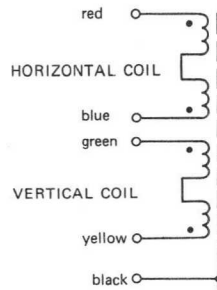

7Z86071.1B

coils	inductance mH	resistance Ω
line deflection coils	$0,9 \pm 10\%$	$4,4 \pm 10\%$
frame deflection coils	$26 \pm 10\%$	$145 \pm 10\%$

Required currents for normal operation

Line deflection, peak-peak

 $100 \text{ mA} \pm 5\%$

Frame deflection, peak-peak

 $16 \text{ mA} \pm 5\%$ **Insulation resistance**

Between coils, and between coils and earth shield

 $>50 \text{ M}\Omega$ **Geometric distortion**

Barrel, keystone and pin cushion distortion within 2% of picture height.

Skew: $90^\circ \pm 2^\circ$ (4% of picture height).

DEFLECTION UNIT FOR $\frac{2}{3}$ -inch CAMERA TUBES

with electrostatic focusing

QUICK REFERENCE DATA

	inductance	resistance
Line deflection coils	0,9 mH	4,6 Ω
Frame deflection coils	24,6 mH	147 Ω

APPLICATION

The KV19N is for use in black and white cameras using front-loading $\frac{2}{3}$ -inch camera tubes.

DESCRIPTION

The deflection unit consists of deflection coils and alignment ring magnets for 17,7 mm ($\frac{2}{3}$ -inch) diameter Vidicon, Newvicon[®] and similar television camera tubes (e.g. XQ1272, XQ1275).

CATALOGUE NUMBER

The catalogue number is 9390 312 20000.

Dimensions in mm

MECHANICAL DATA

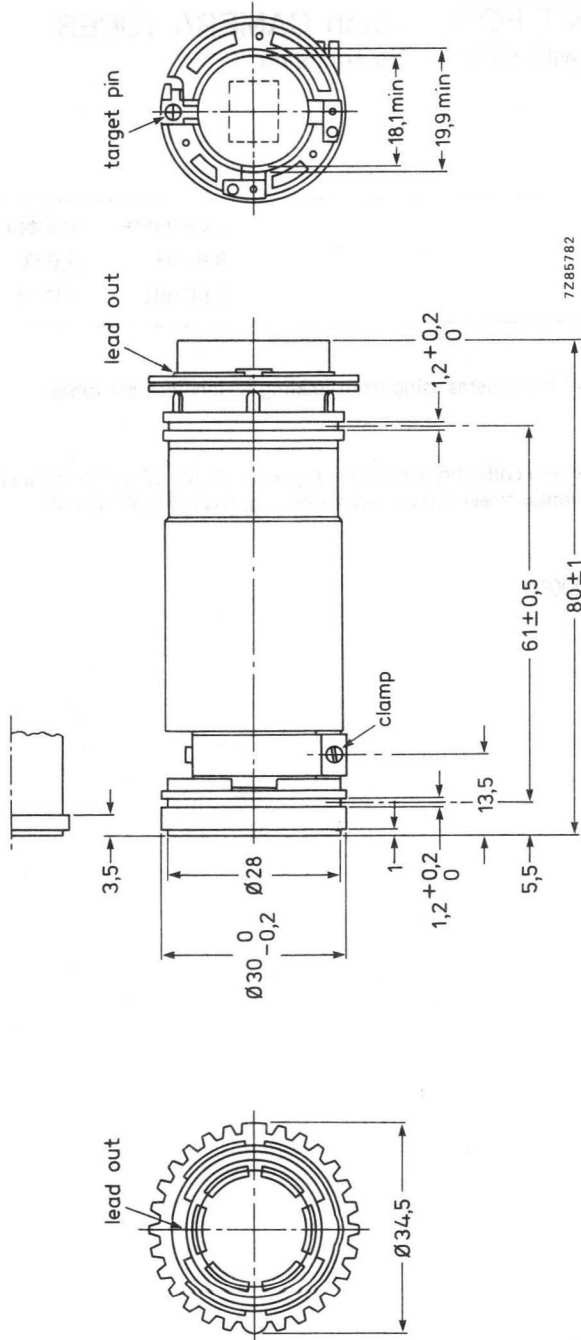

Leads

Line deflection coil red-blue
 Frame deflection coil green-yellow
 Length from rear of unit 190 ± 10 mm
 The ends of the leads are stripped for 5 mm

Mass 50 g approx.

Alignment ring magnets

Magnet rotation torque (with one ring fixed) 0,01 to 0,1 Nm

Flux density

max. 0,4 mT
 min. 0,03 mT

Operating temperature -10 to +60 °C

ELECTRICAL DATA

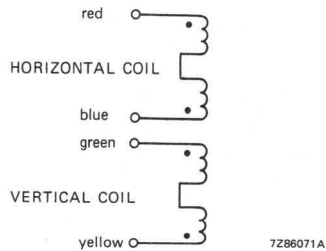

coils	inductance mH	resistance Ω
line deflection	$0,9 \pm 10\%$	$4,6 \pm 10\%$
frame deflection	$24,6 \pm 10\%$	$147 \pm 10\%$

Required currents for normal operation

Line deflection, peak-peak	$100 \text{ mA} \pm 5\%$
Frame deflection, peak-peak	$16 \text{ mA} \pm 5\%$

Insulation resistance

Between coils, and between coils and earth shield, at 100 V d.c.	$> 50 \text{ M}\Omega$
--	------------------------

Geometric distortion

Barrel, keystone and pin cushion distortion are within 2% of picture height.

Skew: $90^\circ \pm 2^\circ$ (4% of picture height).

1912

100	100	100
100	100	100
100	100	100
100	100	100

100

100

100

100

100

100

DEFLECTION UNIT FOR $\frac{2}{3}$ -inch CAMERA TUBES

QUICK REFERENCE DATA

	inductance	resistance
Line deflection coils	0,86 mH	3,2 Ω
Frame deflection coils	28 mH	146 Ω
Focus coil	—	55 Ω

APPLICATION

The KV22B is for use in black and white cameras using front-loading $\frac{2}{3}$ -inch camera tubes.

DESCRIPTION

The deflection unit consists of deflection, focus coils and alignment ring magnets for 17,7 mm ($\frac{2}{3}$ -inch) diameter vidicon, Newvicon[®] and similar television camera tubes (e.g. XQ1270, XQ1271 and XQ1274).

CATALOGUE NUMBER

The catalogue number is 9390 299 10000.

MECHANICAL DATA

Dimensions in mm

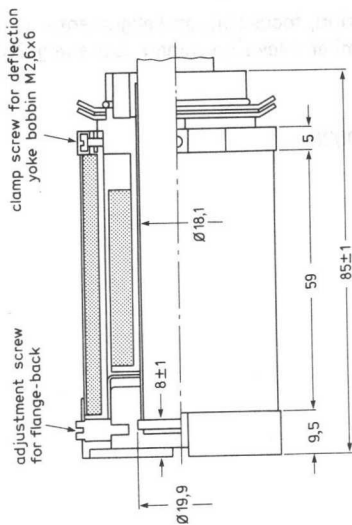
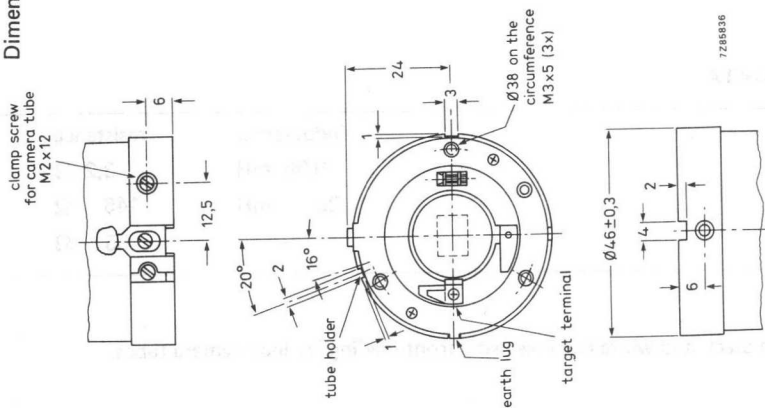

Leads

Line deflection coil	red-blue
Frame deflection coil	green-yellow
Focus coil	brown-white
Shield	black
Length from rear of unit	190 ± 10 mm

The ends of the leads are stripped for 5 mm

Mass 280 g approx.

Alignment ring magnets

Magnet rotation torque (with one ring fixed) 0,005 to 0,15 Nm

Flux density

max. 0,5 mT

min. 0,1 mT

Operating temperature -10 to +60 °C

ELECTRICAL DATA

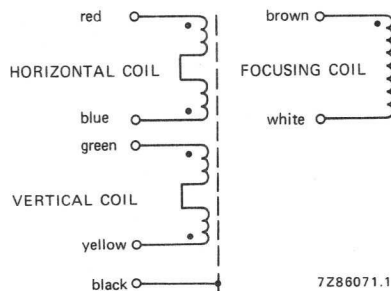

coils	inductance mH	resistance Ω
line deflection	$0,86 \pm 7\%$	$3,2 \pm 10\%$
frame deflection	$28 \pm 10\%$	$146 \pm 10\%$
focus*		$55 \pm 10\%$

Required currents for normal operation

Line deflection, peak-peak	$150 \text{ mA} \pm 5\%$
Frame deflection, peak-peak	$20 \text{ mA} \pm 5\%$
Focus, at 5 mT	$120 \text{ mA} \pm 10\%$

Insulation resistance

Between coils, and between coils and shield, at 100 V d.c. $> 50 \text{ M}\Omega$

Geometric distortion

Barrel, keystone and pin cushion distortion are within 2% of picture height.

Skew: $90 \text{ degrees} \pm 2 \text{ degrees}$ (4% of picture height).

* If a positive voltage is applied to the brown lead, the north-seeking pole of a compass should be attracted to the image end of the unit.

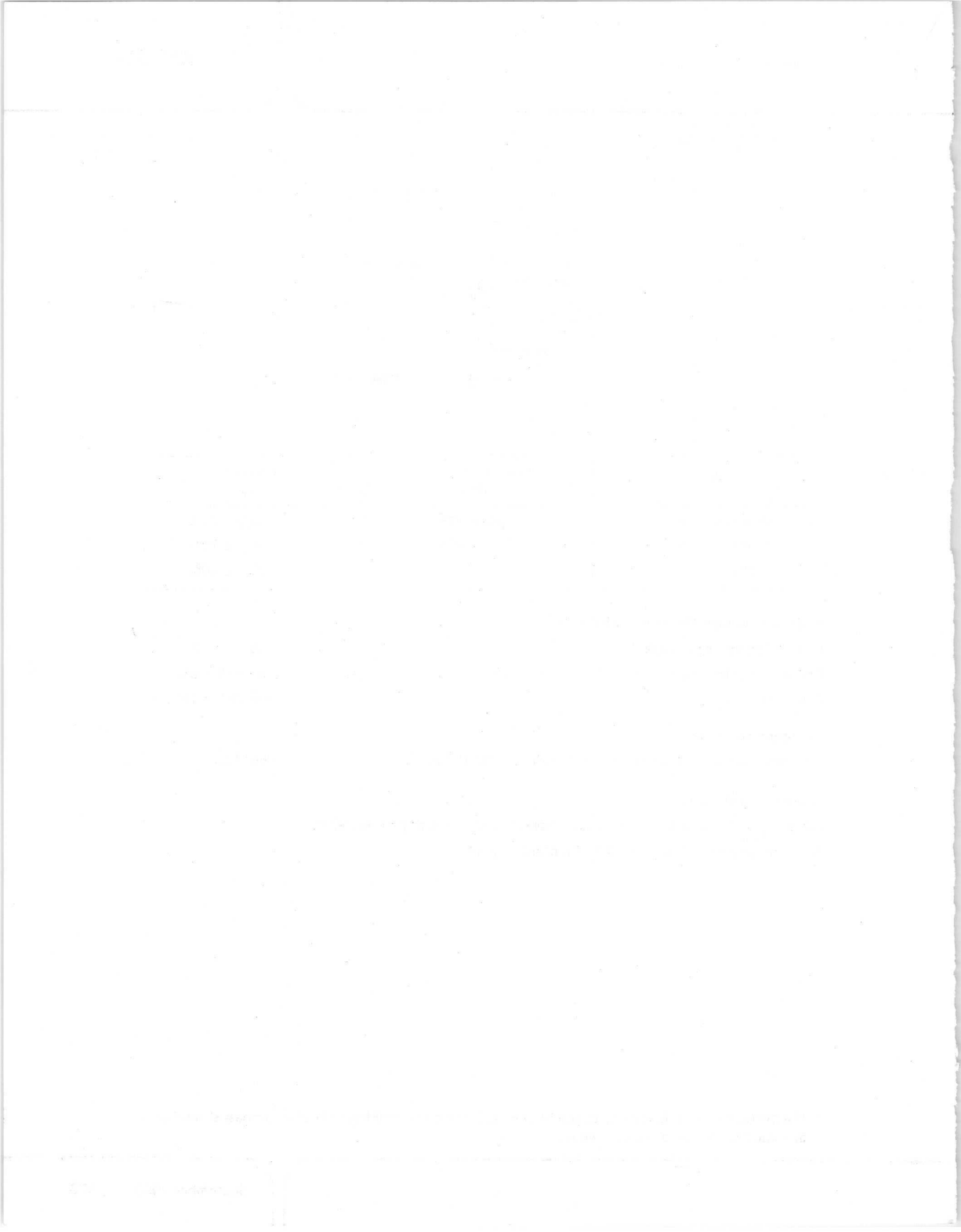

DEFLECTION UNIT FOR ½-inch CAMERA TUBES

with electrostatic focusing

QUICK REFERENCE DATA

	inductance	resistance
Line deflection coils	1,4 mH	11,3 Ω
Frame deflection coils	5,7 mH	60,7 Ω

APPLICATION

The KV29E is for use in black and white cameras using front-loading ½-inch camera tubes.

DESCRIPTION

The deflection unit consists of deflection coils and alignment ring magnets for 13,5 mm (½-inch) diameter Vidicon, Newvicon® and similar television camera tubes (e.g. XQ1600, XQ1601).

CATALOGUE NUMBER

The catalogue number is 9390 300 90000.

Dimensions in mm

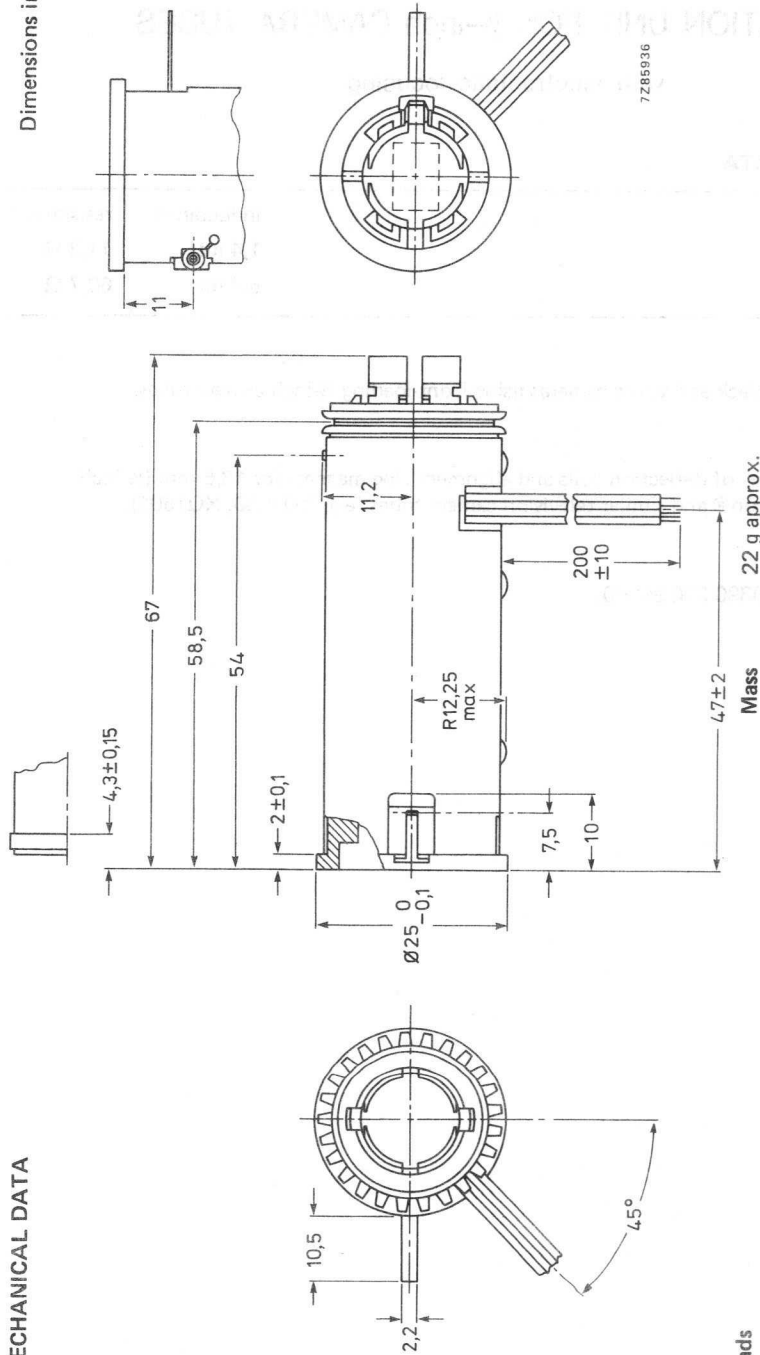

MECHANICAL DATA

Leads

- Line deflection coil red-blue
- Frame deflection coil orange-yellow
- Shield green

Length from rear of unit 200 \pm 10 mm

The ends of the leads are stripped for 5 mm

Mass 22 g approx.

Alignment ring magnets

Magnet rotation torque (with one ring fixed) 0,01 to 0,1 Nm

Flux density

max. 0,5 mT

min. 0,04 mT

Operating temperature -10 to +60 °C

ELECTRICAL DATA

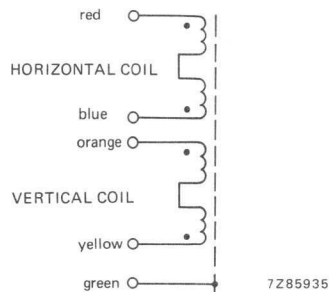

coils	inductance mH	resistance Ω
line deflection	$1,4 \pm 10\%$	$11,3 \pm 10\%$
frame deflection	$5,7 \pm 10\%$	$60,7 \pm 10\%$

Required currents for normal operation

Line deflection, peak-peak

 $70 \text{ mA} \pm 5\%$

Frame deflection, peak-peak

 $26 \text{ mA} \pm 5\%$ **Insulation resistance**

Between coils, and between coils and earth shield, at 100 V d.c.

 $> 50 \text{ M}\Omega$ **Geometric distortion**

Barrel, keystone and pin cushion distortion are within 1,5% of picture height.

Skew: $90^\circ \pm 1^\circ$ (2% of picture height).

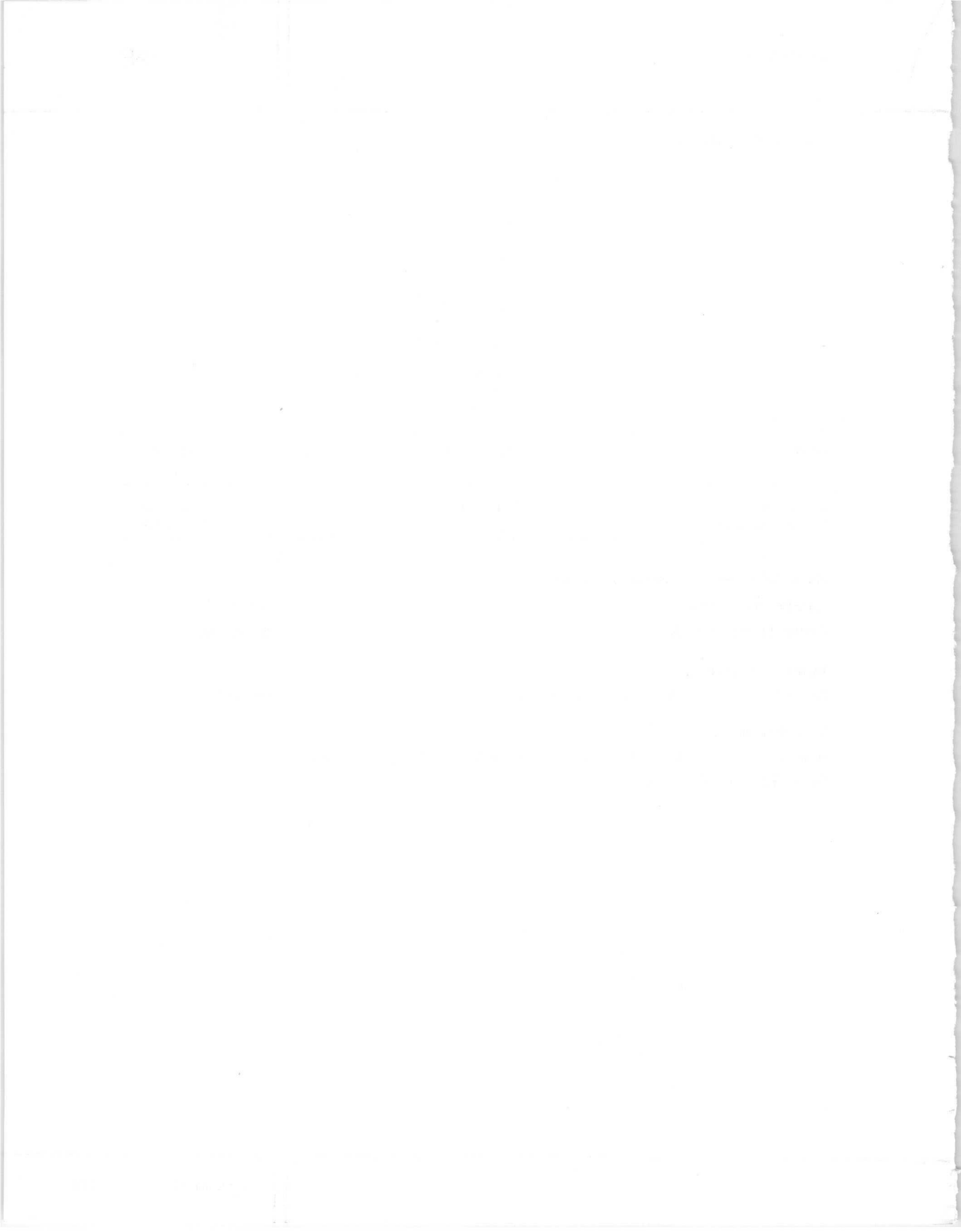

INDEX OF TYPE NUMBERS

type	kind*	page	type	kind*	page
KV9G	D	155	XQ1277	N	105
KV12S	D	159	XQ1278	N	111
KV19G	D	163	XQ1280	V	39
KV19N	D	167	XQ1285	V	51
KV22B	D	171	XQ1380	N	117
KV29E	D	175	XQ1381	N	118
XQ1031	V	9	XQ1440	N	119
XQ1032	V	9	XQ1442	N	127
XQ1240	V	15	XQ1443	N	135
XQ1241	V	15	XQ1444	N	142
XQ1270	V	21	XQ1445	N	143
XQ1271	V	27	XQ1590	V	63
XQ1272	V	33	XQ1600	V	69
XQ1274	N	81	XQ1601	N	145
XQ1275	N	89	XQ1602	N	151
XQ1276	N	97			

For Plumbicon television camera tubes see relevant Data Handbook.

* V = vidicon tube
 N = Newvicon tube
 D = deflection unit.

INDEX OF TYPE NUMBERS

Page	Year	Number	Year	Number	Page
108	1907	1007	1907	1007	108
111	1907	1010	1907	1010	111
98	1907	1011	1907	1011	98
81	1907	1012	1907	1012	81
113	1907	1013	1907	1013	113
110	1907	1014	1907	1014	110
133	1907	1015	1907	1015	133
138	1907	1016	1907	1016	138
140	1907	1017	1907	1017	140
143	1907	1018	1907	1018	143
81	1907	1019	1907	1019	81
81	1907	1020	1907	1020	81
147	1907	1021	1907	1021	147
151	1907	1022	1907	1022	151

Continued on next page

Continued on next page

NOTES

NOTES

NOTES

NOTES

NOTES

NOTES

The Mullard technical handbook system... ... a comprehensive data library

The Mullard technical handbook is made up of four sets of Books, each comprising several parts:-

Book 1 (light blue)	Semiconductor devices
Book 2 (orange)	Electronic tubes
Book 3 (green)	Components, materials and assemblies
Book 4 (dark blue)	Integrated circuits

Most of the devices for which full data is given in these books are those around which we would recommend equipment to be designed. Where appropriate, other types no longer recommended for new equipment designs but generally available for equipment production, are listed separately. Data sheets for these types may be obtained on request. Older devices for which data may be obtained on request are also included in the index of the appropriate part of each book.

Because the Technical handbook system forms a comprehensive data reference library the current Mullard Quick Reference Guide should always be consulted for details of the Mullard preferred range.

The data contained in these books is as accurate and up to date as possible at the time of going to press. It must be understood, however, that no guarantee can be given on the availability of the various devices, or that their specifications may not be changed before the next edition is published.

Each part is reviewed regularly, and revised and re-issued where necessary. Revisions to previous data are indicated by an arrow in the margin.

Requests for copies of the Quick Reference Guide and individual data sheets (please quote the type number) should be sent to:-

Technical Publications Department, Mullard Limited,
New Road, Mitcham, Surrey CR4 4XY. Telex 22194.

Prices and availability information for Mullard components should be obtained from Mullard House, or from one of the Mullard Distributors listed on the back cover.



The Mullard Data Base

For the equipment designer, technical information on electronic components is vital. Mullard market the widest range of components in the U.K., supported by a comprehensive information service – the Mullard Data Base.

Brief details are given here. For further information and an order form, please write to:-

**The Technical
Publication Department,**
Mullard Limited,
New Road, Mitcham,
Surrey CR4 4XY.

Regular Publications

Mullard Bulletin

A must for designers, this bi-monthly, newspaper-style publication briefly describes new components and offers further information on subjects of interest.

Consumer Electronics

A review, in newspaper style, published every four months. Articles and features of interest to those in the consumer electronics industry, with emphasis on television technology and allied subjects.

Technical Publications, Brochures, Leaflets and Catalogues

Mullard publish hundreds of publications on components and their application.

Make sure your name is on the mailing list for the Mullard Bulletin, which describes and offers new publications.



Prestel too!

Prestel Too!

All Mullard publications can be ordered directly via Prestel.

The Mullard Data Base begins, on page 556201.

Mullard technical handbook

Book 2 Electronic tubes

Book 2 consists of the following parts:

- Part 1a Colour tv, data and graphic display tubes and deflection units
- Part 1b Cathode-ray tubes
- Part 1c Monochrome tubes and deflection units
- Part 1d Wirewound components for tv and monitors
- Part 2a Plumbicon camera tubes and accessories
- Part 2b Geiger-Muller tubes
- Part 2c Vidicon and Newvicon camera tubes and deflection units
- Part 3 Photo and electron multipliers
- Part 4a Tubes for r.f. heating
- Part 4b Transmitting tubes for communications
- Part 4c High-power klystrons
- Part 4d Magnetrons for microwave heating
- Part 4e Ceramic tubes for communications

Electronic Components and Applications

A quarterly technical journal covering, in depth, developments in electronics based on the work of Philips, Signetics and Mullard laboratories. Please ask for a sample copy and subscription form.



Quick Reference Guide

All products marketed by Mullard are listed alphabetically and described briefly in our Quick Reference Guide.



Technical Data Service

This service provides detailed, up-to-date information on the characteristics and performance of Mullard components.

Subscribers to any or all of the four handbook sections receive all relevant handbooks, looseleaf binders, monthly mailings of new data sheets, and new handbook parts as they are published.

For those not wishing to subscribe to the Data Service, handbook parts can be purchased individually.

Individual data sheets are available free-of-charge, and can be obtained by quoting the type number.

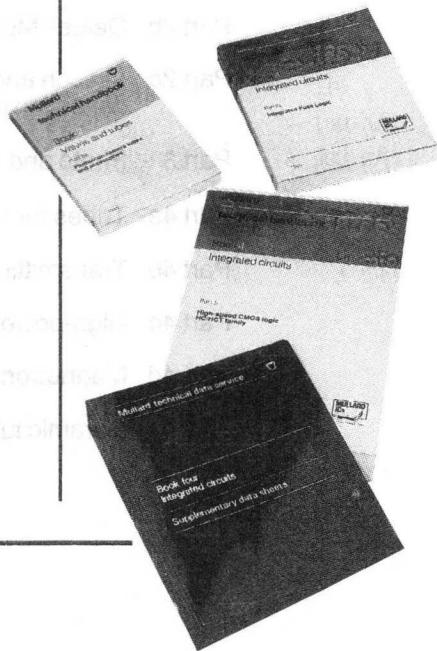

**Mullard Data Base:
Prestel 556201**

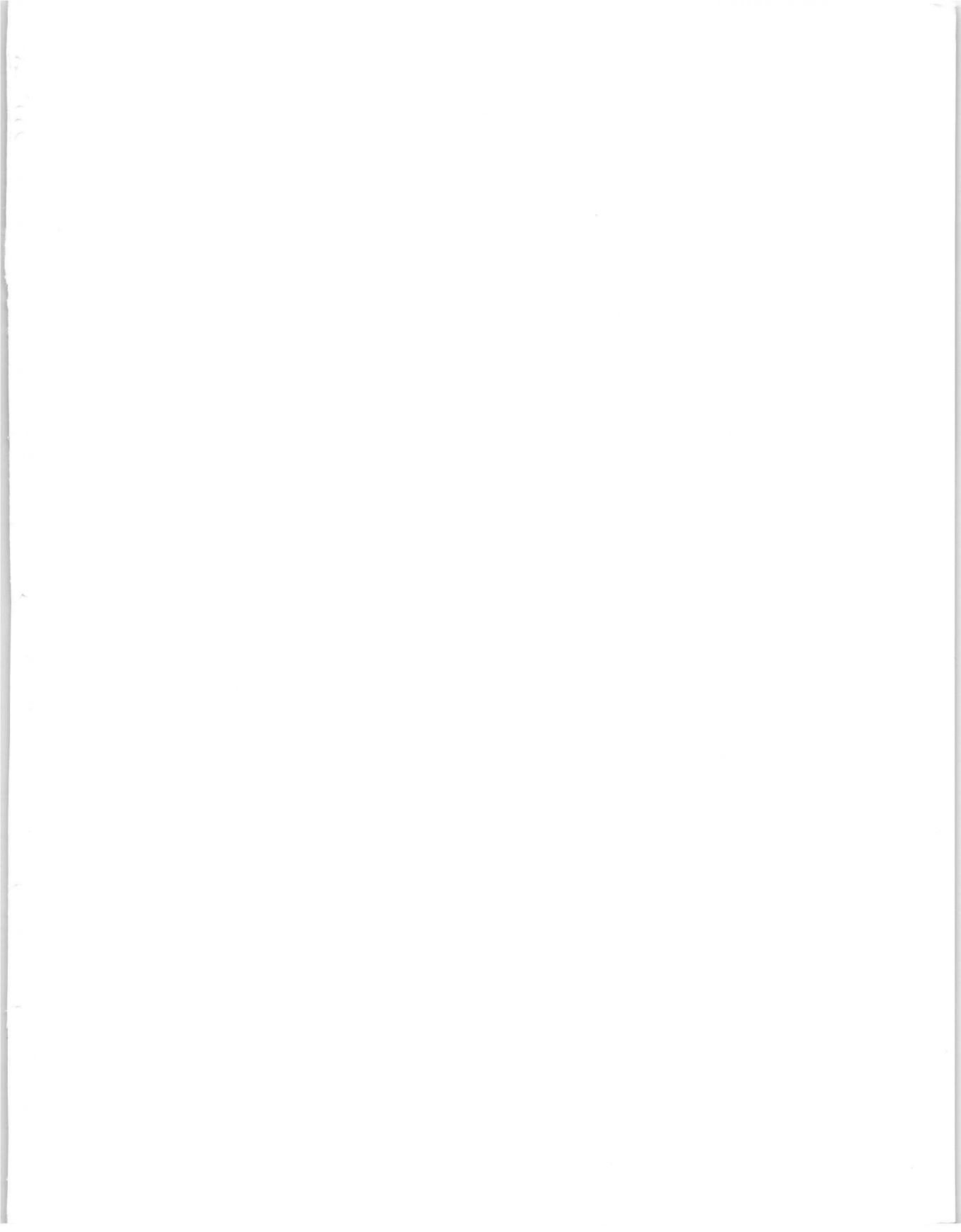

Mullard



technical handbook

Book 2



Alrad Instruments Ltd.

Turnpike Road Industrial Estate, Newbury, Berks. RG13 2NS.
Easylink: 946240 quote: 19005205

Mullard Mullard Limited, Mullard House, Torrington Place,
London WC1E 7HD. Telephone: (01) 580 6633. Telex: 264341.

Mullard manufacture and market electronic components under their own name and those of associated companies.

