



X-BAND MAGNETRON

Service Type CV2186

The data should be read in conjunction with the Magnetron Preamble.

ABRIDGED DATA

Fixed frequency pulse magnetron

Frequency range	9420 to 9500	MHz
Typical peak output power	40	kW
Magnet		separate
Output	British X-band waveguide (1.000 x 0.500 inch internal)	
Coupler		special
Cooling		forced-air

GENERAL

Electrical

Cathode		indirectly heated
Heater voltage (see note 1)	6.3	V
Heater current at 6.3V	0.8	A
Heater starting current, peak value, not to be exceeded	2.5	A max
Cathode heating time (minimum)	3.0	min

Mechanical

Overall dimensions	9.077 x 3.400 x 3.240 inches max 230.6 x 86.36 x 82.30mm max
Net weight	1½ pounds (0.7kg) approx
Mounting position	any

Cooling (see note 2) forced-air

MAXIMUM AND MINIMUM RATINGS (Absolute values)

These ratings cannot necessarily be used simultaneously, and no individual rating should be exceeded.

	Min	Max	
Magnetic field (see note 3)	4500	5200	gauss
Heater voltage (see note 1)	6.0	6.6	V
Heater starting current (peak)	—	2.5	A
Anode voltage (peak)	—	14	kV
Anode current (peak)	—	12	A
Input power (mean) (see note 4)	—	140	W
Duty cycle	—	0.001	
Pulse length	—	1.0	μ s
Rate of rise of voltage pulse (see note 6)	—	200	kV/ μ s
Anode temperature (see note 2)	—	^a 100	$^{\circ}$ C
V.S.W.R. at the output coupler	—	1.5:1	

TYPICAL OPERATION

Operational Conditions

	Condition 1	Condition 2	
Magnetic field (see note 3)	4850 \pm 50	4850 \pm 50	gauss
Heater voltage	0	0	V
Anode current (peak)	10	10	A
Pulse length	1.0	0.25	μ s
Pulse repetition rate	1000	1500	p.p.s.
Rate of rise of voltage pulse	200	200	kV/ μ s

Typical Performance

Anode voltage (peak)	13	13	kV
Output power (peak)	40	40	kW
Output power (mean)	40	15	W

TEST CONDITIONS AND LIMITS

The valve is tested to comply with the following electrical specification.

Test Conditions

Magnetic field	4850	gauss
Heater voltage (for test)	0	V
Anode current (mean)	10	mA
Duty cycle	0.001	
Pulse length (see note 5)	1.0	μ s
V.S.W.R. at the output coupler	1.1:1	
Rate of rise of voltage pulse (see note 6)	150	kV/ μ s

Limits

	Min	Max	
Anode voltage (peak)	11	14	kV
Output power (mean)	30	—	W
Frequency (see note 7)	9420	9500	MHz
R.F. bandwidth at ¼ power	—	2.5	MHz
Frequency pulling (v.s.w.r. not less than 1.5:1)	—	15	MHz
Stability (see note 8)	—	0.2	%
Heater current			see note 9
Temperature coefficient of frequency			see note 10



LIFE TEST

The quality of all production is monitored by the random selection of valves which are then life-tested under Typical Operation Condition 1. If the valve is to be run continuously under conditions other than those specified herein, English Electric Valve Company Ltd. should be consulted to verify that the life of the valve will not be impaired.

End of Life Criteria (under Test Conditions above)

Anode voltage (peak)	10	kV min
Output power (mean)	25	W min
R.F. bandwidth at ¼ power	3.0	MHz max
Frequency	9420 to 9500	MHz
Stability (see note 8)	0.5	% max

NOTES

1. With no anode input power.
The heater voltage must be reduced within 5 seconds after the application of h.t. according to the following schedule:

$$V_h = 6.3 \sqrt{1 - \frac{P_i}{150}} \text{ volts}$$

where P_i = mean input power in watts.

The valve heater must be protected against arcing by the use of a minimum capacitance of 4000pF shunted across the heater directly at the input terminals; in some cases a capacitance as high as 2 μ F may be necessary depending on the equipment design. For further details see the preamble to this section.

2. The anode temperature must be kept below the limit specified by means of a suitable flow of air over the cooling fins.
3. The valve is designed for use with a separate magnet (not supplied). The position of the magnet must be adjusted so that the axis of the field is in line with the axis of the anode. The user is invited to consult English Electric Valve Company Ltd. on the choice of magnets.
4. The various parameters are related by the following formula:

$$P_i = i_{apk} \times v_{apk} \times D_u$$

where P_i = mean input power in watts

i_{apk} = peak anode current in amperes

v_{apk} = peak anode voltage in volts

and D_u = duty cycle.

5. Tolerance $\pm 10\%$.
6. Defined as the steepest tangent to the leading edge of the voltage pulse above 80% amplitude. Any capacitance in the viewing system must not exceed 6.0pF.
7. Other frequency ranges can be supplied on request.
8. With the valve operating into a v.s.w.r. of 1.15:1. Pulses are defined as missing when the r.f. energy level is less than 70% of the normal energy level in a 0.5% frequency range. Missing pulses are expressed as a percentage of the number of input pulses applied during the period of observation after a period of 10 minutes operation.
9. Measured with heater voltage of 6.3V and no anode input power, the heater current limits are 0.7A minimum, 0.9A maximum.
10. Design test only. The maximum frequency change with anode temperature change (after warming) is $-0.25\text{MHz}/^\circ\text{C}$.

TYPICAL PERFORMANCE CHART

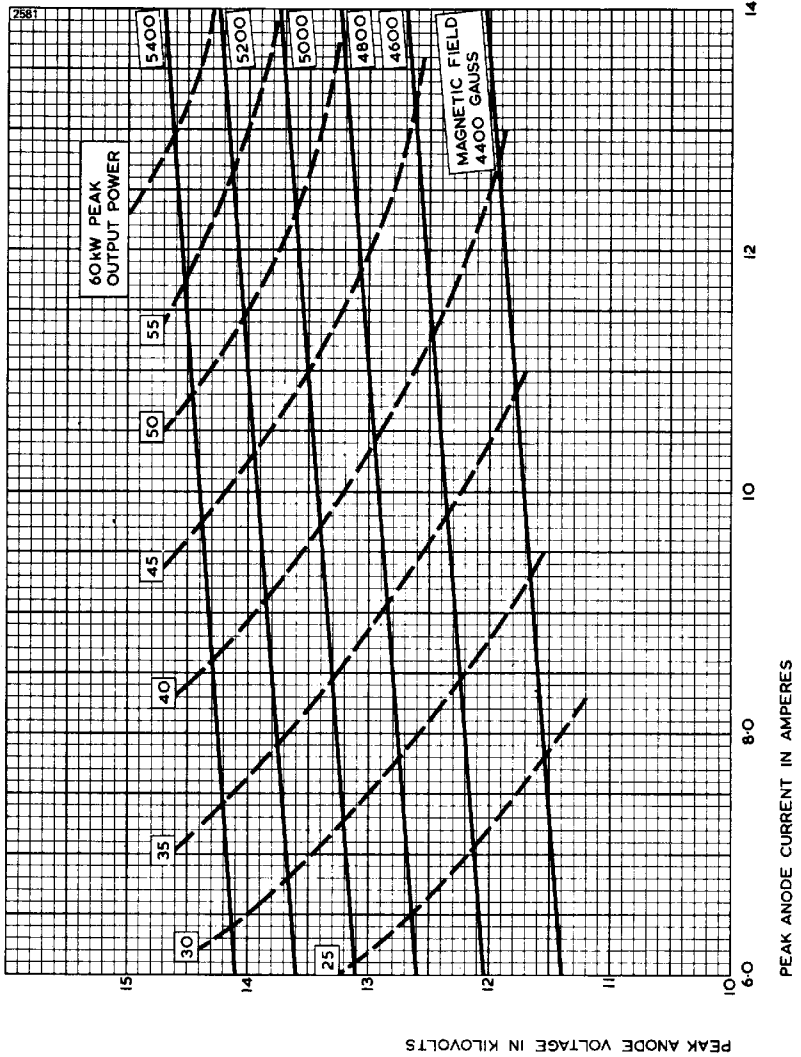

OUTLINE

2577

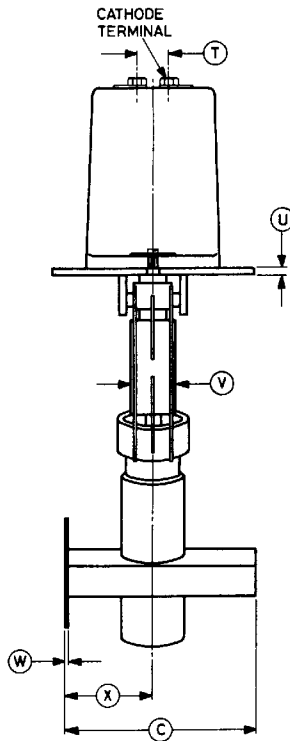
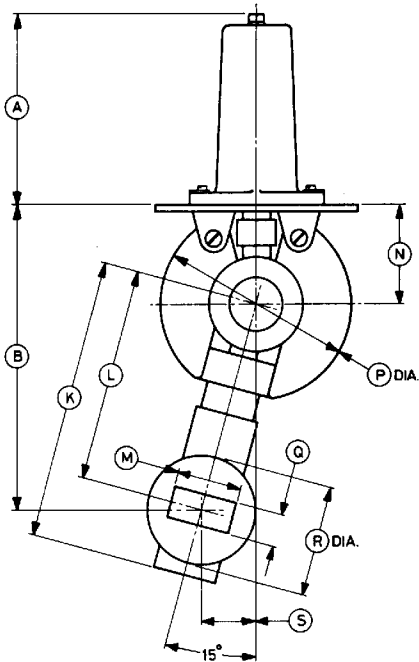
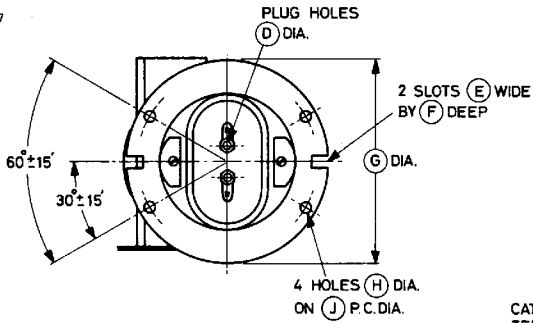

Outline Dimensions (All dimensions without limits are nominal)

Ref	Inches	Millimetres
A	3.000 ± 0.062	76.20 ± 1.57
B	4.800 ± 0.020	121.92 ± 0.51
C	3.062	77.77
D	0.169 ± 0.002	4.293 ± 0.051
E	0.188 ± 0.001	4.775 ± 0.025
F	0.312	7.92
G	3.240 ± 0.001	82.296 ± 0.025
H	0.201	5.11
J	2.875 ± 0.010	73.03 ± 0.25
K	4.437	112.7
L	3.355 ± 0.020	85.22 ± 0.51
M	1.000	25.40
N	1.562 ± 0.020	39.67 ± 0.51
P	3.000 ± 0.062	76.20 ± 1.57
Q	0.500	12.70
R	1.750	44.45
S	0.870 ± 0.020	22.10 ± 0.51
T	0.500 ± 0.010	12.70 ± 0.25
U	0.125	3.18
V	0.620 max	15.75 max
W	0.064	1.63
X	1.387 ± 0.020	35.23 ± 0.51

Millimetre dimensions have been derived from inches.

