



EITEL-McCULLOUGH, INC.
SAN CARLOS, CALIFORNIA

TENTATIVE DATA
X-1098
VOLTAGE TUNABLE
MAGNETRON
FREQUENCY
885-1460 Mc
MINIMUM OUTPUT POWER
32 mW

TYPICAL PERFORMANCE

ELECTRICAL

Frequency Range	- - - - -	885-1460 kMc
Anode Voltage	- - - - -	900-1420 V
Cathode Current	- - - - -	2-6 mA
Typical Output Power	- - - - -	45-80 mW
Anode FM Sensitivity	- - - - -	1.1 Mc/V
Injection Anode Voltage	- - - - -	100 V
Injection Anode Current	- - - - -	0.0 mA
Heater Voltage (AC)	- - - - -	6.3 V
Heater Current (AC)	- - - - -	0.8 A
Load Impedance	- - - - -	50 ohms
Service	- - - - -	cw

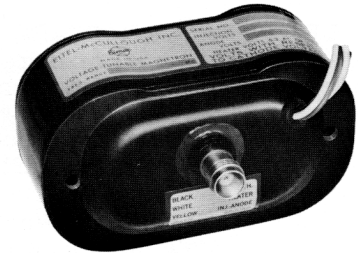

LOW NOISE L-BAND OSCILLATOR

***MAXIMUM RATINGS**

Anode Voltage	- - - - -	1800 V
Cathode Current	- - - - -	20 mA
Injection Anode Voltage	- - - - -	300 V
Injection Anode Current	- - - - -	1 mA

*Damage to the tube may occur if maximum ratings are exceeded.

MECHANICAL

Operating Position	- - - - -	Any
Cooling	- - - - -	Conduction
Electrical Connection	- - - - -	Flexible Leads
RF Output Coupling	- - - - -	Type N Jack
Weight	- - - - -	3.5 Pounds

ENVIRONMENTAL

Vibration	- - - - -	10 G-(to 2 kc)
Shock	- - - - -	100 G-(11 ms)
Altitude	- - - - -	70,000 ft.

OUTLINE DIMENSIONS

Height	- - - - -	3 inches
Width	- - - - -	2.1 inches
Length	- - - - -	4.5 inches

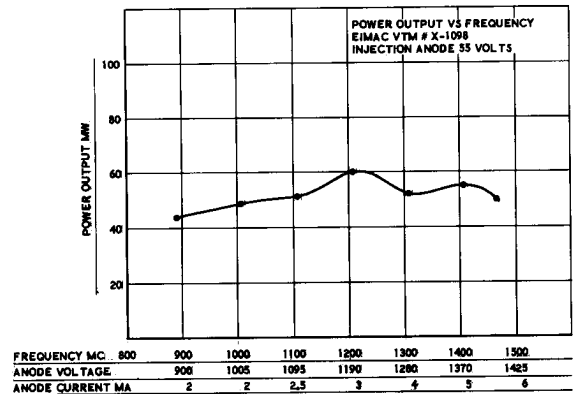



APPLICATION NOTES

- COOLING:** To insure optimum tube performance the magnet temperature should be maintained below 70°C.
- PROXIMITY OF FERROUS MATERIALS:** To minimize variations in performance, ferrous materials should be kept at least 6 inches from the magnetron package. Modulation of the tube may be produced by rotating ferrous materials and such parts as fans, shafts and couplings should be placed as far from the magnetron package as possible. Transformers and chokes should not be placed in such close proximity to the tube that their stray magnetic fields will interfere with the magnetron operation.
- TEMPERATURE STABILITY:** The permanent magnet for the X-1098 has been temperature stabilized to minimize frequency changes caused by variations in the ambient temperature. The temperature/frequency coefficient for the X-1098 package is typically .006% of the operating frequency per degree Centigrade. Thus, for an operating frequency of 1450 megacycles, the temperature/frequency coefficient is typically 300 kilocycles per degree Centigrade. A positive change in temperature will always produce a positive change in frequency.
- ANODE VOLTAGE:** The operating frequency is a function of the anode voltage; therefore, any voltage ripple on the anode supply will appear as frequency modulation on the RF output signal.

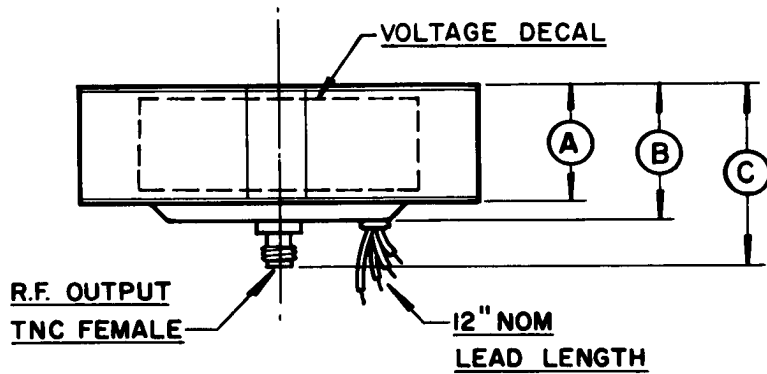

DIMENSIONS IN INCHES			
DIMENSIONAL DATA			
REF.	MIN.	MAX.	NOM.
A			1.375
B			1.562
C			2.312
D		4.515	
E	3.640	3.671	
F		3.031	
G			1.656
H			1.500
J			.375
K			1.062
L			.187 D.

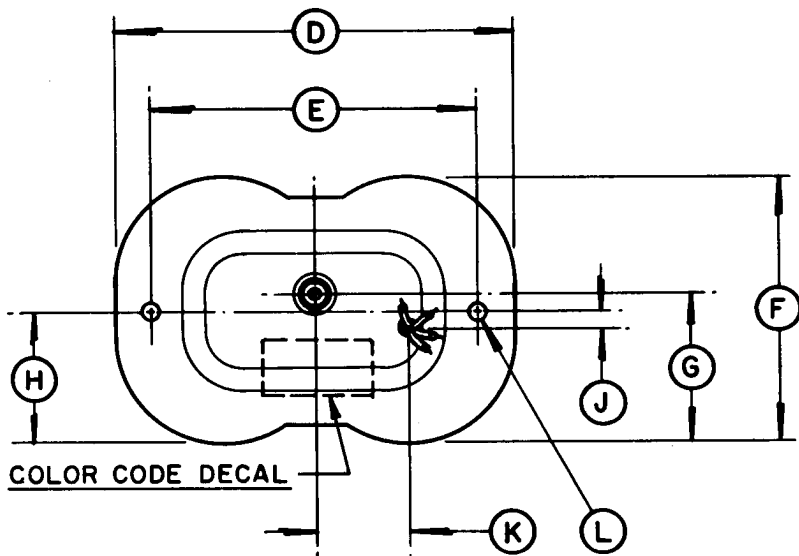

- CONNECTIONS**
- GROUND - GREEN**
 - HEATER - WHITE**
 - HEATER CATHODE - BLACK**
 - INJECTION ANODE - YELLOW**