

—PRODUCT INFORMATION—

Y-1692

Development Type *



**ELECTRONIC
INNOVATIONS
IN ACTION**

MICROWAVE DEVICES

Planar Triode

The Y-1692 is a triode of ceramic-and-metal planar construction intended for use as a CW amplifier or oscillator at frequencies up to 2500 megacycles. The Y-1692 is specifically designed for lower voltage-higher current applications.

CHARACTERISTICS AND TYPICAL OPERATION

AVERAGE CHARACTERISTICS

	Minimum	Bogey	Maximum	Units	Test Conditions				
					Ef V	Eb V	Ib Ma	RL Ohms	Rk Ohms
Heater Voltage, AC or DC ●	6.0	6.3	6.6	Volts					
Heater Current	---	1.25	---	Amperes	6.3	---	---	---	---
Plate Current	---	80	---	Milliamperes	6.3	325	---	---	33
Amplification Factor	---	80	---		6.3	325	---	---	33
Transconductance	---	66000	---	Micromhos	6.3	325	---	---	33
Grid Voltage, Cutoff	---	§	---	Volts	---	---	---	---	---
Direct Interelectrode Capacitances ♦									
Grid to Plate: (g to p)	---	4.25	---	pf					
Input: g to (h+k)	---	10.5	---	pf					
Output: p to (h+k)	---	0.062	---	pf					
Cathode Heating Time	10	---	---	Seconds					

CW AMPLIFIER SERVICE

Frequency	900	Megahertz
DC Plate Voltage	400	Volts
Grid Bias	7.2	Volts
Plate Current	200	Milliamperes
Power Input	3	Watts
Power Output	42	Watts

NOTES

- * Both electrical and mechanical characteristics of development types are subject to change; therefore it is recommended that designers consult their General Electric field representative before designing equipment around developmental types.
- The equipment designer should design the equipment so that heater voltage is centered at the specified bogey value, with heater supply variations restricted to maintain heater voltage within the specified tolerance.
- ♦ Measured at 450 KHz using a grounded adapter that provides shielding between external terminals of tube.
- § To be determined.



Supersedes PI Sheet dated 12-68

ABSOLUTE-MAXIMUM RATINGS

CW OSCILLATOR OR AMPLIFIER SERVICE

Plate Voltage	600	Volts
Plate Dissipation [⊗]	50	Watts
Average Cathode Current	250	Milliamperes
Average Grid Current	50	Milliamperes
Envelope Temperature at Hottest Point [▲]	250	°C
Temperature Differential Between Two Adjacent Electrodes [□]	75	°C
Mechanical Vibration (20-2000 Hz Sinusoidal)	30	G Peak

Absolute-Maximum ratings are limiting values of operating and environmental conditions applicable to any electron device of a specified type as defined by its published data and should not be exceeded under the worst probable conditions.

The device manufacturer chooses these values to provide acceptable serviceability of the device, making no allowance for equipment variations, environmental variations, and the effects of changes in operating conditions due to variations in the characteristics of the device under consideration and

of all other electron devices in the equipment.

The equipment manufacturer should design so that initially and throughout life no absolute-maximum value for the intended service is exceeded with any device under the worst probable operating conditions with respect to supply-voltage variation, equipment component variation, equipment control adjustment, load variation, signal variation, environmental conditions, and variations in the characteristics of the device under consideration and of all other electron devices in the equipment.

NOTES

- ⊗ With adequate heat sink attached to threaded plate stud.
- ▲ For specific recommendations concerning higher temperature operation, contact your General Electric sales representative.
- This assumes no thermal heat sinking to any insulator.

The devices and arrangements disclosed herein may be covered by patents of General Electric Company or others. Neither the disclosure of any information herein nor the sale of devices by General Electric Company conveys any license under patent claims covering combinations of these devices with other devices or elements. In the

absence of an express written agreement to the contrary, General Electric Company assumes no liability for patent infringement arising out of any use of these devices with other devices or elements by any purchaser or others.

PHYSICAL DIMENSIONS

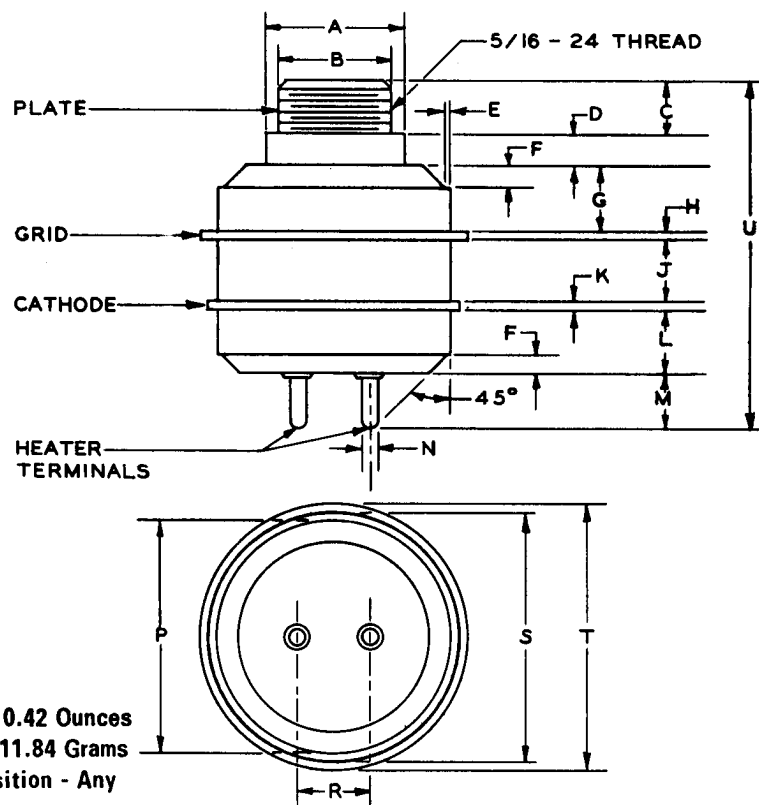

NOTES:

1. Net Weight - 0.42 Ounces
- 11.84 Grams
2. Mounting Position - Any

Ref.	INCHES			MILLIMETERS		
	Min.	Nom.	Max.	Min.	Nom.	Max.
A	0.387	0.390	0.393	9.830	9.906	9.982
B	---	---	0.311	---	---	7.899
C	0.140	0.150	0.160	3.556	3.810	4.064
D	0.098	0.103	0.108	2.489	2.616	2.743
E	---	0.005	---	---	0.127	---
F	0.040	0.050	0.060	1.016	1.270	1.524
G	0.182	0.187	0.192	4.623	4.750	4.877
H	0.025	0.028	0.031	0.635	0.711	0.787
J	0.169	0.174	0.179	4.293	4.420	4.547
K	0.025	0.028	0.031	0.635	0.711	0.787
L	0.170	0.175	0.180	4.318	4.445	4.572
M	0.170	0.175	0.180	4.318	4.445	4.572
N	0.047	0.050	0.053	1.194	1.270	1.346
P	0.635	0.650	0.665	16.13	16.51	16.89
R	0.186	0.200	0.214	4.724	5.080	5.436
S	0.698	0.703	0.708	17.73	17.86	17.98
T	0.748	0.753	0.758	19.00	19.13	19.25
U	0.979	1.020	1.061	24.87	25.91	26.95

Y-1692

Page 4
12-70

TUBE PRODUCTS DEPARTMENT

GENERAL  ELECTRIC

Owensboro, Kentucky 42301