

ELECTRON TUBE DIVISION
P.O. BOX 100
Easton, Pennsylvania 18042
Telephone 215 252-7331

F-2131

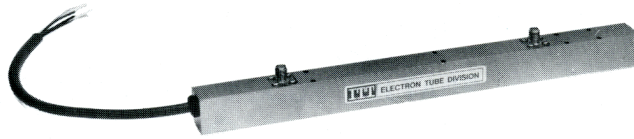

TRAVELING WAVE TUBE

DESCRIPTION

The tube type 2131 is a miniature, lightweight, 25 watt CW traveling wave tube amplifier covering the frequency range of 7.0 to 17 GHz with 50 dB small signal gain. The tube uses a helix type slow wave structure and is PPM focused with samarium cobalt magnets. It is of metal-ceramic construction for rugged environmental applications. The tube is conduction cooled and may be mounted in any position. The collector is isolated and may be depressed up to 50% of the cathode voltage. Type SMA coaxial fittings are provided for RF input and output. An anode electrode is provided that may be used for gain, current control and ion trapping.

RF PERFORMANCE

	Typical Values	Performance Limits
Frequency	7.0-17.0 GHz	7.0-17.0 GHz
Output Power	30 Watts	20 Watts Min.
Power Gain	57 dB	45 dB Min.
Noise Figure	30 dB	32 dB Max.
Duty Cycle.....	CW	CW

ELECTRICAL REQUIREMENTS

	Typical Values	Performance Limits		
		Min.	Max.	Units
Cathode Voltage	-3900	-3600	-4000	Volts
Cathode Current	95	—	130	mA
Anode Voltage	180	-4000	500	Volts
Heater Voltage	6.3	6.0	6.6	Volts
Heater Current7	—	.8	Amp
Helix Current	5	—	12	mA
Collector Voltage	-1950	—	-2000	Volts

MECHANICAL

RF Connections	SMA Female
DC Connections	Flying Leads
Cooling (NOTE 1)	Conduction
Weight75 Pounds
Mounting Position	Any
Construction	Metal-Ceramic
Focusing	PPM

ENVIRONMENTAL

Shock	40G, 11 millisecond
Vibration	30G, 5-2000 cycles
Temperature	-45 to +85° C

NOTE 1: For proper conduction cooling the tube must be securely fastened to a flat heat sink surface. The use of heat sink compound (astrodyne 829 or equivalent) is recommended.

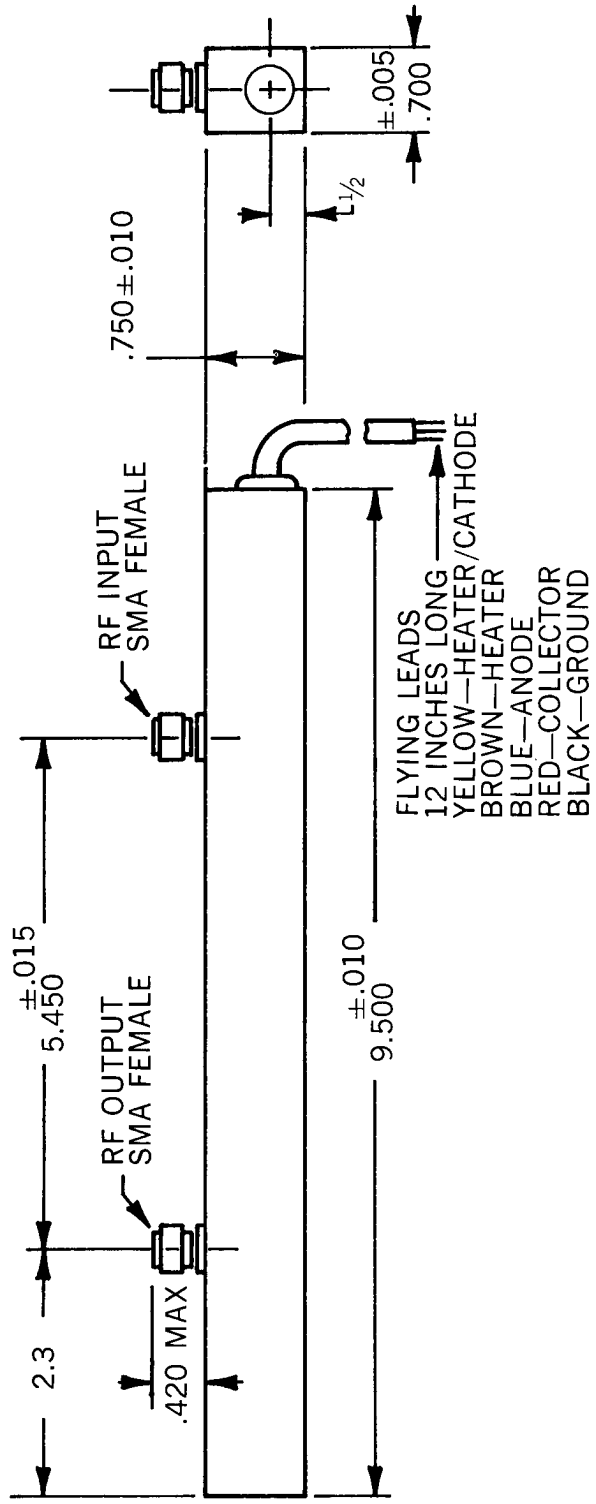
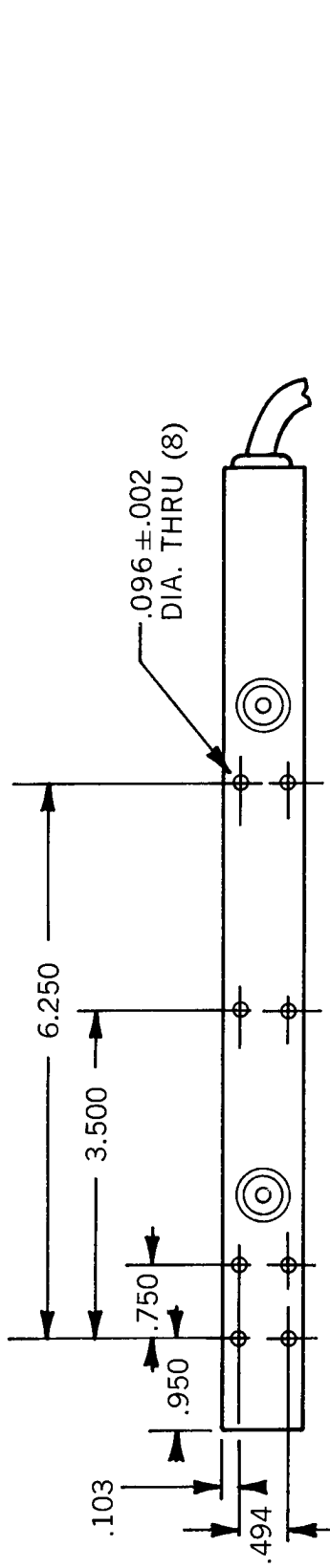

F-2131 OUTLINE

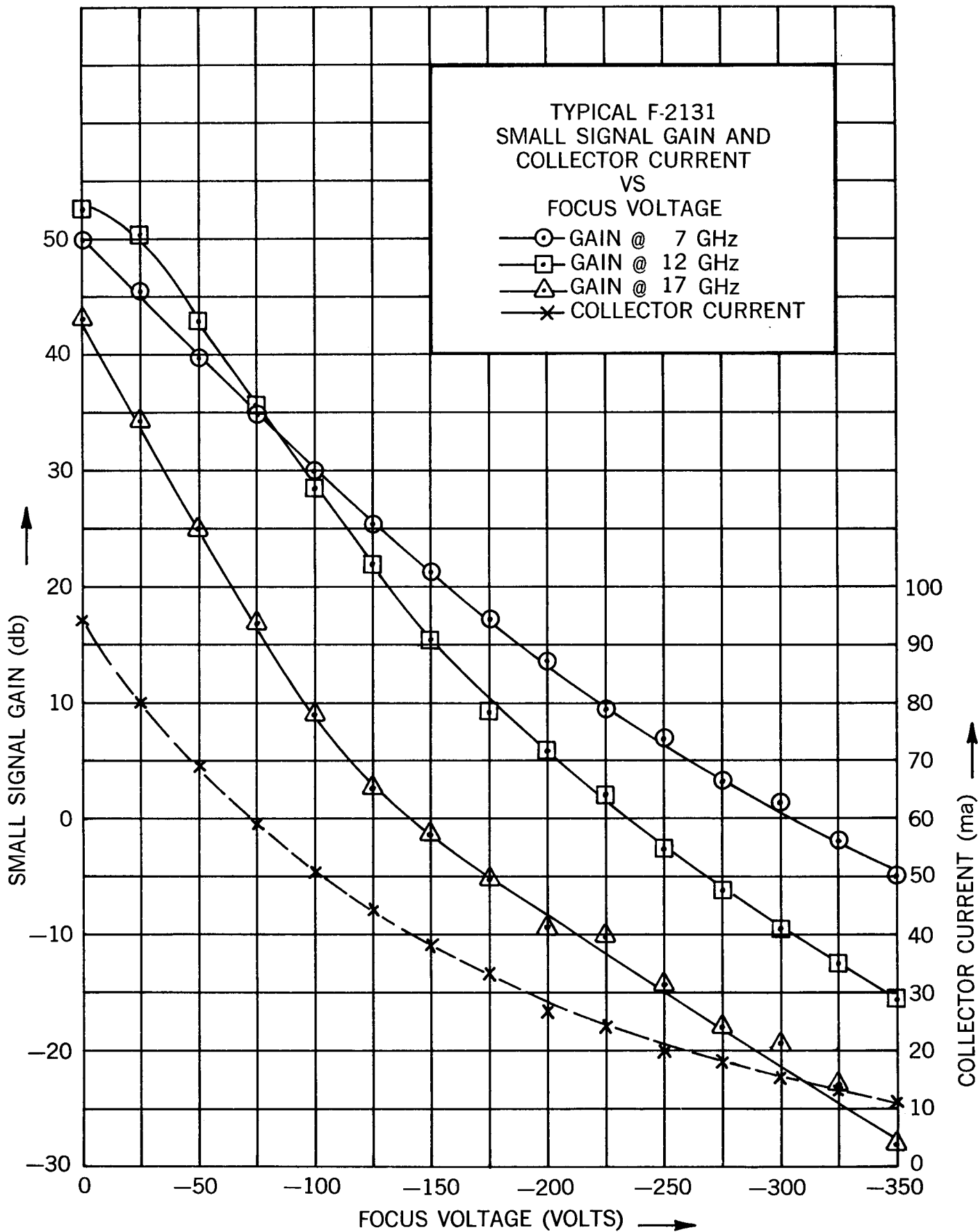

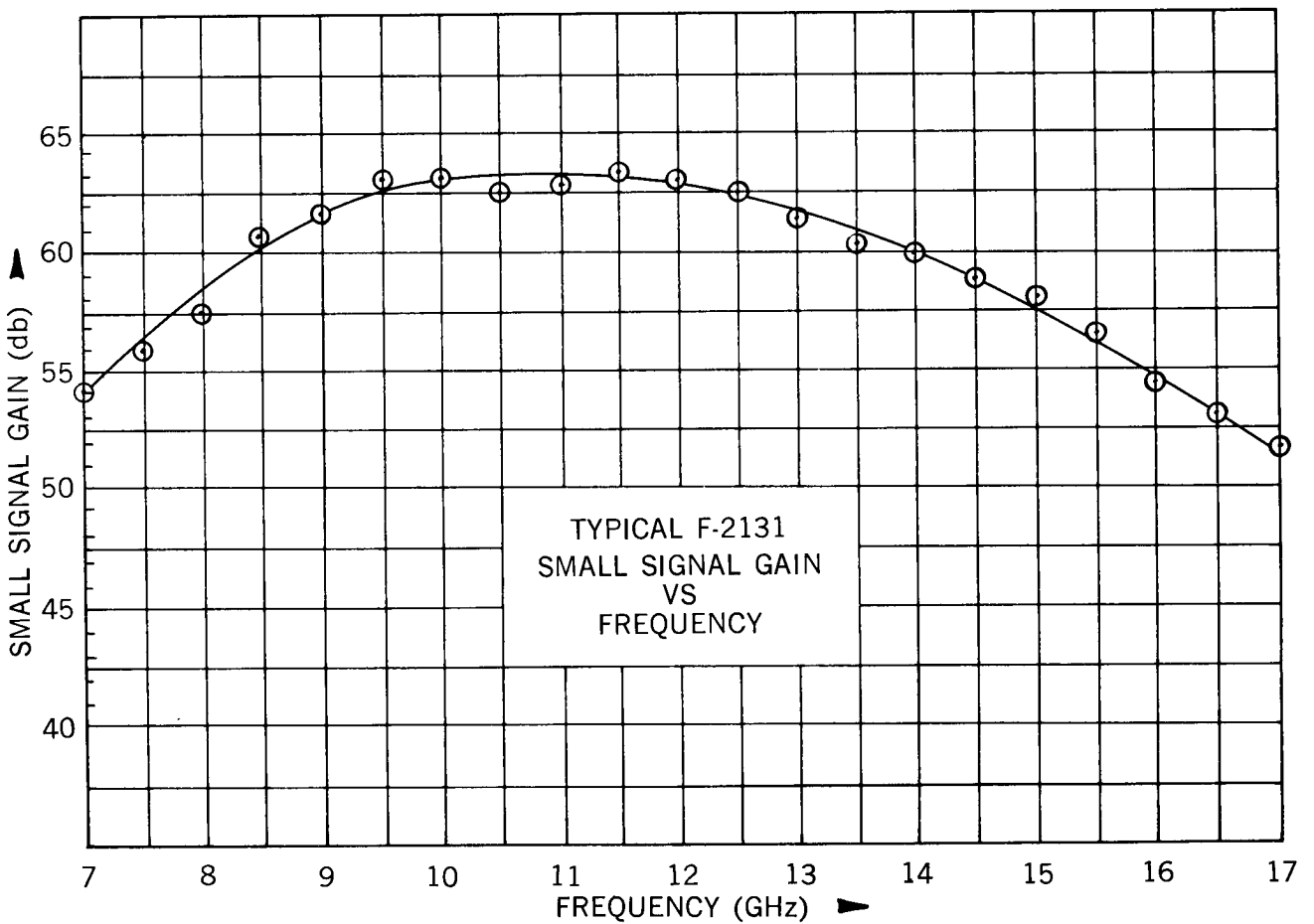
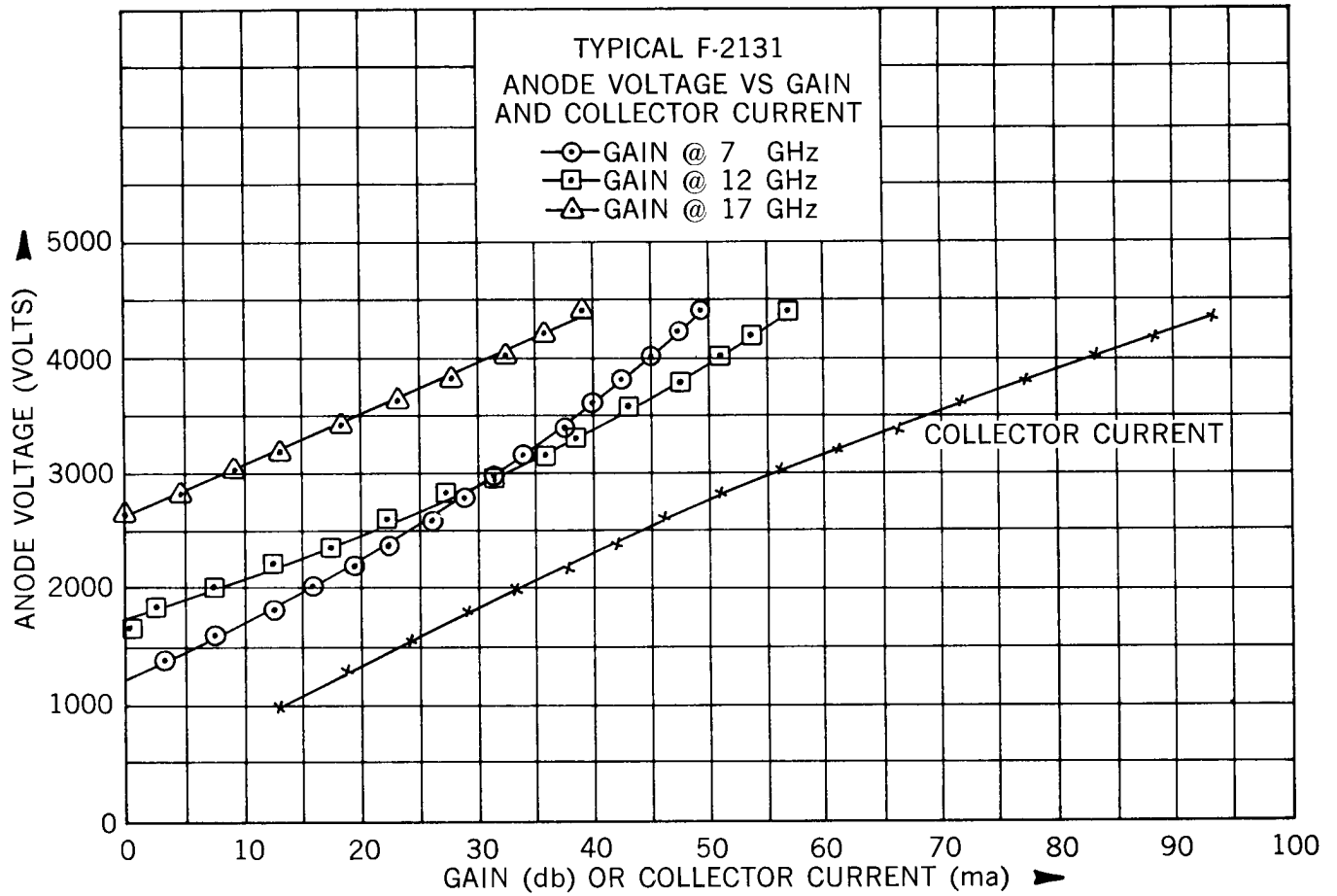

F-2131

