

Burroughs Corporation

ELECTRONIC COMPONENTS DIVISION
PLAINFIELD, NEW JERSEY

Bulletin No. 1027

NUMERICAL INDICATOR
Engineering Data Report

January 1, 1963

8422

(B5991) Ultra Long Life Rectangular NIXIE^R Tube

The 8422 (B5991) is a gas-filled, cold-cathode, rectangular numerical indicating tube containing a common anode and ten metallic cathodes. The cathodes are formed in the shape of numerals ("0" through "9"). The tube is intended for use as a direct in-line readout device. The width and depth of this tube are approximately 75% of standard size cylindrical types permitting side by side stacking in a minimum of panel space with no sacrifice in readability.

MECHANICAL DATA

Overall Length	1.120 Max.
Seated Height862 Max.
Bulb Width790 Max.
Bulb Length	1.020 Max.
Numeral Height610 Nominal
Pin Connection	See figure 3
Mounting Position	See note 2
Weight3 oz. nom.

ELECTRICAL DATA

Absolute Ratings

Ionization Voltage	170 Vdc Max.
Supply Voltage	170 Vdc Min. (Note 1)
Cathode Current	3.5 ma max.

Test Conditions (See Figure 1)

Supply Voltage (E)	170 Vdc
Series Resistor (R)	8.2 K
Cathode Current (Minimum)	1.5 ma
(Maximum)	3.0 ma

ENVIRONMENTAL DATA

Temperature	-65° C. to +70° C. (Note 1)
Altitude	70,000 feet

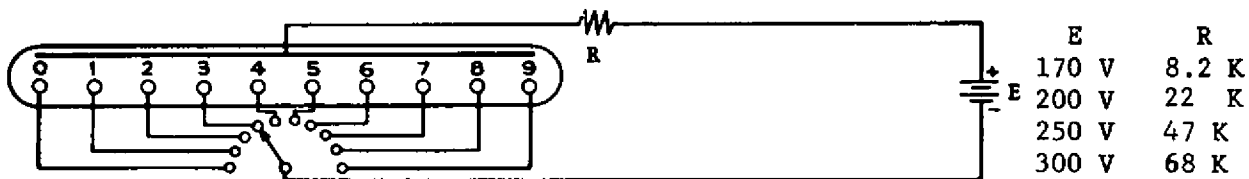

FIGURE 1. Basic Circuit

NOTES

1. The minimum supply voltage should be 170 volts. However, the use of highest available voltage with the appropriate series resistor is recommended to maintain cathode current within the specified limits. A supply voltage of 200 volts or more is recommended to assure proper operation at the temperature extremes.
2. The center line of the numbers to be displayed passes through pins 6 and 12 of the tube. The tube socket should be oriented so that pins 6 and 12 are in a vertical line with pin 12 at the top.

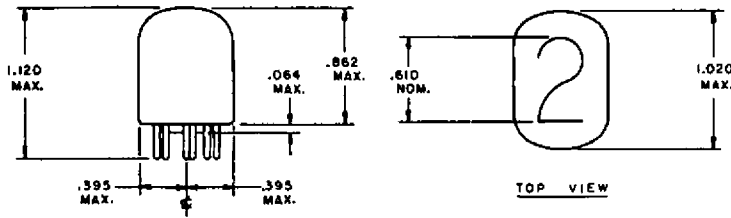

Figure 2. OUTLINE DRAWING

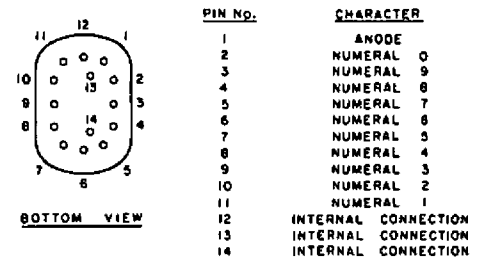

Figure 3. PIN CONNECTIONS

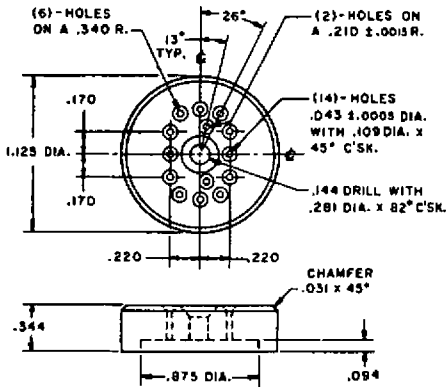

Figure 4. PIN STRAIGHTENER, LS-210

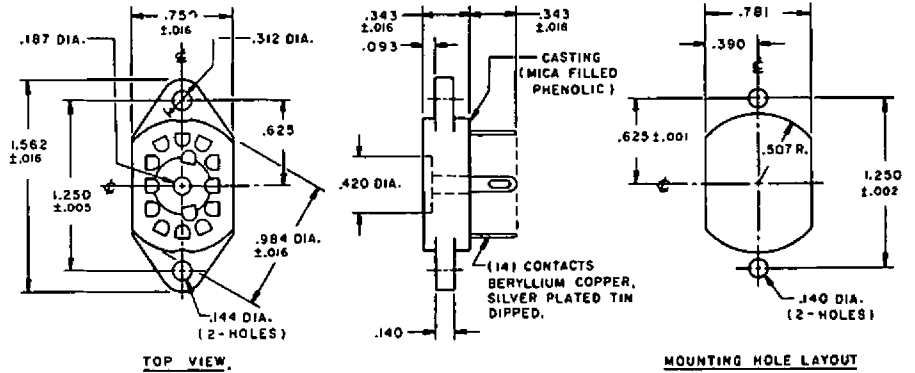

Figure 5. GENERAL PURPOSE SOCKET, SK-136

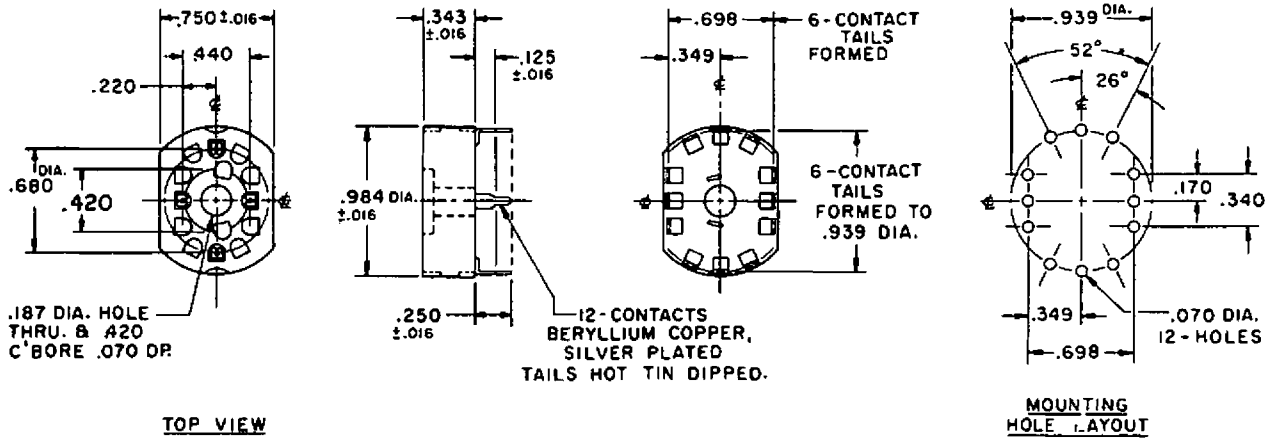

Figure 6. PRINTED CIRCUIT SOCKET, SK-144

ANOTHER ELECTRONIC CONTRIBUTION BY
Burroughs Corporation
 ELECTRONIC COMPONENTS DIVISION
 PLAINFIELD, NEW JERSEY