

Ordering code Q52-X2058

Coaxial metal-ceramic tetrode, water-cooled with integrated cooling jacket, particularly suitable for RF amplifiers up to 220 MHz.

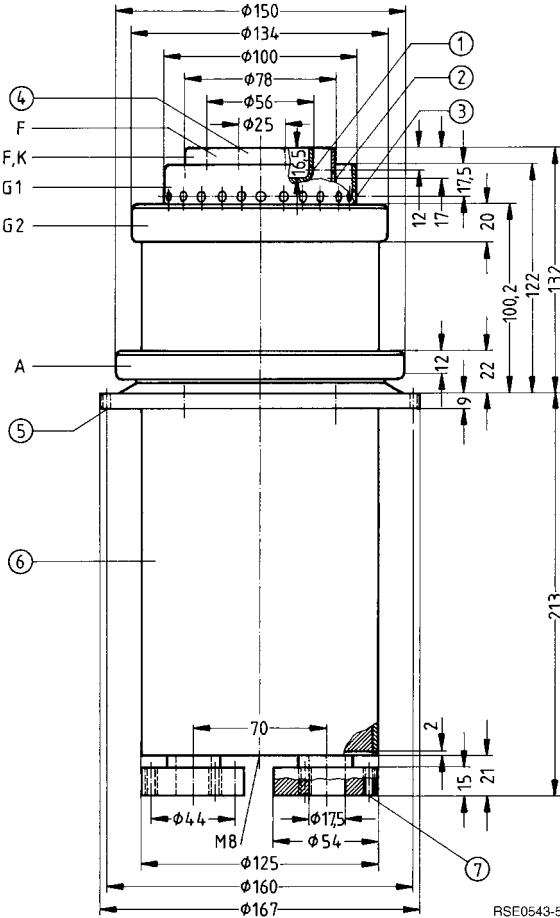

RSE0543-5

Dimensions in mm

- ① 24 ventilation holes 3 mm dia. ($24 \times 15^\circ$)
- ② 24 ventilation holes 4 mm dia. ($24 \times 15^\circ$)
- ③ 24 ventilation holes 5 mm dia. ($24 \times 15^\circ$)
- ④ Do not use as terminal
- ⑤ 6 fixing holes 4.5 mm dia. ($6 \times 60^\circ$)
- ⑥ Do not use cooling jacket as anode terminal
- ⑦ 3 tapholes M6 ($3 \times 120^\circ$)

Approx. weight 11,5 kg

Heating

Heater voltage	U_F	11	V
Heater current	I_F	≈ 185	A
Heating: direct			
Cathode: thoriated tungsten			

Characteristics

Emission current at $U_A = U_{G2} = U_{G1} = 550\text{ V}$	I_{em}	100	A
Amplification factor of screen grid at $U_A = 3\text{ kV}$, $U_{G2} = 800\text{ to }1200\text{ V}$, $I_A = 5\text{ A}$	μ_{g2g1}	6,0	
Transconductance at $U_A = 3\text{ kV}$, $U_{G2} = 1200\text{ V}$, $I_A = 3\text{ A}$	s	75	mA/V

Capacitances

Cathode/control grid	C_{kg1}	≈ 140	pF
Cathode/screen grid	C_{kg2}	≈ 11	pF
Cathode/anode	C_{ka}	≈ 0,3	pF 1)
Control grid/screen grid	C_{g1g2}	≈ 180	pF
Control grid/anode	C_{g1a}	≈ 1,8	pF 1)
Screen grid/anode	C_{g2a}	≈ 40	pF

Accessories

Upon request

1) Measured by means of a 40 cm diameter screening plate in the screen grid terminal plane.

**RF amplifier,
class B operation, grounded control-grid screen-grid circuit**

Maximum ratings

Frequency	f	220	MHz
Anode voltage (dc)	U_A	12	kV
Screen grid voltage (dc)	U_{G2}	1000	V
Control grid voltage (dc)	U_{G1}	- 350	V
Cathode current (dc)	I_K	35	A
Peak cathode current	I_{KM}	100	A
Anode dissipation	P_A	90	kW
Screen grid dissipation	P_{G2}	650	W
Control grid dissipation	P_{G1}	160	W

Operating characteristics

Frequency	f	200	MHz
Output power	P_2	64 + 2,3 ²⁾	kW ¹⁾
Anode voltage (dc)	U_A	10	kV
Screen grid voltage (dc)	U_{G2}	900	V
Control grid voltage (dc)	U_{G1}	- 250	V
Peak control grid voltage (ac)	$U_{g1 m}$	320	V
Anode current (dc)	I_A	8,8	A
Screen grid current (dc)	I_{G2}	0,25	A
Control grid current (dc)	I_{G1}	0,3	A
Anode input power	$P_{B A}$	88	kW
Drive power	P_1	90 + 2300 ²⁾	W ¹⁾
Anode dissipation	P_A	22	kW
Screen grid dissipation	P_{G2}	225	W
Control grid dissipation	P_{G1}	15	W
Efficiency	η	72	%
Anode load resistance	R_A	550	Ω

1) Circuit losses are not included.

2) Power transition of grounded control-grid screen-grid circuit.

**RF amplifier,
class B operation, grounded control-grid screen-grid circuit**

Maximum ratings

Frequency	f	220	220	MHz
Anode voltage (dc)	U_A	15	12	kV
Screen grid voltage (dc)	U_{G2}	1500	1000	V
Control grid voltage (dc)	U_{G1}	- 350	- 350	V
Cathode current (dc)	I_K	35	35	A
Peak cathode current	I_{KM}	100	100	A
Anode dissipation	P_A	90	90	kW
Screen grid dissipation	P_{G2}	400	650	W ⁵⁾
Control grid dissipation	P_{G1}	160	160	W

Operating characteristics

Frequency	f	200	200	MHz
Pulse duration	t_p	$0,25 \times 10^{-3}$	1,0	s
Pulse separation	t_0	1,0	3,0	s
Pulse output power	P_{2p}	$150 + 4,6^2)$	$116 + 4^2)$	kW ¹⁾
Anode voltage (dc)	U_A	13,5	10	kV
Screen grid voltage (dc)	U_{G2}	1100	900	V
Control grid voltage (dc)	U_{G1}	- 250 ³⁾	- 200 ⁴⁾	V
Peak pulse control grid voltage (ac)	U_{g1mp}	370	325	V
Pulse anode current (dc)	I_{Ap}	17,6	19	A
Pulse screen grid current (dc)	I_{G2p}	1	0,6	A
Pulse control grid current (dc)	I_{G1p}	1,5	0,9	A
Pulse anode input power	P_{BAp}	238	190	kW
Pulse drive power	P_{1p}	$0,5 + 4,6^2)$	$0,3 + 4^2)$	kW ¹⁾
Pulse anode dissipation	P_{Ap}	88	74	kW
Mean anode dissipation	P_A	0,02	19	kW
Pulse screen grid dissipation	P_{G2p}	1400	700	W
Pulse control grid dissipation	P_{G1p}	140	90	W
Pulse efficiency	η	63	61	%
Anode load resistance	R_A	480	335	Ω

- 1) Circuit losses are not included.
- 2) Power transition of grounded control-grid screen-grid circuit.
- 3) For zero signal dc anode current $I_{A0} = 1$ A.
- 4) For zero signal dc anode current $I_{A0} = 0,5$ A.
- 5) Mean value, permissible at the pulse frequency stated in the corresponding column.

Tube mounting

Axis vertical, anode up or down.

For connection of the tube use either header connectors or individual connectors (upon request).

Maximum tube surface temperature

The temperature of the metal-ceramic seals must not exceed 220 °C at any point. If the header sockets with air connecting piece intended for RF operation are used, sufficient cooling is ensured by a minimum air flow of 0,6 m³/min with a pressure drop of approximately 1,5 mbar. If individual connectors are used, a free air stream of 2 m³/min has to be directed onto the terminal side.

Water cooling

The cooling water diagram is valid for 35 °C water inlet temperature. The maximum permissible pressure of the cooling water, measured at the water inlet, is 6 bar. Please observe instructions on water cooling given under "Explanations on Technical Data".

Safety precautions

The section "Safety precautions" under "Explanations on Technical Data" describes how the tube is to be protected against damage due to electric overload or insufficient cooling. A copper wire with 0,25 mm diameter should be used to test the anode overcurrent trip circuit.

Cooling water diagram

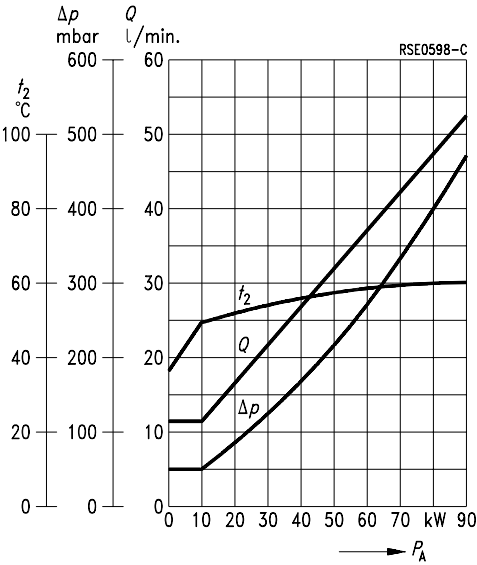

$t_1 = 35\text{ °C}$

Tuning curves for coaxial circuits

Control-grid cathode circuit

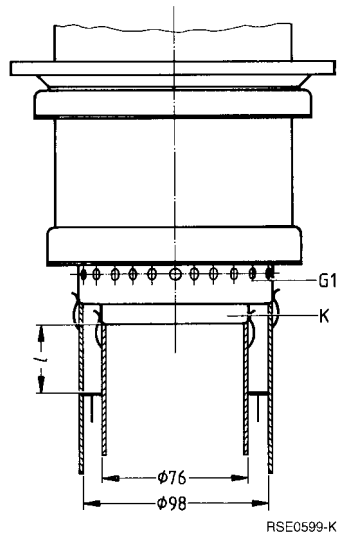
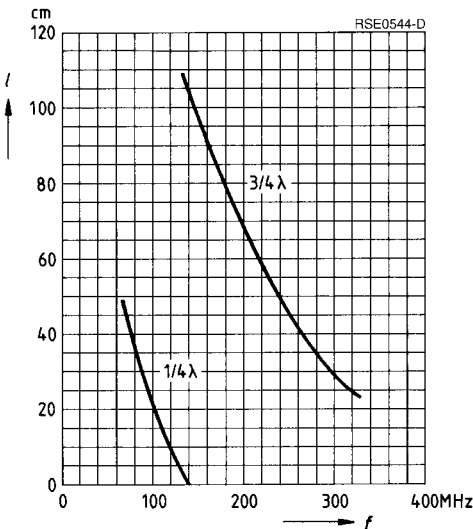

Tuning curves for coaxial circuits

Screen-grid control-grid circuit

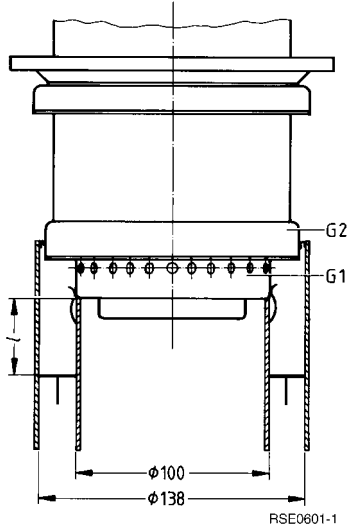
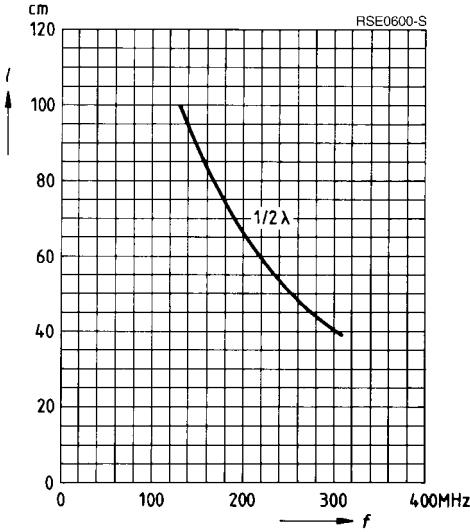

Tuning curves for coaxial circuits

Anode screen-grid circuit

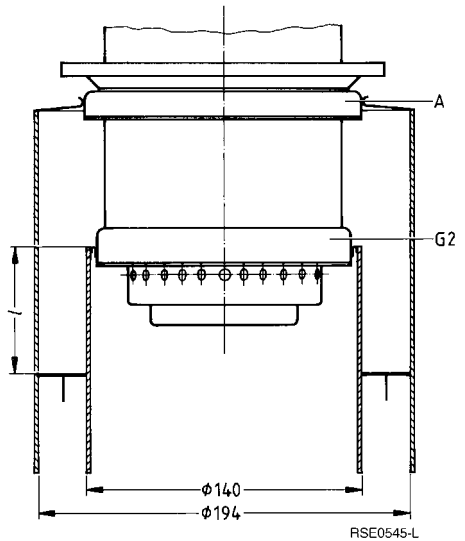
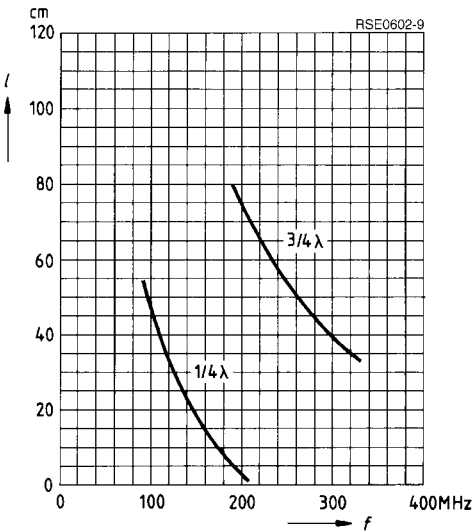

$U_{G1} = f(U_A)$
 $U_{G2} = 700 \text{ V}$
 Parameter = I_A _____
 Parameter = I_{G2}
 Parameter = I_{G1} - - - - -

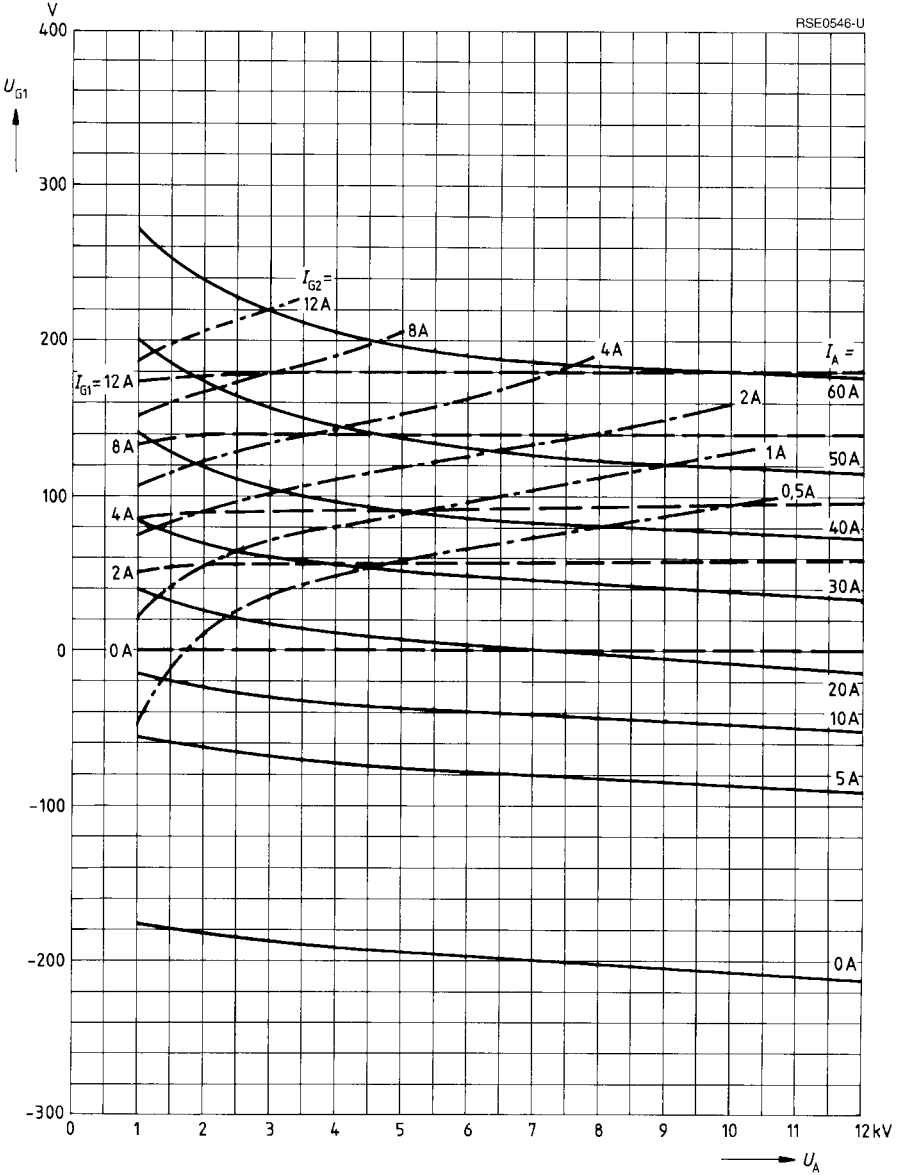

$U_{G1} = f(U_A)$
 $U_{G2} = 900 \text{ V}$

Parameter = I_A —————
Parameter = I_{G2} - - - - -
Parameter = I_{G1} - · - · - · - · - · - · - · - ·

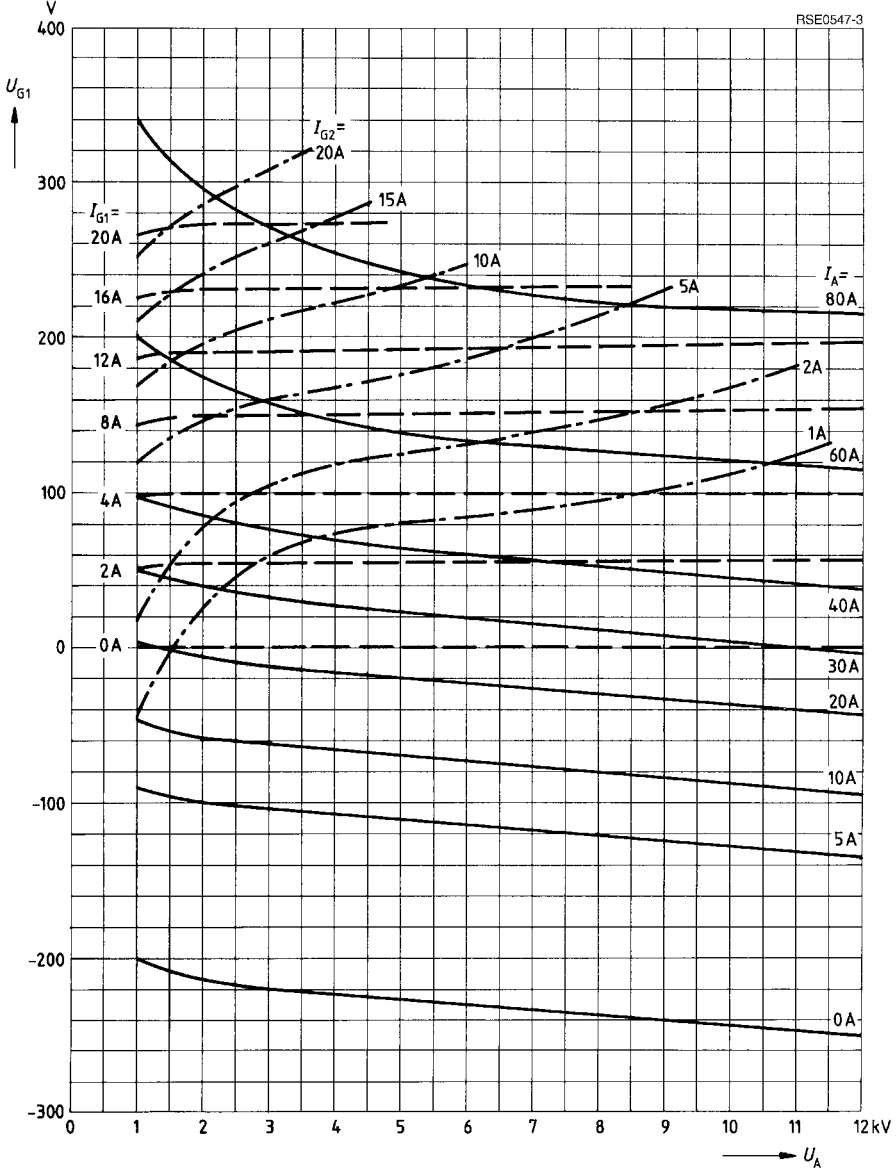

$U_{G1} = f(U_A)$
 $U_{G2} = 1100 \text{ V}$
 Parameter = I_A _____
 Parameter = I_{G2} - - - - -
 Parameter = I_{G1} - - - - -

